

# DIGITAL SOLUTIONS PRODUCT REFERENCES

CATALOGUE

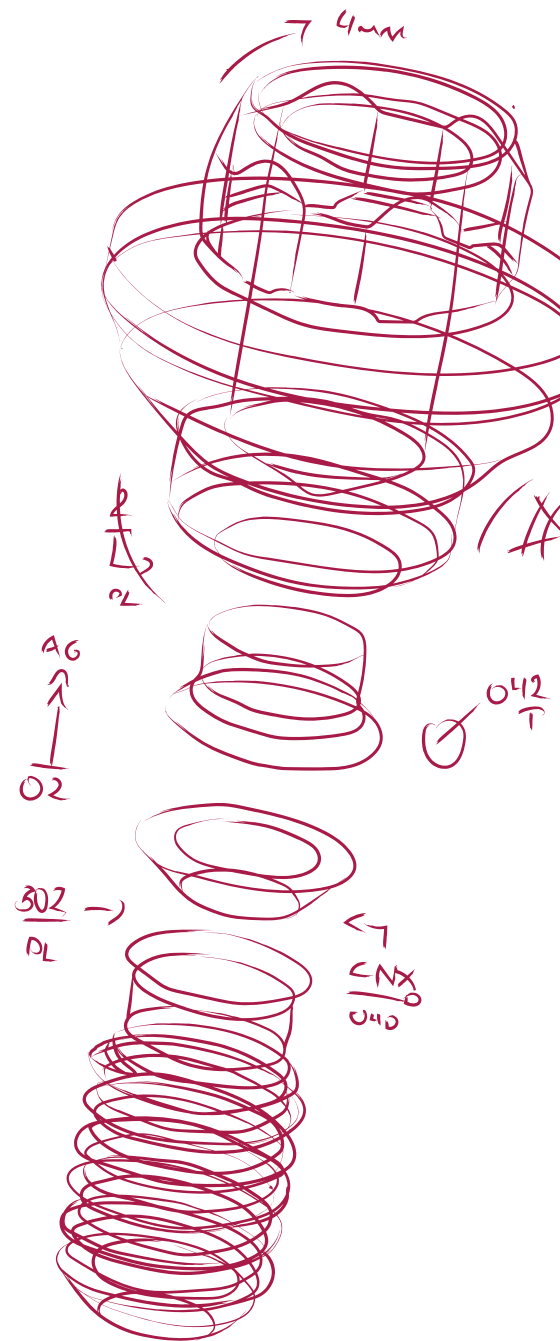

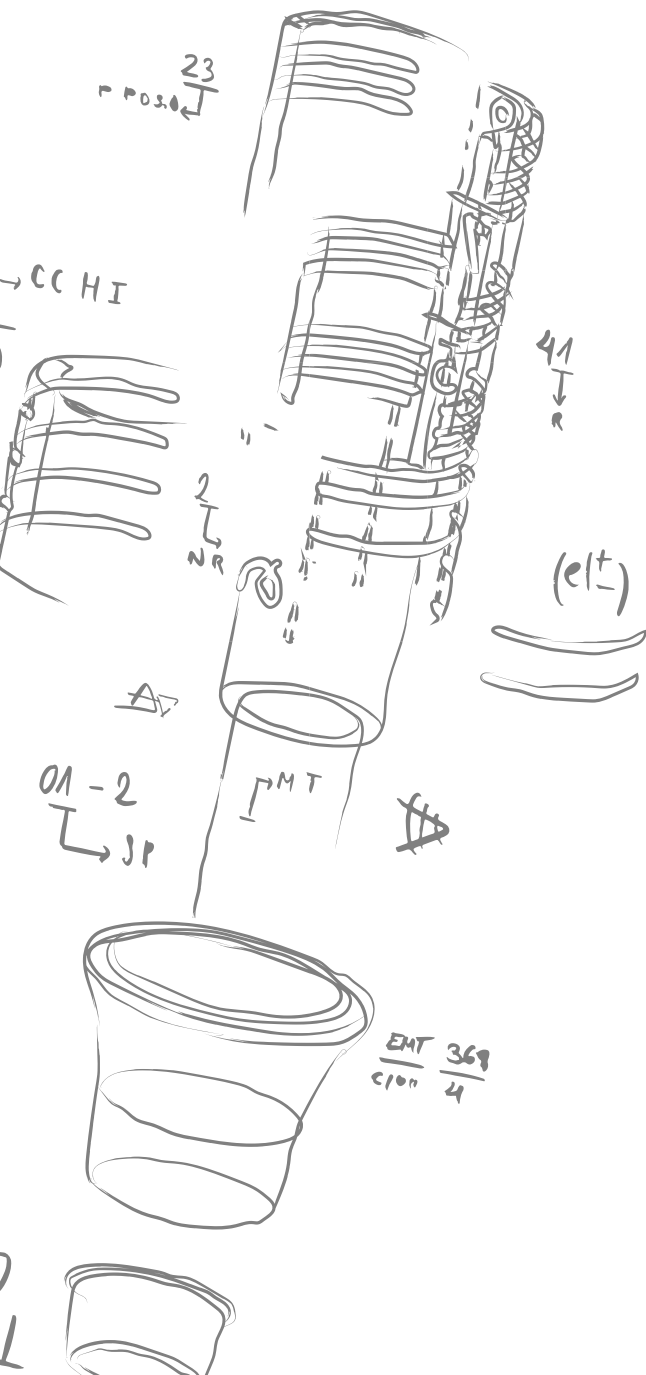

## DYNAMIC ABUTMENT SOLUTIONS

---

Virginia Woolf, 17  
25005 · Lleida (Spain)

INTERNATIONAL +34 873 450 709  
das@dynamicabutment.com

SPAIN +34 973 289 580  
spain@dynamicabutment.com



Dynamic Abutment Solutions is the trademark of the manufacturer Talladium España S.L. The information included in this catalogue is exclusively addressed to professionals in dental sector.

All commercial trademarks mentioned herein are fully registered by their respective companies, and the images that appear are just to provide an orientation. Talladium reserves the right to modify this document without previous notice. Talladium is not responsible for the inadequate execution of these products if the warning indications corresponding to every reference are not contemplated.

Ask about the products available with CE legislation. Some of the products are not authorized for sale and distribution or do not have a sales license in some countries according to other legislations. Information: [das@dynamicabutment.com](mailto:das@dynamicabutment.com).

# INDEX

<b>LIST OF COMPATIBILITIES AVAILABLE</b>	<b>5</b>
<b>COMPATIBILITIES AVAILABLE</b>	<b>9</b>
<b>COMPATIBILITIES AND REFERENCES</b>	<b>43</b>
<b>DAS LIBRARIES</b>	<b>330</b>
<b>MULTI-UNIT DAS LIBRARIES</b>	<b>331</b>
<b>DYNAMIC SCREWS TECHNICAL SPECIFICATIONS</b>	<b>332</b>
<b>STRAIGHT SCREWS TECHNICAL SPECIFICATIONS</b>	<b>334</b>
<b>SCREWDRIVERS AND STRAIGHT SCREWS</b>	<b>335</b>
<b>DYNAMIC MILLING TOOL SPECIFICATIONS</b>	<b>336</b>
<b>SCREWDRIVERS AND COMPLEMENTS</b>	<b>338</b>
<b>DAS MU SYSTEM COMPONENTS</b>	<b>339</b>



## LIST OF COMPATIBILITIES AVAILABLE

AB	CONEXÃO SISTEMA DE PRÓTESE	HAHN IMPLANT (GLIDEWELL)	NEOBIOTECH	SIN IMPLANTS
ACE			NEODENT	
ADIN	CORTEX	HIOSSSEN	NEOSS	SOUTHERN IMPLANTS
ALFA-GATE	C-TECH	HI-TEC		
ALPHABIO	COWELLMEDI	IBS	NOBEL BIOCARE	STERI-OSS
ALPHA-DENT	DENTAL TECH	IDO IMPLANTS	NORIS MEDICAL	STERNGOLD
ANCLADEN	DENTAURUM	IHDE DENTAL (IMBIODENT)	NORMON	STRAUMANN
ANKYLOS	DENTEGRIS	IMPLANT DIRECT	NOVA IMPLANTS	SURCAM DENTAL
ANTHOGYR	DENTEM			SYBRON IMPLANT SOLUTIONS
ARDS	DENTIS	IMPLANT GENESIS	OSSTEM IMPLANT	SYSTHEX
ASTRA	DENTIUM	IMPLANTSWISS	OSTEOPLUS	TBR
AVINENT	DIO IMPLANTS	INTRA-LOCK	OXY	TITANIUM-FIX
B&W		JDENTALCARE	PALTOP	TREE-OSS
BEGO	DITRON	KEYSTONE	P-I BRANEMARK	TRI DENTAL IMPLANTS
BIOCONCEPT	DMI DENTAL SUPPLY	KLOCKNER	PHIBO	TRINON
BIOGENESIS	DSP BIOMEDICAL	KUWOTECH	POINT IMPLANT	UFIT
BIOHORIZONS	EASY IMPLANT	LASAK		
BIOMET 3i	ECKERMANN	LEADER	PROCLINIC	VULKAN IMPLANTS
BIOLOK	ELITE MEDICA	MEDENTIKA	PROTEG IMPLANTS	WARANTEC (ONEPLANT)
BIONER	EUROTEKNIKA	MEDENTIS	RADHEX	WIN
BIOTEC		MEGAGEN	REFLECT	XIVE
BIOTEM	F&B IMPLANT (FIT & BRILLIANT)	MICRODENT	RITTER	YES IMPLANT
BREDDENT MEDICAL	GALIMPLANT	MIS	ROOTT	YOUSE IMPLANTS
BTI	GC TECH	MONOIMPLANT	SEWON MEDIX	ZIACOM
BTK	GMI (ILERIMPLANT)	MOZO-GRAU (TICARE)	SIC INVENT	ZIMMER
CAMLOG	GT MEDICAL	MPI	SIGNO VINCES	

**MULTI-UNIT**  
DAS SYSTEM

**DYNAMIC**  
DAS SYSTEM

## COMPATIBILITIES AVAILABLE



AB	MODEL	IMPLANT	PLATFORM	CODE	
	I2	3,5/3,75/4,2/4,5/ 5/6	STANDARD STANDARD	0040 0040	129 129
	I22	3,75/4,22	STANDARD	0040	129
	I5	3,5/3,75/4,2/4,5/ 5/6/7/8	STANDARD STANDARD	0040 0040	129 129
	I55	3,75/4,2/4,5 5/6/7/8	STANDARD STANDARD	0040 0040	129 129
	I10	4,2/5	STANDARD	0040	129
	I15	06/07/2008	STANDARD	0040	129
	MULTI UNIT D1-P64	Multi Unit D1-P64	UNIVERSAL	0025	101

ACE	MODEL	IMPLANT	PLATFORM	CODE	
	EXTERNAL HEX	3,3	NP 3,5	0023	97
		3,75/4	RP 4,1	0024	99
		4,75	WP 5	0058	161
	INFINITY TRI-CAM	3,5	3,5	0026	104
		4,3	4,3	0027	106
		5	5	0028	108
	INFINITY INTERNAL HEX	3,7/4,1	3,5	0040	129
		4,7/5,1	4,5	0041	134
		3,3	RP 4,8	0037	122
	INFINITY OCTAGON	4,1	RP 4,8	0037	122
		4,8	RP 4,8	0037	122
		4,8	WP 6,5	0096	199
	MULTI UNIT	Universal	UNIVERSAL	0025	101

ADIN	MODEL	IMPLANT	PLATFORM	CODE	
	SWELL	3,3	3,45	0040	129
		3,3	3,45	0042	129
		3,75/4,2	3,6	0040	129

## COMPATIBILITIES AVAILABLE



ADIN	MODEL	IMPLANT	PLATFORM	CODE		
	SWELL	3.75/4.2	3.6	0042	129	
		5	4	0040	129	
		5	4	0042	129	
		6	4.6	0040	129	
		6	4.6	0042	129	
	TOUAREG-S / TOUAREG-OS	3.5	3.45	0040	129	
		3.5	3.45	0042	129	
		3.75/4.2	3.6	0040	129	
		3.75/4.2	3.6	0042	129	
		5	4	0040	129	
		5	4	0042	129	
		6	5	0040	129	
		6	5	0042	129	
	TOUAREG CLOSEFIT	2.75	UNP	0188	277	
		3	NP	0145	237	
		3.5	RP	0021	91	
		4.3/5	WP	0022	94	
	TRIPLE	3.5/3.75/4.2/5/6	STANDARD	0040	129	
		3.5/3.75/4.2/5/6	STANDARD	0042	129	
	MULTI UNIT TMA	Universal	UNIVERSAL	0025	101	
	ALFA-GATE	BIOACTIVE/POROUS/ TRIO/MAX	3.3/3.75/4.2/ 4.7/5.2/6	SP	0040	129
			3.5	NP	0021	91
		CONICAL	4.3/5	RP	0022	94
ALPHABIO	INTERNAL HEX CONNECTION (IH) SPI	3.3/3.75/4.2/5/6	UNIVERSAL	0040	129	
		INTERNAL HEX CONNECTION (IH) ICE	3.7/3.75/4.2/ 4.65/5.3	UNIVERSAL	0040	129

## COMPATIBILITIES AVAILABLE



ALPHABIO	MODEL	IMPLANT	PLATFORM	CODE	
	INTERNAL HEX CONNECTION (IH) DFI	3.3/3.75/4.2/5	UNIVERSAL	<b>0040</b>	129
	INTERNAL HEX CONNECTION (IH) ATID	3.3/3.75/4.2/5/6	UNIVERSAL	<b>0040</b>	129
	INTERNAL HEX CONNECTION (IH) NEO	3.75/4.2/5	3.5	<b>0040</b>	129
	CONICAL HEX CONNECTION (CHC) NICE	3.2	NARROW	<b>0136</b>	234
	CONICAL HEX CONNECTION (CHC) NEO	3.2/3.5	NARROW	<b>0136</b>	234
	CONICAL STANDARD CONNECTION (CS)	3.75/4.2/5	STANDARD	<b>0169</b>	258
	MULTI UNIT ABUTMENT	-	UNIVERSAL	<b>0195</b>	283

ALPHA-DENT	MODEL	IMPLANT	PLATFORM	CODE	
	CLASSIC CONUS	3.3/3.75	3	<b>0265</b>	325
	ACTIVE CONUS	3.25/3.75	3	<b>0265</b>	325

ANCLADEN	MODEL	IMPLANT	PLATFORM	CODE	
	ANCLALOCK	3.3/3.75	3	<b>0265</b>	325
		3.25/3.75	3	<b>0265</b>	325

ANKLYOS	MODEL	IMPLANT	PLATFORM	CODE	
	ANKYLOS	3.5	3.5	<b>0075</b>	172
		4.5	4.5	<b>0075</b>	172
		5.5	5.5	<b>0075</b>	172
		7	7	<b>0075</b>	172
	BALANCE BASE NARROW	Universal	UNIVERSAL	<b>0183</b>	270

## COMPATIBILITIES AVAILABLE



ANTHOGYR	MODEL	IMPLANT	PLATFORM	CODE	
	AXIOM BL REG / PX	3,4	3,4	<b>0161</b>	248
		4	4	<b>0149</b>	238
		4,6	4,6	<b>0149</b>	238
		5,2	5,2	<b>0162</b>	250
	ANTHOFIT HE	3,5/3,75/4	R (4,1)	<b>0024</b>	99
		5	L (5)	<b>0058</b>	161
	OSSFIT	3,5/4,2	4,8	<b>0074</b>	170
		3,5/4,2	4,8	<b>0037</b>	122
		5	6,5	<b>0096</b>	199
	MULTI UNIT	4,8	UNIVERSAL	<b>0163</b>	252

ARDS	MODEL	IMPLANT	PLATFORM	CODE	
	SMART	3,75/4,2/4,5	3,75	<b>0040</b>	129
	CLASSIC	3,3/3,75/4,2/5/6	3,75	<b>0040</b>	129
	PREMIUM	3,3/3,75/4,2/5/6	3,75	<b>0040</b>	129
	CIT	3,3/3,75/4,2/5/6	3,75	<b>0040</b>	129

ASTRA	MODEL	IMPLANT	PLATFORM	CODE	
	YELLOW	3	YELLOW (X-ESTRECHA)	<b>0109</b>	206
	AQUA	3,5/4	AQUA(ESTRECHA)	<b>0004</b>	51
	LILAC	4,5/5	LILAC (ANCHA)	<b>0005</b>	54
	UNIABUTMENT CONO 20O	Regular/Wide	REGULAR/WIDE	<b>0066</b>	169
	UNIABUTMENT CONO 45O	Regular/Wide	REGULAR/WIDE	<b>0067</b>	
	EVOLUTION/ PRIMETAPER	3	3,0	<b>0090</b>	192
		3,6	3,6	<b>0006</b>	56
		4,2	4,2	<b>0007</b>	59
		4,8	4,8	<b>0091</b>	194
		5,4	5,4	<b>0092</b>	197

## COMPATIBILITIES AVAILABLE



ASTRA	MODEL	IMPLANT	PLATFORM	CODE	
	DS OMNITAPER EV	3	XS	0090	192
		3.4	S	0006	56
		3.8	M	0007	59
	MULTIBASE ABUTMENT (SMARTFIX CONCEPT)	4.5	L	0091	194
		5.5	XL	0092	197
		-	UNIVERSAL	0258	315
AVINENT	MODEL	IMPLANT	PLATFORM	CODE	
	HE/EC	3.3//3.5/4	3.5	0023	97
		3.3/3.8/4/4.2/ 4.8//4.5/5	4.1	0024	99
		4.8	5.1	0061	167
	HI/IC	3.1//3.5/4	3.5	0040_B	132
		3.3/3.8/4/4.2/ 4.8//4.5/5	4.1	0040_B	132
	TRANSEPITELIAL	-	REGULAR	0025	101
B&W	MODEL	IMPLANT	PLATFORM	CODE	
	HEXÁGONO EXTERNO	3.75/4	4.1	0024	99
		5	5	0058	161
	CÓNICO HEXAGONO INTERNO CIH	3.3/4	4	0040	129
		3.3/4	4	0042	129
BEGO	MODEL	IMPLANT	PLATFORM	CODE	
	RS/RSX	3.0	3.0	0049	150
	S/RI/RS/RSX	3.25/3.75	3.67	0050	151
		4.1	4.1	0051	153
		4.5	4.5	0052	155
		5.5	5.5	0081	177
	MINI	2.7/2.9/3.1	MINI	0187	275
	MULTIPLUS	-	UNIVERSAL	0150	240

## COMPATIBILITIES AVAILABLE



BIOCONCEPT	MODEL	IMPLANT	PLATFORM	CODE	
	BC TISSUE LEVEL STANDARD	3.3/4.1/4.8	REGULAR	<b>0037</b>	122
	BC TISSUE LEVEL STANDARD PLUS	4.8	REGULAR	<b>0037</b>	122
	BC TISSUE LEVEL TAPERED EFFECT	4.8	REGULAR	<b>0037</b>	122
	BC BONE LEVEL	3.3	NARROW	<b>0033</b>	116
		4.1/4.8	REGULAR	<b>0035</b>	119
	BV TAPERED BONE LEVEL	3.5	NARROW	<b>0029</b>	110
		4/4.5/5	REGULAR	<b>0030</b>	113

BIOGENESIS	MODEL	IMPLANT	PLATFORM	CODE	
	3ICON	3.3	MINI (PINK)	<b>0023</b>	97
		3.75/4/4.3/4.5	REGULAR (BLUE)	<b>0024</b>	99
		5/5.5	WIDE (YELLOW)	<b>0058</b>	161
	ATICON	3.5/4/4.5/5	BLUE	<b>0005</b>	54
	ITICON	3.5/4.1/4.8	4.8	<b>0037</b>	122

BIOHORIZONS	MODEL	IMPLANT	PLATFORM	CODE	
	EXTERNAL	3.5	3.7 (YELLOW)	<b>0023</b>	97
	TAPERED INTERNAL	3/3.4	3 (GREY)	<b>0102</b>	203
		3.8	3.5 (YELLOW)	<b>0040</b>	129
		4.6	4.5 (GREEN)	<b>0041</b>	134
		5.8	5.7 (BLUE)	<b>0080</b>	175
	TAPERED PLUS	3.8	3 (GREY)	<b>0102</b>	203
		4.6	3.5 (YELLOW)	<b>0040</b>	129
		5.28	4.5 (GREEN)	<b>0041</b>	134
	MOUNT-FREE TAPERED INTERNAL	3/3.4	3 (GREY)	<b>0102</b>	203
		3.8	3.5 (YELLOW)	<b>0040</b>	129

## COMPATIBILITIES AVAILABLE



BIOHORIZONS	MODEL	IMPLANT	PLATFORM	CODE		
BIOHORIZONS	MOUNT-FREE TAPERED INTERNAL	4,6	4,5 (GREEN)	<b>0041</b>	134	
		5,8	5,7 (BLUE)	<b>0080</b>	175	
	TAPERED PRO	3,8	3 (GREY)	<b>0102</b>	203	
		4,2/4,6	3,5 (YELLOW)	<b>0040</b>	129	
		5,2	4,5 (GREEN)	<b>0041</b>	134	
	TAPERED SHORT	4,6	3,5 (YELLOW)	<b>0040</b>	129	
		5,8	4,5 (GREEN)	<b>0041</b>	134	
	TAPERED PTG	4,2	3,5 (YELLOW)	<b>0040</b>	129	
	TAPERED IM (INMEDIATE MOLAR)	7/8	5,7 (BLUE)	<b>0080</b>	175	
	TAPERED TISSUE LEVEL	3/3,8	3,5 (YELLOW)	<b>0040</b>	129	
		4,6	4,5 (GREEN)	<b>0041</b>	134	
		5,8	5,7 (BLUE)	<b>0080</b>	175	
	TAPERED PRO CONICAL	3,3/3,8	NARROW (GREY)	<b>0119</b>	212	
		4,2/4,6/5,2	REGULAR (YELLOW)	<b>0120</b>	215	
	MULTI UNIT	-	UNIVERSAL	<b>0025</b>	101	
	BIOMET 3i	OSSEOTITE EXTERNAL HEX	3,25	3,4	<b>0003</b>	49
			3,75/4	4,1	<b>0024</b>	99
			5	5	<b>0058</b>	161
			6	6	<b>0179</b>	
CERTAIN		3,25/4	3,4	<b>0001</b>	43	
		4/5	4,1	<b>0002</b>	46	
		5	5	<b>0057</b>	159	
LOW PROFILE		-	UNIVERSAL	<b>0025</b>	101	
BIOLOK		HEXÁGONO EXTERNO	3,45	3,45	<b>0003</b>	49

## COMPATIBILITIES AVAILABLE



BIONER	MODEL	IMPLANT	PLATFORM	CODE	
	IKELT / BIKELT	3.3/3.75/4	4.1	0024	99
	IKELT	5	5	0058	161
	HIKELT	3.8	3.95	0040	129
		4.7	4.9	0041	134
	TOPDM	3.5	3.5	0021	91
		4	4	0021	91
		5	5	0021	91
	SHORT DM	4/5/6	UNIVERSAL	0021	91
	HIBIKELT	4/5	UNIVERSAL	0021	91
	TRANSEPITELIAL A-5M	Transepitelial A-5M	REGULAR	0025	101
BIOTEC	MODEL	IMPLANT	PLATFORM	CODE	
	SPR/CIM	3.3	3.3	0040	129
		3.75	3.75	0040	129
	SPR/SPTT/CIM	4.2	4.2	0040	129
		5	5	0040	129
BIOTEM	MODEL	IMPLANT	PLATFORM	CODE	
	AR FIXTURE	3.7/4/4.5	REGULAR	0030	113
BREDENT MEDICAL	MODEL	IMPLANT	PLATFORM	CODE	
	NARROW SKY	3.5	NP 3.5	0110	208
BREDENT MEDICAL	MODEL	IMPLANT	PLATFORM	CODE	
	BLUE SKY	3.5/4/4.5/5.5	4	0111	210
	BLUE SKY CLASSIC	3.5/4/4.5	4	0111	210
	COPA SKY	3.5/4/4.5/5/6	3.3	0251	311

## COMPATIBILITIES AVAILABLE



BTI	MODEL	IMPLANT	PLATFORM	CODE	
	EXTERNA TINY	2.5/3.9/3/3.3/ 3.5/3.75	TINY 3,5	0009	64
	EXTERNA UNIVERSAL	3.75/4	UNIVERSAL 4.1	0024	99
	EXTERNA UNIVERSAL PLUS	4.5/5	UNIVERSAL PLUS 4.1	0024	99
	EXTERNA	4.5/5/5.5	ANCHA 5,5	0060	165
	INTERNA	3.3/3.5/3.75	3.5	0257	314
	INTERNA UNIVERSAL	3.3/3.5/3.75/ 4/4.25	UNIVERSAL 4.1	0010	66
	INTERNA UNIVERSAL PLUS	4.5/5/5.5	UNIVERSAL PLUS 4.1	0010	66
	INTERNA ANCHA	5.5/6/6.25	ANCHA 5,5	0059	163
	MULTI-IM	converter 4.1	UNIVERSAL 4.1	0151	241
		converter 5.5	ANCHA 5,5	0177	
BTK	MODEL	IMPLANT	PLATFORM	CODE	
	KLASSIC / KONIC	3.25	3,4 EN	0003	49
	KLASSIC / KONIC/LINE PLUS	3.25PL/3.75/4	4.1 ER	0024	99
	IS +/LINE PLUS IS+	3.3/3.7/4.1/4.8/6	DR	0029	110
	BT SAFE BL	3.3/3.7/4.1/4.8	KR	0029	110
	KLASSIC / KONIC	3.25/4	3,5 IR	0040	129
		3.25/4	3,5 IR	0042	134
	LINE PLUS IC+	3.25/3.75/4.25/5	LR	0040	129
B&W	MODEL	IMPLANT	PLATFORM	CODE	
	HEXÁGONO EXTERNO	3.75/4	3.3	0040	129
		5	3.75	0040	129

## COMPATIBILITIES AVAILABLE



B&W	MODEL	IMPLANT	PLATFORM	CODE	
	CÓNICO HEXAGONO INTERNO CIH	3.3/4	4.2	0040	129
		3.3/4	5	0040	129
CAMLOG	MODEL	IMPLANT	PLATFORM	CODE	
	CAMLOG SCREW-LINE/ PROGRESSIVE-LINE	3.3	3.3	0087	188
		3.8	3.8	0011	68
		4.3	4.3	0012	71
		5	5	0088	190
		3.3	3.3	0119	212
		3.8	3.8	0120	215
		4.3	4.3	0121	218
CONEXÃO SISTEMA DE PRÓTESE	MODEL	IMPLANT	PLATFORM	CODE	
	NP 24° FLESH GOLD	3.5/3.75/4.3/5	UNIVERSAL	0021	125
	NP 24° FLASH	3.5/4.3/5	UNIVERSAL	0021	125
	NP 24° PTERYTRANS EX	3.5	UNIVERSAL	0021	125
	NP 24° SHORT® NP BLT	3.75/4.3	UNIVERSAL	0021	125
	NP 24° TORQ	3.5/3.75/4	UNIVERSAL	0021	125
	NP 24° EXPAND	3.75/4/5	UNIVERSAL	0021	125
CORTEX	MODEL	IMPLANT	PLATFORM	CODE	
	INTERNAL HEX DYNAMIX	3.3/3.8/4.2/5/6	3.75	0040	129
	INTERNAL HEX CLASSIX	3.3/3.8/4.2/5/6	3.75	0040	129
	INTERNAL HEX SATURN	3.8/4.2	3.5	0040	129
	CONICAL DYNAMIX	3	NP	0109	206
		3.3/3.8/4.2	RP	0004	51
		5/6	WP	0005	54

## COMPATIBILITIES AVAILABLE



CORTEX	MODEL	IMPLANT	PLATFORM	CODE	
	CONICAL CLASSIX	3,3/3,8/4,2	RP	0004	51
		5/6	WP	0005	54
	CONICAL MAGIX	3,3/3,8/4,2	RP	0004	51
	MULTI UNIT	-	UNIVERSAL	0025	101
C-TECH	MODEL	IMPLANT	PLATFORM	CODE	
	EL ESTHETIC LINE	3,8/4,3/5,1	4	0246	307
	MULTI UNIT	-	UNIVERSAL	0245	306
COLLELMEDI	MODEL	IMPLANT	PLATFORM	CODE	
	INNO - SUBMERGED TYPE	3,5/4/4,5/5/6	UNIVERSAL	0030	113
	INNO - EXTERNAL TYPE	5,0/6,0	5,1	0061	167
	MULTI S&A ABUTMENT Ø 4,5 MM	Multi S Abutment	UNIVERSAL	0193	281
DENTAL TECH	MODEL	IMPLANT	PLATFORM	CODE	
	IMPLOGIC	4,5	4,5 (BLUE)	0041	134
DENTAURUM	MODEL	IMPLANT	PLATFORM	CODE	
	TIOLOGIC	3,3	SMALL	0130	229
		3,7/4,2	MEDIUM	0131	230
		4,8/5,5	LARGE	0132	231
DENTEGRIS	MODEL	IMPLANT	PLATFORM	CODE	
	SLS-STRAIGHT	4,5	4,5	0041_B	137
	SINUS-LIFT	4,5	4,5	0041_B	137
	S&T IMPLANTS	4,5	4,5	0041_B	137

## COMPATIBILITIES AVAILABLE



DENTEM	MODEL	IMPLANT	PLATFORM	CODE	
	-	-	REGULAR	0030	113

DENTIS	MODEL	IMPLANT	PLATFORM	CODE	
	ONEQ-SL	3	NARROW	0014	75
		3.9/4.2/4.7/5.2	REGULAR	0030	113
		6/7/8	WIDE	0030	113
	S-CLEAN TAPERED / TAPERED II	3.7	MINI	0030	113
		4.1/4.3	REGULAR	0030	113
		4.8	WIDE	0030	113
	S-CLEAN STRAIGHT	4.1/4.8	4.1/4.8	0030	113
	S-CLEAN SAVE	5.5/6	5.5/6	0030	113
	SQ-SL	3.5	NARROW	0014	75
		4/4.5/5	REGULAR	0030	113
		6/7/8	WIDE	0030	113
	E-CLEAN	3.5	MINI	0023	97
		4.1	REGULAR	0024	99
		5.1	WIDE	0061	167

DENTIUM	MODEL	IMPLANT	PLATFORM	CODE	
	NR LINE	3.1	3.2	0190	278
		3.1	3.6	0190	278
		3.6	3.6	0191	279
		4.3	4.3	0191	279
		5	5	0191	279
		6	6	0191	279
	MULTI UNIT NR LINE		5	0192	280
	SIMPLELINE II	3.8/4.3	4.8	0074	170
		3.8/4.3	4.8	0037	122
		4.3/4.8	6.5	0096	199
	SUPERLINE/SUPERLINE II/IMPLANTUM	3.4	3.6	0030	113
		3.8	4	0030	113

## COMPATIBILITIES AVAILABLE



DENTIUM	MODEL	IMPLANT	PLATFORM	CODE	
	SUPERLINE/SUPERLINE II/IMPLANTUM	4.3	4.5	0030	113
		4.8	5	0030	113
		4.8	6	0030	113
	MULTI UNIT AND IMPLANTUM	-	4.5	0193	281

DIO IMPLANTS	MODEL	IMPLANT	PLATFORM	CODE	
	SM SYSTEM	3.8/4.1	NARROW	0076	
		4.5/5/5.3	REGULAR/WIDE	0013	74
	UF II NARROW	3/3.3	NARROW	0014	75
	UF II	3.8/4/4.5/5/5.5	REGULAR	0030	113
	EXTERNAL	3.3/3.8	NARROW 3.5	0023	97
		3.75/4/4.5	REGULAR 4.1	0024	99
		5/5.3/5.5/6	WIDE 5.1	0061	167
	INTERNAL OCTA	-	4.8	0074	170
	MULTI UNIT	-	UNIVERSAL	0247	308

DITRON	MODEL	IMPLANT	PLATFORM	CODE	
	ULTIMATE MATRIX	3.75/4.2	3.75	0040	129
		5	4	0040	129
		6	4.6	0040	129
	MPI MATRIX	3.5	3.5	0040	129
		3.75	3.75	0040	129
		4.2	4.2	0040	129
		5	5	0040	129
		6	6	0040	129

DMI DENTAL SUPPLY	MODEL	IMPLANT	PLATFORM	CODE	
	DCI/DSI	3.3/3.5/3.75/4.2/5/6	3.75	0040	129

## COMPATIBILITIES AVAILABLE



DSP BIOMEDICAL	MODEL	IMPLANT	PLATFORM	CODE	
	HEXÁGONO EXTERNO	3.75/4/5// 3.5/3.8/4.3	4.1	0024	99

EASY IMPLANT	MODEL	IMPLANT	PLATFORM	CODE	
	MASTER C	3.5	3.5 (OCEAN)	0004	51
		4	4 (OCEAN)	0004	51
		4.5	4.5 (LILAS)	0030	113
		5	5 (LILAS)	0030	113
	MASTER S	3.3	3.3 (OCEAN)	0004	51
		3.75	3.75 (LILAS)	0030	113
		4.25	4.25 (LILAS)	0030	113
		4.75	4.75 (LILAS)	0030	113
	MASTER L	3.3	3.3 (LILAS)	0030	113
		3.75	3.75 (LILAS)	0030	113
		4.25	4.25 (LILAS)	0030	113
		4.75	4.75 (LILAS)	0030	113
	MINI	3	3	0176	266
	HEXCEL-S	3.3	3.3	0003	49
		3.75	4.1	0024	99
		4.25	4.1	0024	99
		4.75	5	0058	161
	MULTI UNIT CONICAL ABUTMENT	-	UNIVERSAL	0025	101

ECKERMANN	MODEL	IMPLANT	PLATFORM	CODE	
	ALL-SPIRAL	4	REGULAR	0069	
	DUPLO	4	REGULAR	0070	
	HEXAGON	3/3.5/4/4.5/5	4.1	0024	99
	WINNER	3/3.5/4	3.5	0040_B	132
		3/3.5/4	3.5	0042	129
		4/4.5/5	4.5	0041_B	137
		4/4.5/5	4.5	0043	

## COMPATIBILITIES AVAILABLE



ELITE MEDICA	MODEL	IMPLANT	PLATFORM	CODE	
	CONEXIÓN EXTERNA	3,75	NARROW	<b>0023</b>	97
		4	REGULAR	<b>0024</b>	99
		5	WIDE	<b>0061</b>	167
EUROTEKNIKA	MODEL	IMPLANT	PLATFORM	CODE	
	NATURACTIS	3,5	3,4	<b>0004</b>	51
		4	3,8	<b>0004</b>	51
		4,5	4,3	<b>0004</b>	51
	UNEVA	5	4,8	<b>0004</b>	51
		3,6	4,1	<b>0024</b>	99
		4,1	4,1	<b>0024</b>	99
	UNEVA (PLATFORM SWITCHING)	4,8	4,1	<b>0024</b>	99
		6	4,1	<b>0024</b>	99
	NATEA	3,6/4,1/4,8	NARROW	<b>0004</b>	51
		3,6/4,1/4,8	REGULAR	<b>0004</b>	51
		6	WIDE	<b>0004</b>	51
	AESTHETICA	4,1	4,8	<b>0074</b>	170
		4,1	4,8	<b>0037</b>	122
		4,8	6,5	<b>0096</b>	199
	NATURALL	3,5	NARROW	<b>0004</b>	51
		4/4,5	REGULAR	<b>0004</b>	51
		5	WIDE	<b>0004</b>	51
	IBONE E/IBONE S	3,8/4,3/4,8	3,5	<b>0004</b>	51
		4,8/5,5/6,2	4,3	<b>0004</b>	51
	IBONE G	4,8/5,5	RP	<b>0037</b>	122
		5,5/6,2	WP	<b>0096</b>	199
	MULTI UNIT TETRA	Universal	UNIVERSAL	<b>0025</b>	101
F&B IMPLANT (FIT & BRILLIANT)	MODEL	IMPLANT	PLATFORM	CODE	
	FA SUBMERGED FIXTURE	3,9	NARROW	<b>0030</b>	113
		4,1/4,4	REGULAR	<b>0030</b>	113

## COMPATIBILITIES AVAILABLE



F&B IMPLANT (FIT & BRILLIANT)	MODEL	IMPLANT	PLATFORM	CODE	
	FA SUBMERGED FIXTURE	4,8	WIDE	<b>0030</b>	113
		5,3/5,8/6,3/6,8	ULTRA-WIDE	<b>0030</b>	113
GALIMPLANT	MODEL	IMPLANT	PLATFORM	CODE	
	CONEXIÓN EXTERNA	3,5/4	4	<b>0024</b>	99
	CONEXIÓN INTERNA	3,5	3,5	<b>0004</b>	51
		4	4	<b>0004</b>	51
		5	5	<b>0004</b>	51
	PILAR MULTI-POSICION RECTO / PILAR MULTI- POSICION ANGULADO	Universal	UNIVERSAL	<b>0025</b>	101
GC TECH	MODEL	IMPLANT	PLATFORM	CODE	
	AADVA STANDARD / TAPERED IMPLANTS	3,3	NARROW	<b>0196</b>	285
		4	REGULAR	<b>0197</b>	286
		5	WIDE	<b>0198</b>	287
GLOBAL D (TEKKA)	MODEL	IMPLANT	PLATFORM	CODE	
	IN-KONE UNIVERSAL	3,5/4/4,5/5	UNIVERSAL	<b>0152</b>	
	IN-KONE PRIMO	3,5/4/4,5/5	UNIVERSAL	<b>0152</b>	
GMI (ILERIMPLANT)	MODEL	IMPLANT	PLATFORM	CODE	
	AVANTGARD	3,75/4,25	RP	<b>0243</b>	305
	PHOENIX	3,3/3,75/4	STANDARD 4,1	<b>0024</b>	99
		5	WIDE 5,1	<b>0061</b>	167
	FRONTIER	3,3/3,75/4,25	RP 3,3	<b>0040_B</b>	132
		3,3/3,75/4,25	RP 3,3	<b>0042_B</b>	
		4,75/5,75	WP 4,3	<b>0041_B</b>	137
	UNIVERSAL	Universal	PS-RP 4,8	<b>0025</b>	101

## COMPATIBILITIES AVAILABLE



GT MEDICAL	MODEL	IMPLANT	PLATFORM	CODE	
	BEST FIT HEXÁGONO INTERNO	3.7/4.1/4.3/4.8	WIDE	<b>0005</b>	54
		3.7/4.3/4.8	REGULAR	<b>0074</b>	170
		3.7/4.3/4.8	REGULAR	<b>0037</b>	122
	BEST FIT HEXÁGONO EXTERNO	3.5	NARROW	<b>0023</b>	97
		4.1	REGULAR	<b>0024</b>	99
		5.1	WIDE	<b>0061</b>	167

HAHN IMPLANT (GLIDEWELL)	MODEL	IMPLANT	PLATFORM	CODE	
	HAHN TAPERED IMPLANT	3	3	<b>0159</b>	244
		3.5/4.3	3.5/4.3	<b>0021</b>	91
		5	5	<b>0022</b>	94
		7	7	<b>0124</b>	221
	MULTI-UNIT ABUTMENT SYSTEM	Universal	UNIVERSAL	<b>0025</b>	101

HIOSSEN	MODEL	IMPLANT	PLATFORM	CODE	
	ETII SA / ETIII SA	3.5	MINI	<b>0029</b>	110
		4/4.5/5	REGULAR	<b>0030</b>	113
	ETII SA / ETIII SA / ETIV SA	4/4.5/5	REGULAR	<b>0030</b>	113
		4/4.5/5	REGULAR	<b>0030</b>	113
	ETIII BA	3.5	MINI	<b>0029</b>	110
		4/4.5/5	REGULAR	<b>0030</b>	113

HI-TEC	MODEL	IMPLANT	PLATFORM	CODE	
	TAPERED SELF THREAD	3.3/3.75	3.5	<b>0040</b>	129
		4.2/5	4.5	<b>0041</b>	134
	LOGIC PLUS	3.5	3.7	<b>0040</b>	129
		4.3	3.9	<b>0040</b>	129
		5/6	4.1	<b>0040</b>	129
	LOGIC / IMPLEX	3/3.5	3.5	<b>0021</b>	91
		3.5	3.9	<b>0021</b>	91
		4.3/5/6	3.9	<b>0022</b>	91

## COMPATIBILITIES AVAILABLE



IBS	MODEL	IMPLANT	PLATFORM	CODE	
	MAGIC FC	4/4.5/5/5.5/ 6/6.5	3.8	<b>0030</b>	113
	N.R. FIX	3/3.5	3.8	<b>0030</b>	113
IDO IMPLANTS	MODEL	IMPLANT	PLATFORM	CODE	
	I Do Implant	3.8/4/4.5/5/ 5.5/6/7	UNIVERSAL	<b>0030</b>	113
IHDE DENTAL (IMBIODENT)	MODEL	IMPLANT	PLATFORM	CODE	
	BONE LEVEL PLUS	3.3	3.3	<b>0033</b>	116
		4.1	4.1	<b>0035</b>	119
		4.8	4.8	<b>0035</b>	119
IMPLANT DIRECT	MODEL	IMPLANT	PLATFORM	CODE	
	REPLUS / REPLANT / REACTIVE	3.5/3.7/4.2	3.5	<b>0026</b>	104
		4.3/4.7	4.3	<b>0027</b>	106
		5/5.7	5	<b>0028</b>	108
	LEGACY	3.7/4.2	3.5	<b>0040</b>	129
		4.7/5.2	4.5	<b>0041</b>	134
	SWISHPLANT / SWISHPLUS	4.1/4.8	4.8	<b>0074</b>	170
		4.1/4.8	4.8	<b>0037</b>	122
		4.8/5.7	6.5	<b>0096</b>	199
	SWISHACTIVE	3.3	3	<b>0021</b>	91
		4.1/4.8	3.4	<b>0022</b>	94
	INTERACTIVE	3.2/3.7	3	<b>0021</b>	91
		4.3/5	3.4	<b>0022</b>	94
	SIMPLY ICONIC	3.2/3.7/4.2	PURPLE 3.0	<b>0021</b>	91
		4.7/5.2/5.7	GOLD 3.4	<b>0022</b>	94
	MULTI UNIT ABUTMENT	-	5	<b>0158</b>	243

## COMPATIBILITIES AVAILABLE



IMPLANT GENESIS	MODEL	IMPLANT	PLATFORM	CODE	
	AKTIV SYSTEM	3.5/3.75/4.2/5	STANDARD	0040	129

IMPLANTSWISS	MODEL	IMPLANT	PLATFORM	CODE	
	BONE LEVEL	3.3	3.3	0004	51
		3.7	3.7	0030	113
		4.3	4.3	0030	113
		4.8	4.8	0030	113
	MULTI UNIT ABUTMENT	5.5	5.5	0030	113
		Universal	4.8	0025	101

INTRA-LOCK	MODEL	IMPLANT	PLATFORM	CODE	
	UNIHEX	4	REGULAR	0024	99
		4.75	WIDE	0024	99
	INTRAHX	3.75/4	3.5	0040	129
		4.75	4.5	0041	134

JDENTALCARE	MODEL	IMPLANT	PLATFORM	CODE	
	JDEVOLUTION/ JDEVOLUTION PLUS	3.7	3.7	0040	129
		4.3/5	4	0040	129
		6	5	0040	129
	JD PTERYGO	4	4	0040	129
	JD ICON/JD ICON F	3.9	3.9	0022	94
		4.3	4	0022	94
		5	4.7	0022	94
	JD ICON PLUS	3.7	3.7	0015	78
		4.3	4	0015	78
		5	4.8	0015	78
	JD ICON PLUS T	3.5	3.5	0015	78
		4	3.5	0015	78
		4.5	3.5	0015	78
	CONICAL ABUTMENT	-	UNIVERSAL	0025	101

## COMPATIBILITIES AVAILABLE



KEYSTONE	MODEL	IMPLANT	PLATFORM	CODE	
	RESTORE	3,75/4	RD 4,1	<b>0024</b>	99
		5/6	WD 5	<b>0061</b>	167
	INTERNAL TILOBE PRIMA CONNEX	3,3/3,5	3,5	<b>0044</b>	139
		4/4,1	4,1	<b>0045</b>	141
		5	5	<b>0046</b>	143
	INTERNAL TILOBE PRIMA PLUS	3,5	3,5	<b>0044</b>	139
		4,1	4,1	<b>0045</b>	141
		5/6	5	<b>0046</b>	143

KLOCKNER	MODEL	IMPLANT	PLATFORM	CODE	
	ESSENTIAL CONE	3,5/4/4,5	4,5	<b>0054</b>	157
		4,8	6	<b>0071</b>	
	ESSENTIAL CONE PILAR 25°	3,5/4/4,5	4,5	<b>0054</b>	157
	ESSENTIAL CONE OCTACONE 12°	3,5/4/4,5	4,5	<b>0054</b>	157
	KL	3,3	NARROW	<b>0023</b>	97
		3,7/4,2	REGULAR	<b>0024</b>	99
		4,7	WIDE	<b>0061</b>	167
	VEGA	3	MV	<b>0180</b>	
		3,5	NV	<b>0082</b>	178
		4/4,5	RV	<b>0083</b>	180
	VEGA+	3,6	NV	<b>0082</b>	179
		4,1/4,6	RV	<b>0083</b>	181
	MULTI UNIT PERMANENT	4,2	UNIVERSAL	<b>0173</b>	265

KUWOTECH	MODEL	IMPLANT	PLATFORM	CODE	
	BIONIQ	2,9	QN (AMARILLO)	<b>0166</b>	254
		3,5	QR (AZUL)	<b>0167</b>	256
		4	QR (AZUL)	<b>0167</b>	256

## COMPATIBILITIES AVAILABLE



LASAK	MODEL	IMPLANT	PLATFORM	CODE	
	BIONIQ	2,9	QN (AMARILLO)	0166	254
		3,5	QR (AZUL)	0167	256
		4	QR (AZUL)	0167	256
		5	QR (AZUL)	0167	256

LEADER	MODEL	IMPLANT	PLATFORM	CODE	
	TIXOS INTERNAL HEX	3,3	3,5	0040	129
		3,75	4	0040	129
		3,3/3,75	4,1	0024	99
		5	5	0058	161

MEDENTIKA	MODEL	IMPLANT	PLATFORM	CODE	
	MULTI UNIT	-	UNIVERSAL	0025	101

MEDENTIS	MODEL	IMPLANT	PLATFORM	CODE	
	PREMIUM / ACTIVE MASTER	3,3	3,3 (PINK)	0249	309
		3,75	3,75 (RED)	0125	223
		4,1	4,1 (GREEN)	0125	223
		4,8	4,8 (BLUE)	0125	223

MEGAGEN	MODEL	IMPLANT	PLATFORM	CODE	
	ANYRIDGE	3,5	SMALL	0015	78
		4/4,5	REGULAR	0015	78
		5/5,5	WIDE	0015	78
	ANYONE INTERNAL	3,5/4/4,5/5/6/7	GENERAL	0030	113
	ANYONE EXTERNAL	3,5	SMALL 3,5	0023	97
		4	REGULAR 4,1	0024	99
		4,5	REGULAR 4,5	0024	99
		5	WIDE 5	0058	161
		6	SUPERWIDE 5,5	0058	161
	CONE ABUTMENT	Universal	3,8	0128	226
		Universal	4,8	0074	170

## COMPATIBILITIES AVAILABLE



MEGAGEN	MODEL	IMPLANT	PLATFORM	CODE	
	MINI NARROW RIDGE	3/3.4	MINI	0014	75
	EXFEEL	3.5	SMALL	0037	122
		4.1	REGULAR	0037	122
		4.8/5	WIDE	0037	122
	BLUE DIAMOND/BD CUFF/ANYRIDGE OCTA	3.3/3.7	NC	0222	296
		4.1/4.4/4.8/5.3/5.8/6.3	RC	0223	298
	MULTI UNIT N TYPE	Multi Unit N Type	UNIVERSAL	0025	101
		Multi Unit S Type	UNIVERSAL	0264	324
MICRODENT	MODEL	IMPLANT	PLATFORM	CODE	
	UNIVERSAL	2.8/3.25	3.5	0003	49
		3.3/3.5/3.75/4	4.1	0024	99
		4.2/5	5.1	0058	161
	SYSTEM	2.8/3.25	3.5	0003	49
	EKTOS	3.7/4.2	3.5	0040_B	132
MIS	MODEL	IMPLANT	PLATFORM	CODE	
	LANCE	3.75/4.2	STANDARD	0024	99
		5	WIDE	0058	161
	MULTI-UNIT	-	GENERAL	0020	89
	SEVEN	3.3	NARROW	0019	87
		3.75/4.2	STANDARD	0040	129
		5/6	WIDE	0041	134
	M4	3.3	NARROW	0019	87
		3.75/4.2	STANDARD	0040	129
		5/6	WIDE	0041	134
	C1	3.3	NARROW	0016	81
		3.75/4.2	STANDARD	0017	83
		5	WIDE	0018	85
	V3	3.9/4.3/5	STANDARD	0017	83

## COMPATIBILITIES AVAILABLE



MONOIMPLANT	MODEL	IMPLANT	PLATFORM	CODE	
	MONOIMPLANT MULTI UNIT	3/3.7/4.1	4,8	<b>0025</b>	101

---

MOZO-GRAU (TICARE)	MODEL	IMPLANT	PLATFORM	CODE	
MG OSSEOUS		3.3	3.4 MINI	<b>0003</b>	49
		3.4/3.75/4.25	4.1 STANDARD	<b>0024</b>	99
		5	5 MAXI	<b>0061</b>	167
MG INHEX		-	CON 450	<b>0067</b>	
		3.3	2,3 MINI	<b>0109</b>	206
		3.75/4.25	2,8 STANDARD	<b>0004</b>	51
		5	3,8 MAXI	<b>0005</b>	54

---

MPI	MODEL	IMPLANT	PLATFORM	CODE	
CONEXIÓN EXTERNA HE PRIVILEGE		3.3	3.5	<b>0009</b>	64
		3.3/4	4.1	<b>0024</b>	99
		5	5	<b>0058</b>	161
PRIVILEGE CM		3.5/4	REGULAR	<b>0004</b>	51
		5	WIDE	<b>0005</b>	54
EXCELLENCE CM		3.5/4	REGULAR	<b>0004</b>	51
		5	WIDE	<b>0005</b>	54

---

NEOBIOTECH	MODEL	IMPLANT	PLATFORM	CODE	
EB EXTERNAL SYSTEM		3.5	NARROW	<b>0023</b>	97
IS IMPLANT SYSTEM		3.2	S-NARROW	<b>0029</b>	110
		3.5	NARROW	<b>0030</b>	113
		4	REGULAR	<b>0030</b>	113
		4.5	REGULAR	<b>0030</b>	113
		5	WIDE	<b>0030</b>	113
		-	4,8	<b>0025</b>	101

---

NEODENT	MODEL	IMPLANT	PLATFORM	CODE	
	HELIX GM/DRIVE GM/ TITAMAX GM	3.5/3.75/4/ 4.3/5/6	REGULAR	<b>0186</b>	272

## COMPATIBILITIES AVAILABLE



NEODENT	MODEL	IMPLANT	PLATFORM	CODE	
	SMART HE	3,75/4	4.1	0024	99
	HELIX HE	3,75/4/4.3	4.1	0024	99
	MINI PILAR CM / MINI PILAR ANGULADO CM	Mini Pilar CM / Mini Pilar Angulado CM	UNIVERSAL	0025	101

NEOSS	MODEL	IMPLANT	PLATFORM	CODE	
	PROACTIVE STRAIGHT/ TAPERED/EDGE	3,25 Royal Blue	3,25	0144	
		3,5 Green	STANDARD	0047	145
		4 Yellow	STANDARD	0047	145
		4,5 Blue	STANDARD	0048	147
		5 Peach	STANDARD	0048	147
		5,5 Lilac	STANDARD	0048	147
	PROACTIVE WIDE	6	STANDARD	0048	147
	PROACTIVE SINUS	6,5	STANDARD	0048	147
	SHORT IMPLANT	3,5/4/4,5	STANDARD	0047	145
		5/5,5/6/6,5	STANDARD	0048	147

NOBEL BIOCARE	MODEL	IMPLANT	PLATFORM	CODE	
	BRANEMARK	3.3	NARROW	0023	97
		3,75/4	REGULAR	0024	99
		5/6	WIDE	0061	167
	REPLACE	3.5	NARROW	0026	104
		4.3	REGULAR	0027	106
		5	WIDE	0028	108
		6	PLATFORM 6	0129	227
	ACTIVE/REPLACE	3	MINI 3.0	0159	244
		3.5	NARROW	0021	91
		4.3/5	REGULAR	0022	94
		5.5	WIDE	0124	221
	NOBELSPEEDY	3.3	NARROW	0023	97
		4/5	REGULAR	0024	99
		5/6	WIDE	0061	167

## COMPATIBILITIES AVAILABLE



NOBEL BIOCARE	MODEL	IMPLANT	PLATFORM	CODE	
	NOBELPARALLEL	3.75	NARROW	0021	91
		4.3/5	REGULAR	0022	94
		5.5	WIDE	0124	221

NORIS MEDICAL	MODEL	IMPLANT	PLATFORM	CODE	
	TUFF	3.3/3.75/4.2/5/6	3.75	0040	129
	TUFF TT	3.3/3.75/4.2/5/6	3.75	0040	129
	ONIX	3.3/3.75/4.2/5/6	3.75	0040	129
	CORTICAL	4.0/5/6	3.75	0040	129
	PTERYCORE	4.2	3.75	0040	129
	PTERYFIT	4.2	3.75	0040	129

NORMON	MODEL	IMPLANT	PLATFORM	CODE	
	NORMOIMPLANT HE	3.25/3.75/4.25/ 4.75	4.1	0024	129
	NORMOIMPLANT HI	3.75/4.25/4.75	3.5	0040_B	132

NOVA IMPLANTS	MODEL	IMPLANT	PLATFORM	CODE	
	PSI/PCI	3.3/3.75/4.2/5/6	3.75	0040_B	132

OSSTEM IMPLANT	MODEL	IMPLANT	PLATFORM	CODE	
	TS	3	MINI 3.0	0029	110
		3.5	MINI 3.5	0029	110
		4/4.5/5/6/7	REGULAR	0030	113
	US	3.3/3.5	MINI 3.5	0023	97
		3.75/4/4.5	REGULAR 4.1	0024	99
		5/5.5	WIDE 5.1	0061	167
		5/5.5	WIDE PS 5	0058	160

## COMPATIBILITIES AVAILABLE



OSSTEM IMPLANT	MODEL	IMPLANT	PLATFORM	CODE	
	MULTI UNIT ABUTMENT/ESTHETIC LOW ABUTMENT	Universal	MINI/REGULAR	<b>0025</b>	101

OSTEOPLUS	MODEL	IMPLANT	PLATFORM	CODE	
	SHE	3.45	3.45	<b>0009</b>	64
		3.75 / 4	4	<b>0024</b>	99
	SHI	3.3 / 3.75 / 4.2	3.5	<b>0040</b>	129

OXY	MODEL	IMPLANT	PLATFORM	CODE	
	K1 LINE	3.5/4/4.5/5	REGULAR	<b>0015</b>	78
		5.5/6/6.5	WIDE	<b>0015</b>	78
	PSK LINE	3.5/4/4.5/5	REGULAR	<b>0015</b>	78
	MD LINE KONE	3.75/4.25/5	REGULAR	<b>0015</b>	78
	MD LINE EXT	3.75/4.25	STANDARD	<b>0024</b>	99
	FIXO	Universal	4,8	<b>0242</b>	303

PALTOP	MODEL	IMPLANT	PLATFORM	CODE	
	ADVANCED CLASSIC	3.25	NARROW (BLUE)	<b>0229</b>	300
		3.75/4.2/5	STANDARD	<b>0040_B</b>	132
		3.75/4.2/5	STANDARD	<b>0042</b>	129
		6	WIDE (PURPLE)	<b>0041</b>	134
	ADVANCED +	3.25	NARROW (BLUE)	<b>0229</b>	300
		3.75/4.2/5	STANDARD	<b>0040_B</b>	132
		3.75/4.2/5	STANDARD	<b>0042</b>	129
		6	WIDE (PURPLE)	<b>0041</b>	134
	DYNAMIC	3.25	NARROW (BLUE)	<b>0229</b>	300
		3.75/4.2/5	STANDARD	<b>0040_B</b>	132
		3.75/4.2/5	STANDARD	<b>0042</b>	129
		6	WIDE (PURPLE)	<b>0041</b>	134

## COMPATIBILITIES AVAILABLE



PALTOP	MODEL	IMPLANT	PLATFORM	CODE	
	PAI	3,25	NARROW (BLUE)	0229	300
		3,75/4,2/5	STANDARD	0040_B	132
		3,75/4,2/5	STANDARD	0042	129
		6	WIDE (PURPLE)	0041	134
	DIVA/ACTIVE	3,75/4,2/5	STANDARD	0040_B	132
		3,75/4,2/5	STANDARD	0042	129
	CONICAL ACTIVE	3,25/3,75/4,2/5	STANDARD	0029/0182	110
	UNIVERSAL MULTI-UNIT	Multi-Unit	UNIVERSAL	0181	268

P-I BRANEMARK	MODEL	IMPLANT	PLATFORM	CODE	
	MT	3,3	3,5 (RED)	0178	267
		3,75	4,1 (GREEN)	0178	267
		4,8	5,1 (YELLOW)	0178	267

PHIBO	MODEL	IMPLANT	PLATFORM	CODE	
	TSH/BNT SERIE 3	3,6	4	0024	99
	TSH/BNT SERIE 4	4,2	4	0024	99
	TSH/BNT SERIE 5	4,8	5	0060	165

POINT IMPLANT	MODEL	IMPLANT	PLATFORM	CODE	
	SM II SYSTEM UV IMPLANT	4/4,5/5	REGULAR	0030	113

PROCLINIC	MODEL	IMPLANT	PLATFORM	CODE	
	CILINDRICO EXTERNO	3,3	3,3 MINI	0009	64
	CILINDRICO EXTERNO/ CÓNICO EXTERNO	3,75/4,25//3,5/4	4,1 ESTANDAR	0024	99
		5	5 MAXI	0058	161
		3,3/3,75/4,25/5// 3,5/4/5	3,5	0040	129

## COMPATIBILITIES AVAILABLE



PROCLINIC	MODEL	IMPLANT	PLATFORM	CODE	
	SP OCTA	3.3/4.1/4.8	4.8	0074	170
		3.3/4.1/4.8	4.8	0037	122
		4.8	6.5	0096	199
	AQUA CM	3.5/4/5	2.82	0004	51
PROTEG IMPLANTS	MODEL	IMPLANT	PLATFORM	CODE	
	PR01	3.3/3.75/4.2/5/6	NARROW	0265	325
RADHEX	MODEL	IMPLANT	PLATFORM	CODE	
	PHE	3.5	3.5	0023	97
		4/4.5/5	4.1	0024	99
	PHI	3.75	3.5	0040_B	132
		4.5/5	4.5	0041_B	136
REFLECT	MODEL	IMPLANT	PLATFORM	CODE	
	RAPID	3.0	3.0	0159	244
		3.5	NP	0021	91
		4.3/5/5.5	RP	0022	94
	RECOVER	3.5	NP	0021	91
		4.3/5	RP	0022	94
	ASPIRE	3.5/4	AQUA (ESTRECHA)	0004	51
		5	LILAC (ANCHA)	0005	54
	TAPERED SCREW	3.5	3.5	0040	129
		4.1/4.7	4.5	0041	134
RITTER	MODEL	IMPLANT	PLATFORM	CODE	
	SB/LA/QSI	3.75/4.2/5/6	STANDARD	0040_B	132

## COMPATIBILITIES AVAILABLE



ROOTT	MODEL	IMPLANT	PLATFORM	CODE	
	R	3.5/3.8/4.2/ 4.8/5.5	UNIVERSAL	<b>0236</b>	301

SEWON MEDIX	MODEL	IMPLANT	PLATFORM	CODE	
	IH <sub>2</sub> SLA SYSTEM	3.5	MINI	<b>0029</b>	110
		3.5/4/4.5/5	REGULAR	<b>0030</b>	113
	IH <sub>2</sub> RBM SYSTEM	3.5	MINI	<b>0029</b>	110
		3.5/4/4.5/5	REGULAR	<b>0030</b>	113
	IH SYSTEM	3.5/4/4.5/5	UNIVERSAL	<b>0025</b>	101

SIC INVENT	MODEL	IMPLANT	PLATFORM	CODE	
	HEXAGONAL SYSTEM SICACE	3.4/4	3.3	<b>0170</b>	261
		4.5/5	4.2	<b>0171</b>	263
	HEXAGONAL SYSTEM SICMAX	3.4/4.2	3.3	<b>0170</b>	261
		4.7/5.2	4.2	<b>0171</b>	263
	HEXAGONAL SYSTEM SICTAPERED	3.4/4.2	3.3	<b>0170</b>	261
		4.7/5.2	4.2	<b>0171</b>	263

SIGNO VINCES	MODEL	IMPLANT	PLATFORM	CODE	
	DUO	3.8	3.3	<b>0078</b>	
		4.6	4.1	<b>0024</b>	99
	INTTEGRA	3.25	3.3	<b>0078</b>	
		3.75/4	4.1	<b>0024</b>	99
	COMPACT	4.5	CM3,8	<b>0004</b>	51
	DUOCON	3.8	CM3,8	<b>0004</b>	51
		4.6/5.5	CM4,6	<b>0005</b>	54
	INFRA	3.3/3.8/4.6	CM	<b>0004</b>	51

## COMPATIBILITIES AVAILABLE



SIN IMPLANTS	MODEL	IMPLANT	PLATFORM	CODE	
	HE	3.75	4.1	0024	99
	HI SW	3.8	3.8	0039	127
	TRYON	3.25/3.75/4	4.1	0024	99
	TRYON CO	4	4.1	0024	99
	REVOLUTION	3.25/3.75/4	4.1	0024	99
	STYLUS	4	4.1	0024	99
	EPIKUT/EPIKUT PLUS	3.5/3.8/4.5/5	UNIVERSAL	0230	
		4.5	4.5	0024	99
		5	5	0058	160
	MINI PILAR	Universal	UNIVERSAL	0025	101

SOUTHERN IMPLANTS	MODEL	IMPLANT	PLATFORM	CODE	
	TRI-NEX	3.5	3.5	0026	104
		4.3	4.3	0027	106
		5	5	0028	108
		6	6	0129	227
	IT CONNECTION	3.3/4/4.1/4.9/5	4.8	0037	122
		4.9/5/6	6.5	0096	199
	EXTERNAL HEX	3.25	3.4	0003	49
		3.75/4	4.1	0024	99
		4.7/5	5	0058	161
		5.7/6	6	0058	161
	DEEP CONICAL	3	2.45	0109	206
		3.5/4	2.95/3.1	0004	51
		5	4.1	0005	54
	INTERNAL HEX	3.75/4.2/5	UNIVERSAL	0040	129
	PROVATA	4/5/6	STANDARD	0040	129
	COMPACT CONICAL	4.8	4.8	0025	101

## COMPATIBILITIES AVAILABLE



STERI-OSS	MODEL	IMPLANT	PLATFORM	CODE	
	HEX-LOC	3,25	3,3	<b>0023</b>	97
STERNGOLD	MODEL	IMPLANT	PLATFORM	CODE	
	STERN EX	3,75/4/5	4,1	<b>0024</b>	99
STRAUMANN	MODEL	IMPLANT	PLATFORM	CODE	
TISSUE LEVEL		3,3	3,5	<b>0160</b>	243
		3,3/4,1/4,8	REGULAR 4,8	<b>0037</b>	122
		4,8	WIDE 6,5	<b>0096</b>	199
SYNOCTA		-	REGULAR 4,8	<b>0074</b>	170
		-	WIDE 6,5	<b>0137</b>	236
BONE LEVEL TAPERED SC		2,9	SC- 2,9	<b>0135</b>	232
BONE LEVEL		3,3	NC- 3,3	<b>0033</b>	116
		4,1	RC-4,1	<b>0035</b>	119
		4,8	RC-4,8	<b>0035</b>	119
SCREW-RETAINED		NC/RC Ø4,6	UNIVERSAL	<b>0101</b>	201
BLX		3,5/3,75/4/4,5	RB (REGULAR BASE)	<b>0207</b>	290
		5/5,5/6,5	WB (WIDE BASE)	<b>0208</b>	293
BLC		3,3/3,75	RB	<b>0207</b>	290
		4,5/5,5/6,5	WB	<b>0208</b>	293
TLX / TLX S		3,75/4,5	NT	<b>0260</b>	315
		3,75/4,5	RT	<b>0261</b>	318
		5,5/6,5	WT	<b>0262</b>	321
TLC		3,3	NT	<b>0260</b>	318
		3,3/3,75/4,5	RT	<b>0261</b>	320
		4,5/5,5/6,5	WT	<b>0262</b>	322
SURCAM DENTAL	MODEL	IMPLANT	PLATFORM	CODE	
	MULTI-UNIT	-	UNIVERSAL	<b>0181</b>	268

## COMPATIBILITIES AVAILABLE



SYBRON IMPLANT SOLUTIONS	MODEL	IMPLANT	PLATFORM	CODE	
	ENDOPORE (INNOVA)	4.1	4.1	<b>0024</b>	99
SYSTHEX	MODEL	IMPLANT	PLATFORM	CODE	
	CLASSIC-CI / ESTETIC-CI	3.5/3.75/4	4.1	<b>0024</b>	99
TBR	MODEL	IMPLANT	PLATFORM	CODE	
	HEX-CONIC	3.5	NARROW	<b>0023</b>	97
		5	WIDE	<b>0058</b>	161
	CONNECT / INFINITY	3.5	3.5	<b>0266</b>	326
		4	4	<b>0267</b>	327
		5	5	<b>0268</b>	328
	BABY 8	4	4	<b>0267</b>	327
		5	5	<b>0268</b>	328
TITANIUM-FIX	MODEL	IMPLANT	PLATFORM	CODE	
	B-FIX	3.5/4	REGULAR	<b>0004</b>	51
		4.5/5	LARGA	<b>0005</b>	54
TREE-OSS	MODEL	IMPLANT	PLATFORM	CODE	
	SIMPLE	3.3/3.75/5	3.75 AMARILLO	<b>0040</b>	129
	RAPID/ANATOMIC	3.3	3.5 ROSA	<b>0023</b>	97
		3.75/4	4.1 AMARILLO	<b>0024</b>	99
		5	5.1 AZUL	<b>0061</b>	167
	ANATOMIC/HS	3.5	3.5 ROSA	<b>0026</b>	104
		4.3	4.3 AMARILLO	<b>0027</b>	106
		5	5 AZUL	<b>0028</b>	108
	MULTI UNIT	-	UNIVERSAL	<b>0025</b>	101

## COMPATIBILITIES AVAILABLE



TRI DENTAL IMPLANTS	MODEL	IMPLANT	PLATFORM	CODE	
	TRI-VENT	3.75/4.1/4.7	3.5	0040	129
		3.75/4.1/4.7	3.5	0042	129

TRINON	MODEL	IMPLANT	PLATFORM	CODE	
	Q2	3.5/3.75/4.5	4	0024	99
	QK	4	4.8	0074	170
		4	4.8	0037	122

UFIT	MODEL	IMPLANT	PLATFORM	CODE	
	GT2	3.5	MINI	0004	51
		4/4.5	REGULAR	0005	54
		5	WIDE	0005	54
		5.5/6/6.5/7	ULTRA-WIDE	0005	54
	NT2	3.5	MINI	0004	51
		4/4.5	REGULAR	0005	54
		5	WIDE	0005	54
		5.5/6/6.5/7	ULTRA-WIDE	0005	54

VULKAN IMPLANTS	MODEL	IMPLANT	PLATFORM	CODE	
	IN-HEX	3.3/3.75/4.2/5	3.75	0040	129

WARANTEC (ONEPLANT)	MODEL	IMPLANT	PLATFORM	CODE	
	IU IMPLANT SYSTEM	3.3/3.6	MINI	0004	51
		3.6	MINI	0004	51

WIN	MODEL	IMPLANT	PLATFORM	CODE	
	WIN	3.30/3.75/4.25/5	3.75	0040_B	132
		Universal	UNIVERSAL	0025	101

## COMPATIBILITIES AVAILABLE



XIVE	MODEL	IMPLANT	PLATFORM	CODE	
	XIVE	3	3	0084	183
		3.4	3.4	0038	125
		3.8	3.8	0039	127
		4.5	4.5	0085	184
		5.5	5.5	0086	186

YES IMPLANT	MODEL	IMPLANT	PLATFORM	CODE	
	S-SYSTEM	3.3/3.5	NARROW	0030	113
		4/4.5	REGULAR	0030	113
		5/5.5	WIDE	0030	113

YOUSE IMPLANTS (Sweden & Martina Group)	MODEL	IMPLANT	PLATFORM	CODE	
	YOUSE-V/YOUSE-VL	3.3/3.7	NARROW	0021	91
		4.2/5	REGULAR	0022	94

ZIACOM	MODEL	IMPLANT	PLATFORM	CODE	
	OEX	3.75/4.25	RP 4.1	0024	99
	ZINIC	3.7/4/4.3	RP 3.5	0040_B	132
	ZINIC SHORTY	4.75	RP 3.5	0040_B	132
	GALAXY	3.4/3.7/4	RP 2.85	0004	51

  

ZIMMER	MODEL	IMPLANT	PLATFORM	CODE	
	SCREW-VENT	3.7/4.1	3.5	0040	129
		3.7/4.1	3.5	0042	129
		4.7	4.5	0041	134
		4.7	4.5	0043	
		6	5.7	0080	175
	TSX IMPLANT	3.1	2.9	0178	267
		3.7/4.1/4.7	3.5	0040	129
		3.7/4.1/4.7	3.5	0042	129

## COMPATIBILITIES AVAILABLE



ZIMMER	MODEL	IMPLANT	PLATFORM	CODE	
TSX IMPLANT		5.4/6	4.5	<b>0041</b>	134
		5.4/6	4.5	<b>0043</b>	
SWISS-PLUS		3,7/4,1/4,8	4,8	<b>0074</b>	170
		3,7/4,1/4,8	4,8	<b>0037</b>	122
EZTETIC		3,1	2,9	<b>0178</b>	267
TAPERED ABUTMENT		Universal	UNIVERSAL	<b>0205</b>	288

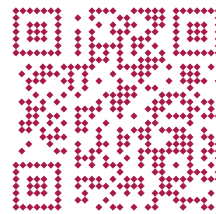

This printed version is probably outdated and may not include all products or compatibilities.

**Scan and download the latest version of this catalogue**

[www.dynamicabutment.com](http://www.dynamicabutment.com)

# MULTI-UNIT DAS SYSTEM

# DYNAMIC DAS SYSTEM

LIBRARY OPTIONS: GH = Gingival Height CH = Cement Height H = Height IG = Adaptor 3mm  $\alpha_1$  = Standard maximum angulation  $\alpha_2$  = Standard maximum angulation  $\alpha_{di}$  = Direct to implant maximum angulation

# COMPATIBLE WITH 0001

LIST OF COMPATIBILITIES **AVAILABLE**  
BIOMET 3L

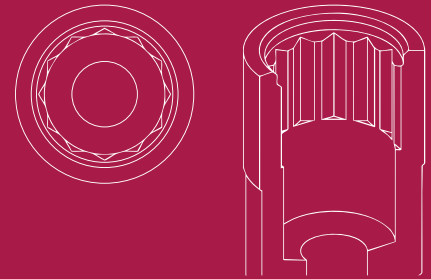

## STANDARD DYNAMIC TIBASE

GH (mm)	$\alpha_s$	$\alpha_c$	NON ENGAGING	ENGAGING
0,3	43°	29°	31.322.001.01-2	31.312.001.01-2
1,2	25°	22°	31.322.001.02-2	31.312.001.02-2
2	25°	-	31.322.001.03-2	31.312.001.03-2
3	20°	-	31.322.001.04-2	31.312.001.04-2



## DYNAMIC 3TIBASE

GH (mm)	$\alpha_s$ CH=5mm	$\alpha_s$ CH=7mm	$\alpha_s$ CH=9mm	NON ENGAGING	ENGAGING
0,3	25°	20°	10°	31.322.001.21-2	31.312.001.21-2
2	25°	20°	10°	-	31.312.001.23-2



## DYNAMIC SCANBODY (LAB/CLIN)

H (mm)	SCANBODY	ADAPTOR	SCREWDRIVER ADAPTOR
10	52.410.103.01-2	50.312.001.01-2	43.621.410.01-2
12	52.412.103.01-2	50.312.001.04-2 (IG=3mm)	43.624.410.01-2



LAB SCANBODY	SCANALOG
30.412.001.01-2	23.412.001.01-2



LIBRARY OPTIONS: GH = Gingival Height CH = Cement Height H = Height IG = Adaptor 3mm  $\alpha_s$  = Standard maximum angulation  $\alpha_c$  = Standard maximum angulation  $\alpha_d$  = Direct to implant maximum angulation

**DYNAMIC MILLING TOOL**

**ANALOG**

SHANK	$\alpha_{di}$	DYNAMIC MILLING TOOL	ANALOG	DIGITAL ANALOG
3		33.390.754.01-2	22.612.001.01-2	34.612.001.01-2
4	25°	33.490.754.01-2		
6		33.690.754.01-2		



**SCANBODY OP**

SCANBODY	PEEK PINS	HEIGHT	TYPE	SCREWDRIVER
54.315.001.21-2	49.414.000.01-2	6	A	43.601.103.02-2
	49.415.000.01-2	9	A	
	49.416.000.01-2	13	A	
	49.414.000.02-2	6	B	
	49.415.000.02-2	9	B	
	49.416.000.02-2	13	B	
	49.414.000.03-2	6	C	
	49.415.000.03-2	9	C	
	49.416.000.03-2	13	C	
	49.416.000.04-2	13	D	
	49.416.000.05-2	13	E	



**SCREWS**

DYNAMIC SCREW	LENGTH	SCREWDRIVER
41.316.084.01-2	18	43.618.201.01-2
	24	43.624.201.01-2
	32	43.632.201.01-2



LIBRARY OPTIONS: GH = Gingival Height CH = Cement Height H = Height IG = Adaptor 3mm  $\alpha_s$  = Standard maximum angulation  $\alpha_d$  = Standard maximum angulation  $\alpha_i$  = Direct to implant maximum angulation

STRAIGHT SCREW	TYPE	SCREWDRIVER
40.316.003.01-2	Hex. 1.20	43.601.103.02-2



## MULTI-UNIT

### STRAIGHT MULTI-UNIT

GH (mm)	NON ENGAGING
1	42.302.001.01-2
2	42.302.001.02-2
3	42.302.001.03-2
4	42.302.001.04-2



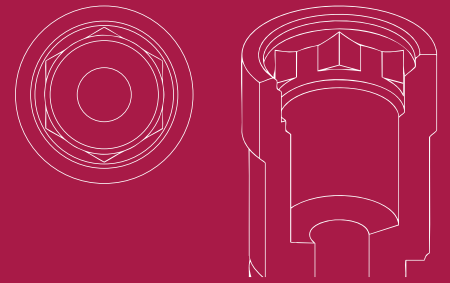

# COMPATIBLE WITH 0002

LIST OF COMPATIBILITIES **AVAILABLE**  
BIOMET 3L

## STANDARD DYNAMIC TIBASE

GH (mm)	$\alpha_s$	$\alpha_c$	NON ENGAGING	ENGAGING
0,3	45°	29°	31.323.002.01-2	31.313.002.01-2
1,2	25°	22°	31.323.002.02-2	31.313.002.02-2



## DYNAMIC 3TIBASE

GH (mm)	$\alpha_s$ CH=5mm	$\alpha_s$ CH=7mm	$\alpha_s$ CH=9mm	NON ENGAGING	ENGAGING
0,3	25°	20°	10°	31.323.002.21-2	31.313.002.21-2



## DYNAMIC SCANBODY (LAB/CLIN)

H (mm)	SCANBODY	ADAPTOR	SCREWDRIVER ADAPTOR
8	52.408.101.01-2		
10	52.410.101.01-2	50.313.002.01-2	43.621.410.01-2 43.624.410.01-2
12	52.412.101.01-2		



LAB SCANBODY	SCANALOG
30.413.002.01-2	23.413.002.01-2



LIBRARY OPTIONS: GH = Gingival Height CH = Cement Height H = Height IG = Adaptor 3mm  $\alpha_s$  = Standard maximum angulation  $\alpha_c$  = Standard maximum angulation  $\alpha_d$  = Direct to implant maximum angulation

## DYNAMIC MILLING TOOL

## ANALOG

SHANK	$\alpha_{di}$	DYNAMIC MILLING TOOL	ANALOG	DIGITAL ANALOG
3		33.390.805.01-2	22.613.002.01-2	34.613.002.01-2
4	30°	33.490.805.01-2		
6		33.690.805.01-2		



## SCANBODY OP

SCANBODY	PEEK PINS	HEIGHT	TYPE	SCREWDRIVER
54.315.002.21-2	49.414.000.01-2	6	A	43.601.103.02-2
	49.415.000.01-2	9	A	
	49.416.000.01-2	13	A	
	49.414.000.02-2	6	B	
	49.415.000.02-2	9	B	
	49.416.000.02-2	13	B	
	49.414.000.03-2	6	C	
	49.415.000.03-2	9	C	
	49.416.000.03-2	13	C	
	49.416.000.04-2	13	D	
49.416.000.05-2	13	E		



## SCREWS

DYNAMIC SCREW	LENGTH	SCREWDRIVER
41.316.084.01-2	18	43.618.201.01-2
	24	43.624.201.01-2
	32	43.632.201.01-2



STRAIGHT SCREW	TYPE	SCREWDRIVER
40.316.003.01-2	Hex. 1.20	43.601.103.02-2



## MULTI-UNIT

### STRAIGHT MULTI-UNIT

GH (mm)	NON ENGAGING
1	42.303.002.01-2
2	42.303.002.02-2
3	42.303.002.03-2
4	42.303.002.04-2



# COMPATIBLE WITH 0003

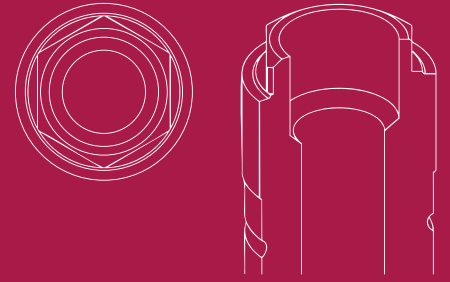

## LIST OF COMPATIBILITIES AVAILABLE

BIOMET 3L - BIOLOK - BTK - EASY IMPLANT - MICRODENT - MOZO-GRAU (TICARE) - SOUTHERN IMPLANTS

### STANDARD DYNAMIC TIBASE

GH (mm)	$\alpha_s$	$\alpha_c$	NON ENGAGING	ENGAGING
0,3	45°	30°	31.322.003.01-2	31.312.003.01-2
0,5	25°	30°	31.322.003.02-2	31.312.003.02-2



### DYNAMIC 3TIBASE

GH (mm)	$\alpha_s$ CH=5mm	$\alpha_s$ CH=7mm	$\alpha_s$ CH=9mm	NON ENGAGING	ENGAGING
1	30°	25°	15°	31.322.003.23-2	31.312.003.23-2



### DYNAMIC SCANBODY (LAB/CLIN)

H (mm)	SCANBODY	ADAPTOR	SCREWDRIVER ADAPTOR
10	52.410.104.01-2	50.312.003.01-2	43.621.410.01-2
12	52.412.104.01-2		43.624.410.01-2



LAB SCANBODY
30.412.001.01-2



LIBRARY OPTIONS: GH = Gingival Height CH = Cement Height H = Height IG = Adaptor 3mm  $\alpha_s$  = Standard maximum angulation  $\alpha_c$  = Standard maximum angulation  $\alpha_d$  = Direct to implant maximum angulation

## DYNAMIC MILLING TOOL

## ANALOG

SHANK	$\alpha_{di}$	DYNAMIC MILLING TOOL	ANALOG	DIGITAL ANALOG
3		33.390.716.01-2	22.612.003.01-2	34.612.003.01-2
4	25°	33.490.716.01-2		
6		33.690.716.01-2		



## SCREWS

DYNAMIC SCREW	LENGTH	SCREWDRIVER
	18	43.618.201.01-2
41.320.065.01-2	24	43.624.201.01-2
	32	43.632.201.01-2



STRAIGHT SCREW	TYPE	SCREWDRIVER
40.320.003.02-2	Hex. 1.20	43.601.103.02-2



# COMPATIBLE WITH 0004

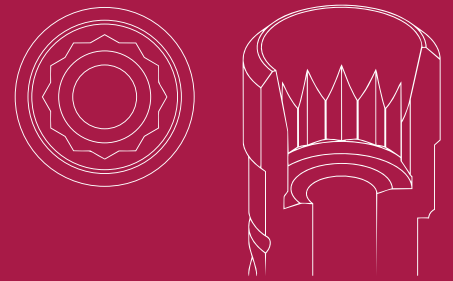

## LIST OF COMPATIBILITIES AVAILABLE

ASTRA - CORTEX - EASY IMPLANTS - EUROTEKNIKA - GALIMPLANT - IMPLANTSWISS - MOZO-GRAU (TICARE) - MPI - PROCLINIC  
REFLECT - SIGNO VINCES - SOUTHERN IMPLANTS - TITANIUM-FIX - UFIT - WARANTEC (ONEPLANT) - ZIACOM

### STANDARD DYNAMIC TIBASE

GH (mm)	$\alpha_s$	$\alpha_c$	NON ENGAGING	ENGAGING
1	45°	29°	31.323.004.01-2	31.313.004.01-2
2	30°	20°	31.323.004.02-2	31.313.004.02-2
3	25°	25°	31.323.004.03-2	31.313.004.03-2
4	20°	25°	31.323.004.04-2	31.313.004.04-2



### DYNAMIC 3TIBASE

GH (mm)	$\alpha_s$ CH=5mm	$\alpha_s$ CH=7mm	$\alpha_s$ CH=9mm	NON ENGAGING	ENGAGING
1	25°	20°	10°	31.323.004.21-2	31.313.004.21-2



### DYNAMIC SCANBODY (LAB/CLIN)

H (mm)	SCANBODY	ADAPTOR	SCREWDRIVER ADAPTOR
10	52.410.103.01-2	50.313.004.01-2	43.621.410.01-2
12	52.412.103.01-2	50.313.004.03-2 (IG=3mm)	43.624.410.01-2



LAB SCANBODY	SCANALOG
30.413.002.01-2	23.413.004.02-2



LIBRARY OPTIONS: GH = Gingival Height CH = Cement Height H = Height IG = Adaptor 3mm  $\alpha_s$  = Standard maximum angulation  $\alpha_c$  = Standard maximum angulation  $\alpha_d$  = Direct to implant maximum angulation

## DYNAMIC MILLING TOOL

## ANALOG

SHANK	$\alpha_{di}$	DYNAMIC MILLING TOOL	ANALOG	DIGITAL ANALOG
3		33.390.754.01-2	22.613.004.01-2	34.613.004.01-2
4	25°	33.490.754.01-2		
6		33.690.754.01-2		



## SCANBODY OP

SCANBODY	PEEK PINS	HEIGHT	TYPE	SCREWDRIVER
54.315.004.21-2	49.414.000.01-2	6	A	43.625.105.01-2
	49.415.000.01-2	9	A	
	49.416.000.01-2	13	A	
	49.414.000.02-2	6	B	
	49.415.000.02-2	9	B	
	49.416.000.02-2	13	B	
	49.414.000.03-2	6	C	
	49.415.000.03-2	9	C	
	49.416.000.03-2	13	C	
	49.416.000.04-2	13	D	
49.416.000.05-2	13	E		



## SCREWS

DYNAMIC SCREW	HIGH	LENGTH	SCREWDRIVER
41.316.076.01-2	41.316.118.01-2	18	43.618.201.01-2
		24	43.624.201.01-2
		32	43.632.201.01-2



STRAIGHT SCREW	TYPE	SCREWDRIVER
40.316.005.02-2	Hex. 1.27	43.625.105.01-2



## MULTI-UNIT

### STRAIGHT MULTI-UNIT

GH (mm)	NON ENGAGING
1	42.303.004.01-2
2	42.303.004.02-2
3	42.303.004.03-2
4	42.303.004.04-2



### ANGULATED MULTI-UNIT 20°

GH (mm)	ENGAGING
2.5/3.9	48.312.004.02-2
3.5/4.9	48.312.004.03-2
4.5/5.9	48.312.004.04-2



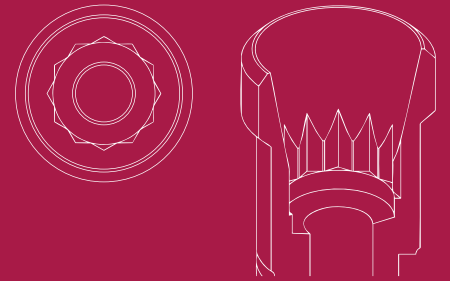

# COMPATIBLE WITH 0005

## LIST OF COMPATIBILITIES AVAILABLE

ASTRA - BIOGENESIS - CORTEX - GT MEDICAL - MOZO-GRAU (TICARE) - MPI - REFLECT - SIGNO VINCES - PROCLINIC  
SOUTHERN IMPLANTS - TITANIUM-FIX - UFIT

### STANDARD DYNAMIC TIBASE

GH (mm)	$\alpha_s$	$\alpha_c$	NON ENGAGING	ENGAGING
1	38°	23°	31.324.005.01-2	31.314.005.01-2
2	25°	15°	31.324.005.02-2	31.314.005.02-2
3	20°	-	31.324.005.03-2	31.314.005.03-2
4	15°	-	31.324.005.04-2	31.314.005.04-2



### DYNAMIC 3TIBASE

GH (mm)	$\alpha_s$ CH=5mm	$\alpha_s$ CH=7mm	$\alpha_s$ CH=9mm	NON ENGAGING	ENGAGING
1	25°	20°	10°	31.324.005.21-2	31.314.005.21-2



### DYNAMIC SCANBODY (LAB/CLIN)

H (mm)	SCANBODY	ADAPTOR	SCREWDRIVER ADAPTOR
10	52.410.102.01-2	50.314.005.01-2	43.621.410.01-2
12	52.412.102.01-2	50.314.005.03-2 (IG=3mm)	43.624.410.01-2



#### LAB SCANBODY

30.413.002.01-2



LIBRARY OPTIONS: GH = Gingival Height CH = Cement Height H = Height IG = Adaptor 3mm  $\alpha_s$  = Standard maximum angulation  $\alpha_c$  = Standard maximum angulation  $\alpha_d$  = Direct to implant maximum angulation

**DYNAMIC MILLING TOOL**

**ANALOG**

SHANK	$\alpha_{di}$	DYNAMIC MILLING TOOL	ANALOG	DIGITAL ANALOG
3		33.390.958.01-2	22.614.005.01-2	34.614.005.01-2
4	30°	33.490.958.01-2		
6		33.690.958.01-2		



**SCANBODY OP**

SCANBODY	PEEK PINS	HEIGHT	TYPE	SCREWDRIVER
	49.414.000.01-2	6	A	
	49.415.000.01-2	9	A	
	49.416.000.01-2	13	A	
	49.414.000.02-2	6	B	
	49.415.000.02-2	9	B	
54.315.005.21-2	49.416.000.02-2	13	B	43.625.105.01-2
	49.414.000.03-2	6	C	
	49.415.000.03-2	9	C	
	49.416.000.03-2	13	C	
	49.416.000.04-2	13	D	
	49.416.000.05-2	13	E	



**SCREWS**

DYNAMIC SCREW	HIGH	LENGTH	SCREWDRIVER
		18	43.618.201.01-2
41.320.090.01-2	41.320.137.01-2	24	43.624.201.01-2
		32	43.632.201.01-2



STRAIGHT SCREW	TYPE	SCREWDRIVER
40.320.005.03-2	Hex. 1.27	43.625.105.01-2



LIBRARY OPTIONS: GH = Gingival Height CH = Cement Height H = Height IG = Adaptor 3mm  $\alpha_s$  = Standard maximum angulation  $\alpha_d$  = Standard maximum angulation  $\alpha_i$  = Direct to implant maximum angulation

# COMPATIBLE WITH 0006

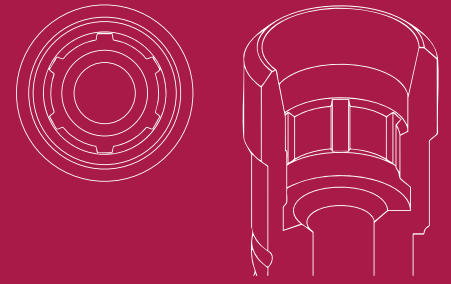

## LIST OF COMPATIBILITIES AVAILABLE

ASTRA

### STANDARD DYNAMIC TIBASE

GH (mm)	$\alpha_s$	$\alpha_c$	NON ENGAGING	ENGAGING
1,2	40°	20°	31.322.006.01-2	31.312.006.01-2
2	25°	12°	31.322.006.02-2	31.312.006.02-2
3	20°	30°	31.322.006.03-2	31.312.006.03-2
4	15°	30°	31.322.006.04-2	31.312.006.04-2



### DYNAMIC 3TIBASE

GH (mm)	$\alpha_s$ CH=5mm	$\alpha_s$ CH=7mm	$\alpha_s$ CH=9mm	NON ENGAGING	ENGAGING
1,2	30°	20°	15°	31.322.006.21-2	31.312.006.21-2



### DYNAMIC SCANBODY (LAB/CLIN)

H (mm)	SCANBODY	ADAPTOR	SCREWDRIVER ADAPTOR
10	52.410.105.01-2	50.312.006.03-2 (IG=3mm)	43.621.410.01-2
12	52.412.105.01-2		43.624.410.01-2



LAB SCANBODY	SCANALOG
30.412.001.01-2	23.412.006.01-2



LIBRARY OPTIONS: GH = Gingival Height CH = Cement Height H = Height IG = Adaptor 3mm  $\alpha_s$  = Standard maximum angulation  $\alpha_c$  = Standard maximum angulation  $\alpha_d$  = Direct to implant maximum angulation

## DYNAMIC MILLING TOOL

## ANALOG

SHANK	$\alpha_{di}$	DYNAMIC MILLING TOOL	ANALOG	DIGITAL ANALOG
3		33.330.734.01-2	22.612.006.01-2	34.612.006.01-2
4	25°	33.430.734.01-2		
6		33.630.734.01-2		



## SCANBODY OP

SCANBODY	PEEK PINS	HEIGHT	TYPE	SCREWDRIVER
	49.414.000.01-2	6	A	
	49.415.000.01-2	9	A	
	49.416.000.01-2	13	A	
	49.414.000.02-2	6	B	
	49.415.000.02-2	9	B	
54.315.006.21-2	49.416.000.02-2	13	B	43.625.105.01-2
	49.414.000.03-2	6	C	
	49.415.000.03-2	9	C	
	49.416.000.03-2	13	C	
	49.416.000.04-2	13	D	
	49.416.000.05-2	13	E	



## SCREWS

DYNAMIC SCREW	HIGH	LENGTH	SCREWDRIVER
		18	43.618.201.01-2
41.316.072.01-2	41.316.115.01-2	24	43.624.201.01-2
		32	43.632.201.01-2



STRAIGHT SCREW	TYPE	SCREWDRIVER
40.316.005.01-2	Hex. 1.27	43.625.105.01-2



## MULTI-UNIT

### STRAIGHT MULTI-UNIT

GH (mm)	NON ENGAGING
1	42.302.006.01-2
2	42.302.006.02-2
3	42.302.006.03-2
4	42.302.006.04-2



### ANGULATED MULTI-UNIT 20°

GH (mm)	ENGAGING
2.5/3.9	48.312.006.02-2
3.5/4.9	48.312.006.03-2
4.5/5.9	48.312.006.04-2



# COMPATIBLE WITH 0007

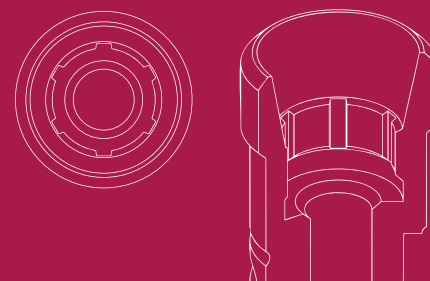

## LIST OF COMPATIBILITIES AVAILABLE

ASTRA

### STANDARD DYNAMIC TIBASE

GH (mm)	$\alpha_s$	$\alpha_c$	NON ENGAGING	ENGAGING
1.5	38°	17°	31.323.007.01-2	31.313.007.01-2
2	25°	12°	31.323.007.02-2	31.313.007.02-2
3	25°	-	31.323.007.03-2	31.313.007.03-2



### DYNAMIC 3TIBASE

GH (mm)	$\alpha_s$ CH=5mm	$\alpha_s$ CH=7mm	$\alpha_s$ CH=9mm	NON ENGAGING	ENGAGING
1.5	25°	20°	10°	31.323.007.21-2	31.313.007.21-2



### DYNAMIC SCANBODY (LAB/CLIN)

H (mm)	SCANBODY	ADAPTOR	SCREWDRIVER ADAPTOR
8	52.408.101.01-2		
10	52.410.101.01-2	50.313.007.01-2 50.313.007.03-2 (IG=3mm)	43.621.410.01-2 43.624.410.01-2
12	52.412.101.01-2		



LAB SCANBODY	SCANALOG
30.413.002.01-2	23.413.007.01-2



LIBRARY OPTIONS: GH = Gingival Height CH = Cement Height H = Height IG = Adaptor 3mm  $\alpha_s$  = Standard maximum angulation  $\alpha_c$  = Standard maximum angulation  $\alpha_d$  = Direct to implant maximum angulation

## DYNAMIC MILLING TOOL

## ANALOG

SHANK	$\alpha_{di}$	DYNAMIC MILLING TOOL	ANALOG	DIGITAL ANALOG
3		33.350.775.01-2	22.613.007.01-2	34.613.007.01-2
4	25°	33.450.775.01-2		
6		33.650.775.01-2		



## SCANBODY OP

SCANBODY	PEEK PINS	HEIGHT	TYPE	SCREWDRIVER
54.315.007.21-2	49.414.000.01-2	6	A	43.625.105.01-2
	49.415.000.01-2	9	A	
	49.416.000.01-2	13	A	
	49.414.000.02-2	6	B	
	49.415.000.02-2	9	B	
	49.416.000.02-2	13	B	
	49.414.000.03-2	6	C	
	49.415.000.03-2	9	C	
	49.416.000.03-2	13	C	
	49.416.000.04-2	13	D	
49.416.000.05-2	13	E		



## SCREWS

DYNAMIC SCREW	LENGTH	SCREWDRIVER
41.318.074.01-2	18	43.618.201.01-2
	24	43.624.201.01-2
	32	43.632.201.01-2



STRAIGHT SCREW	TYPE	SCREWDRIVER
40.318.005.02-2	Hex. 1.27	43.625.105.01-2



## MULTI-UNIT

### STRAIGHT MULTI-UNIT

GH (mm)	NON ENGAGING
1	42.303.007.01-2
2	42.303.007.02-2
3	42.303.007.03-2
4	42.303.007.04-2



### ANGULATED MULTI-UNIT 20°

GH (mm)	ENGAGING
1,5/2,9	48.312.007.01-2
2,5/3,9	48.312.007.02-2
4,5/5,9	48.312.007.03-2



# COMPATIBLE WITH 0008

## LIST OF COMPATIBILITIES AVAILABLE

ASTRA

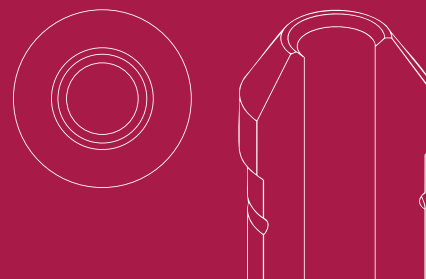

### STANDARD DYNAMIC TIBASE

GH (mm)	$\alpha_s$	$\alpha_c$	NON ENGAGING	ENGAGING
0,5	45°	30°	31.323.008.01-2	-



### DYNAMIC 3TIBASE

GH (mm)	$\alpha_s$ CH=5mm	$\alpha_s$ CH=7mm	$\alpha_s$ CH=9mm	NON ENGAGING	ENGAGING
0,5	25°	20°	10°	31.323.008.21-2	-



### DYNAMIC SCANBODY (LAB/CLIN)

H (mm)	SCANBODY	ADAPTOR	SCREWDRIVER ADAPTOR
8	52.408.113.01-2	50.313.008.01-2	43.621.410.01-2 43.624.410.01-2



LAB SCANBODY	SCANALOG
30.412.001.01-2	23.413.008.01-2



### DYNAMIC MILLING TOOL

SHANK	$\alpha_{di}$	DYNAMIC MILLING TOOL	DIGITAL ANALOG
3		33.370.716.01-2	34.613.008.01-2
4	30°	33.470.716.01-2	
6		33.670.716.01-2	

### ANALOG



LIBRARY OPTIONS: GH = Gingival Height CH = Cement Height H = Height IG = Adaptor 3mm  $\alpha_s$  = Standard maximum angulation  $\alpha_c$  = Standard maximum angulation  $\alpha_{di}$  = Direct to implant maximum angulation

## SCANBODY OP

SCANBODY	PEEK PINS	HEIGHT	TYPE	SCREWDRIVER
54.322.008.31-2	49.414.000.01-2	6	A	43.625.105.01-2
	49.415.000.01-2	9	A	
	49.416.000.01-2	13	A	
	49.414.000.02-2	6	B	
	49.415.000.02-2	9	B	
	49.416.000.02-2	13	B	
	49.414.000.03-2	6	C	
	49.415.000.03-2	9	C	
	49.416.000.03-2	13	C	
	49.416.000.04-2	13	D	
49.416.000.05-2	13	E		
	CAPS	HEIGHT	TYPE	
	49.418.000.01-2	3,8	Regular	
	49.418.000.02-2	3,8	Wide	
	49.419.000.01-2	6	Regular	
	49.419.000.02-2	6	Wide	
	49.420.000.01-2	8	Regular	
	49.420.000.02-2	8	Wide	



## SCREWS

DYNAMIC SCREW	LENTH	SCREWDRIVER
41.318.045.01-2	18	43.618.201.01-2
	24	43.624.201.01-2
	32	43.632.201.01-2
STRAIGHT SCREW	TYPE	SCREWDRIVER
40.318.005.01-2	Hex. 1.27	43.625.105.01-2



LIBRARY OPTIONS: GH = Gingival Height CH = Cement Height H = Height IG = Adaptor 3mm Gs = Standard maximum angulation Gc = Standard maximum angulation Gd = Direct to implant maximum angulation

# COMPATIBLE WITH 0009

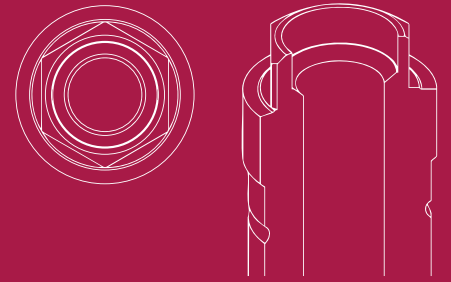

## LIST OF COMPATIBILITIES AVAILABLE

BTI - MPI - OSTEOPLUS - PROCLINIC

### STANDARD DYNAMIC TIBASE

GH (mm)	$\alpha_s$	$\alpha_c$	NON ENGAGING	ENGAGING
0,3	45°	25°	31.322.009.01-2	31.312.009.01-2
0,5	25°	25°	31.322.009.02-2	31.312.009.02-2
1	25°	-	31.322.009.03-2	31.312.009.03-2



### DYNAMIC SCANBODY (LAB/CLIN)

H (mm)	SCANBODY	ADAPTOR	SCREWDRIVER ADAPTOR
10	52.410.114.01-2	50.312.009.01-2	43.621.410.01-2
12	52.412.114.01-2		43.624.410.01-2



#### LAB SCANBODY

30.412.001.01-2



### DYNAMIC MILLING TOOL

SHANK	$\alpha_{di}$	DYNAMIC MILLING TOOL	ANALOG	DIGITAL ANALOG
3		33.390.716.01-2	22.612.009.01-2	34.612.009.01-2
4	25°	33.490.716.01-2		
6		33.690.716.01-2		



### ANALOG

LIBRARY OPTIONS: GH = Gingival Height CH = Cement Height H = Height IG = Adaptor 3mm  $\alpha_s$  = Standard maximum angulation  $\alpha_c$  = Standard maximum angulation  $\alpha_{di}$  = Direct to implant maximum angulation

## SCREWS

DYNAMIC SCREW	LENGTH	SCREWDRIVER
	18	43.618.201.01-2
41.320.051.01-2	24	43.624.201.01-2
	32	43.632.201.01-2



STRAIGHT SCREW	TYPE	SCREWDRIVER
40.320.003.01-2	Hex. 1.20	43.601.103.02-2



# COMPATIBLE WITH OO10

## LIST OF COMPATIBILITIES AVAILABLE

BTI

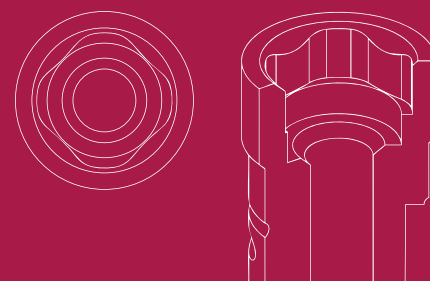

### STANDARD DYNAMIC TIBASE

GH (mm)	$\alpha_s$	$\alpha_c$	NON ENGAGING	ENGAGING
0,3	45°	29°	31.323.010.01-2	31.313.010.01-2



### DYNAMIC SCANBODY (LAB/CLIN)

H (mm)	SCANBODY	ADAPTOR	SCREWDRIVER ADAPTOR
10	52.410.115.01-2	50.313.010.01-2	43.621.410.01-2
12	52.412.115.01-2	50.313.010.04-2 (IG=3mm)	43.624.410.012



#### LAB SCANBODY

30.413.002.01-2



### DYNAMIC MILLING TOOL

SHANK	$\alpha_{di}$	DYNAMIC MILLING TOOL	ANALOG	DIGITAL ANALOG
3		33.390.716.01-2	22.613.010.01-2	34.613.010.01-2
4	30°	33.490.716.01-2		
6		33.690.716.01-2		



### ANALOG

LIBRARY OPTIONS: GH = Gingival Height CH = Cement Height H = Height IG = Adaptor 3mm  $\alpha_s$  = Standard maximum angulation  $\alpha_c$  = Standard maximum angulation  $\alpha_{di}$  = Direct to implant maximum angulation

## SCREWS

DYNAMIC SCREW	LENGTH	SCREWDRIVER
	18	43.618.201.01-2
41.318.065.01-2	24	43.624.201.01-2
	32	43.632.201.01-2



STRAIGHT SCREW	TYPE	SCREWDRIVER
40.318.003.01-2	Hex. 1.20	43.601.103.02-2



## MULTI-UNIT

### STRAIGHT MULTI-UNIT

GH (mm)	NON ENGAGING
1	42.303.010.01-2
2	42.303.010.02-2
3	42.303.010.03-2
4	42.303.010.04-2



# COMPATIBLE WITH 0011

## LIST OF COMPATIBILITIES AVAILABLE

CAMLOG

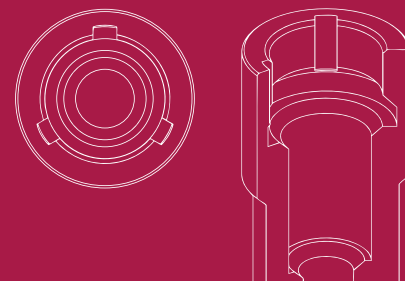

### STANDARD DYNAMIC TIBASE

GH (mm)	$\alpha_s$	$\alpha_c$	NON ENGAGING	ENGAGING
0,3	25°	29°	31.322.011.01-2	31.312.011.01-2



### DYNAMIC 3TIBASE

GH (mm)	$\alpha_s$ CH=5mm	$\alpha_s$ CH=7mm	$\alpha_s$ CH=9mm	NON ENGAGING	ENGAGING
0,3	25°	25°	15°	-	31.312.011.21-2
2	25°	20°	15°	-	31.312.011.23-2
3	25°	20°	10°	-	31.312.011.24-2



### DYNAMIC SCANBODY (LAB/CLIN)

H (mm)	SCANBODY	ADAPTOR	SCREWDRIVER ADAPTOR
10	52.410.108.01-2	50.312.011.01-2	43.621.410.01-2
12	52.412.108.01-2		43.624.410.01-2



#### LAB SCANBODY

30.412.001.01-2



LIBRARY OPTIONS: GH = Gingival Height CH = Cement Height H = Height IG = Adaptor 3mm  $\alpha_s$  = Standard maximum angulation  $\alpha_c$  = Standard maximum angulation  $\alpha_d$  = Direct to implant maximum angulation

## DYNAMIC MILLING TOOL

## ANALOG

SHANK	$\alpha_{di}$	DYNAMIC MILLING TOOL	DIGITAL ANALOG
3		33.345.804.01-2	34.612.011.01-2
4	20°	33.445.804.01-2	
6		33.645.804.01-2	



## SCANBODY OP

SCANBODY	PEEK PINS	HEIGHT	TYPE	SCREWDRIVER
54.315.011.21-2	49.414.000.01-2	6	A	43.625.105.01-2
	49.415.000.01-2	9	A	
	49.416.000.01-2	13	A	
	49.414.000.02-2	6	B	
	49.415.000.02-2	9	B	
	49.416.000.02-2	13	B	
	49.414.000.03-2	6	C	
	49.415.000.03-2	9	C	
	49.416.000.03-2	13	C	
	49.416.000.04-2	13	D	
49.416.000.05-2	13	E		



## SCREWS

DYNAMIC SCREW	LENGTH	SCREWDRIVER
41.316.094.01-2	18	43.618.201.01-2
	24	43.624.201.01-2
	32	43.632.201.01-2



STRAIGHT SCREW	TYPE	SCREWDRIVER
40.316.005.04-2	Hex. 1.27	43.625.105.01-2



## MULTI-UNIT

### STRAIGHT MULTI-UNIT

GH (mm)	NON ENGAGING
1	42.302.011.01-2
2	42.302.011.02-2
3	42.302.011.03-2



# COMPATIBLE WITH OO12

LIST OF COMPATIBILITIES **AVAILABLE**  
CAMLOG

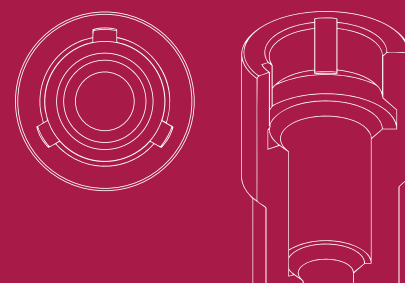

## STANDARD DYNAMIC TIBASE

GH (mm)	$\alpha_s$	$\alpha_c$	NON ENGAGING	ENGAGING
0,3	25°	30°	31.323.012.01-2	31.313.012.01-2



## DYNAMIC 3TIBASE

GH (mm)	$\alpha_s$ CH-5mm	$\alpha_s$ CH-7mm	$\alpha_s$ CH-9mm	NON ENGAGING	ENGAGING
0,3	25°	25°	15°	-	31.313.012.21-2
2	25°	20°	15°	-	31.313.012.23-2
3	25°	20°	10°	-	31.313.012.24-2



## DYNAMIC SCANBODY (LAB/CLIN)

H (mm)	SCANBODY	ADAPTOR	SCREWDRIVER ADAPTOR
10	52.410.109.01-2	50.313.012.01-2	43.621.410.01-2
12	52.412.109.01-2		43.624.410.01-2



### LAB SCANBODY

30.413.002.01-2



LIBRARY OPTIONS: GH = Gingival Height CH = Cement Height H = Height IG = Adaptor 3mm  $\alpha_s$  = Standard maximum angulation  $\alpha_c$  = Standard maximum angulation  $\alpha_d$  = Direct to implant maximum angulation

## DYNAMIC MILLING TOOL

## ANALOG

SHANK	$\alpha_{di}$	DYNAMIC MILLING TOOL	DIGITAL ANALOG
3		33.345.804.01-2	34.613.012.01-2
4	20°	33.445.804.01-2	
6		33.645.804.01-2	



## SCANBODY OP

SCANBODY	PEEK PINS	HEIGHT	TYPE	SCREWDRIVER
54.315.012.21-2	49.414.000.01-2	6	A	43.625.105.01-2
	49.415.000.01-2	9	A	
	49.416.000.01-2	13	A	
	49.414.000.02-2	6	B	
	49.415.000.02-2	9	B	
	49.416.000.02-2	13	B	
	49.414.000.03-2	6	C	
	49.415.000.03-2	9	C	
	49.416.000.03-2	13	C	
	49.416.000.04-2	13	D	
49.416.000.05-2	13	E		



## SCREWS

DYNAMIC SCREW	LENGTH	SCREWDRIVER
41.316.094.01-2	18	43.618.201.01-2
	24	43.624.201.01-2
	32	43.632.201.01-2



STRAIGHT SCREW	TYPE	SCREWDRIVER
40.316.005.04-2	Hex. 1.27	43.625.105.01-2



## MULTI-UNIT

### STRAIGHT MULTI-UNIT

GH (mm)	NON ENGAGING
1	42.303.012.01-2
2	42.303.012.02-2
3	42.303.012.03-2



# COMPATIBLE WITH OO13

LIST OF COMPATIBILITIES **AVAILABLE**  
DIO IMPLANTS

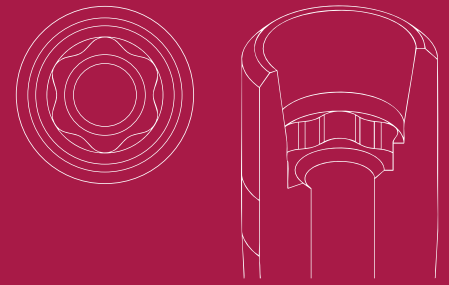

## STANDARD DYNAMIC TIBASE

GH (mm)	$\alpha_s$	$\alpha_c$	NON ENGAGING	ENGAGING
0,7	43°	23°	31.323.013.01-2	31.313.013.01-2
<b>LAB SCANBODY</b>				
30.413.002.01-2				



## SCREWS

DYNAMIC SCREW	LENGTH	SCREWDRIVER
41.320.074.01-2	18	43.618.201.01-2
	24	43.624.201.01-2
	32	43.632.201.01-2



STRAIGHT SCREW	TYPE	SCREWDRIVER
40.320.007.02-2	TORX T6	43.601.107.01-2



LIBRARY OPTIONS: GH = Gingival Height CH = Cement Height H = Height IG = Adaptor 3mm  $\alpha_s$  = Standard maximum angulation  $\alpha_c$  = Standard maximum angulation  $\alpha_d$  = Direct to implant maximum angulation

# COMPATIBLE WITH OO14

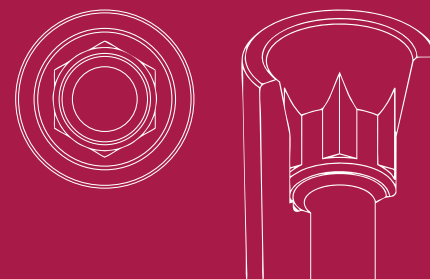

## LIST OF COMPATIBILITIES AVAILABLE

DENTIS - DIO IMPLANT - MEGAGEN

### STANDARD DYNAMIC TIBASE

GH (mm)	$\alpha_s$	$\alpha_c$	NON ENGAGING	ENGAGING
1,2	41°	23°	31.322.014.01-2	31.312.014.01-2
2	25°	17°	31.322.014.02-2	31.312.014.02-2
3	20°	25°	-	31.312.014.03-2



### DYNAMIC 3TIBASE

GH (mm)	$\alpha_s$ CH=5mm	$\alpha_s$ CH=7mm	$\alpha_s$ CH=9mm	NON ENGAGING	ENGAGING
3	25°	20°	15°	31.322.014.23-2	31.312.014.23-2



### DYNAMIC SCANBODY (LAB/CLIN)

H (mm)	SCANBODY	ADAPTOR	SCREWDRIVER ADAPTOR
10	52.410.128.01-2	50.312.014.03-2 (IG=3mm)	43.621.415.01-2



LAB SCANBODY	SCANALOG
30.412.001.01-2	23.412.014.01-2



LIBRARY OPTIONS: GH = Gingival Height CH = Cement Height H = Height IG = Adaptor 3mm  $\alpha_s$  = Standard maximum angulation  $\alpha_c$  = Standard maximum angulation  $\alpha_d$  = Direct to implant maximum angulation

**DYNAMIC MILLING TOOL**

**ANALOG**

SHANK	$\alpha_{di}$	DYNAMIC MILLING TOOL	DIGITAL ANALOG
3		33.345.804.01-2	34.612.014.01-2
4	25°	33.445.804.01-2	
6		33.645.804.01-2	



**SCANBODY OP**

SCANBODY	PEEK PINS	HEIGHT	TYPE	SCREWDRIVER
54.315.014.21-2	49.414.000.01-2	6	A	43.601.103.02-2
	49.415.000.01-2	9	A	
	49.416.000.01-2	13	A	
	49.414.000.02-2	6	B	
	49.415.000.02-2	9	B	
	49.416.000.02-2	13	B	
	49.414.000.03-2	6	C	
	49.415.000.03-2	9	C	
	49.416.000.03-2	13	C	
	49.416.000.04-2	13	D	
49.416.000.05-2	13	E		



**SCREWS**

DYNAMIC SCREW	HIGH	LENGTH	SCREWDRIVER
41.314.067.01-2	41.314.105.01-2	18	43.618.201.01-2
		24	43.624.201.01-2
		32	43.632.201.01-2



STRAIGHT SCREW	TYPE	SCREWDRIVER
40.314.003.04-2	Hex. 1.20	43.601.103.02-2



LIBRARY OPTIONS: GH = Gingival Height CH = Cement Height H = Height IG = Adaptor 3mm  $\alpha_s$  = Standard maximum angulation  $\alpha_d$  = Standard maximum angulation  $\alpha_i$  = Direct to implant maximum angulation

## MULTI-UNIT

### STRAIGHT MULTI-UNIT

GH (mm)	NON ENGAGING
2	42.302.014.02-2
3	42.302.014.03-2
4	42.302.014.04-2



### ANGULATED MULTI-UNIT 20°

GH (mm)	ENGAGING
3.5/4.9	48.312.014.03-2
4.5/5.9	48.312.014.04-2



# COMPATIBLE WITH OO15

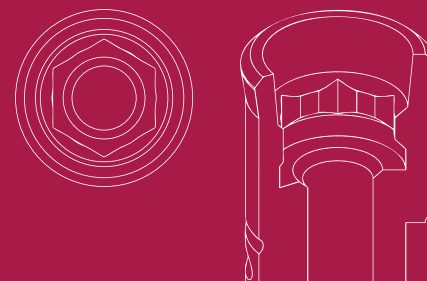

## LIST OF COMPATIBILITIES AVAILABLE

OXY - JDENTALCARE - MEGAGEN

### STANDARD DYNAMIC TIBASE

GH (mm)	$\alpha_s$	$\alpha_c$	NON ENGAGING	ENGAGING
1,7	43°	23°	31.323.015.01-2	31.313.015.01-2
2,5	25°	15°	31.323.015.02-2	31.313.015.02-2
3	25°	-	31.323.015.03-2	31.313.015.03-2
4	20°	-	31.323.015.04-2	31.313.015.04-2
5	15°	-	31.323.015.05-2	31.313.015.05-2



### DYNAMIC 3TIBASE

GH (mm)	$\alpha_s$ CH=5mm	$\alpha_s$ CH=7mm	$\alpha_s$ CH=9mm	NON ENGAGING	ENGAGING
1	30°	25°	20°	31.323.015.27-2	31.313.015.27-2
1,7	30°	25°	10°	31.323.015.21-2	31.313.015.21-2
2,5	25°	20°	10°	31.323.015.22-2	31.313.015.22-2
3,5	25°	20°	10°	-	31.313.015.26-2



### DYNAMIC SCANBODY (LAB/CLIN)

H (mm)	SCANBODY	ADAPTOR	SCREWDRIVER ADAPTOR
10	52.410.104.01-2	50.313.015.01-2	43.621.410.01-2
12	52.412.104.01-2	50.313.015.03-2 (IG=3mm)	43.624.410.01-2



LIBRARY OPTIONS: GH = Gingival Height CH = Cement Height H = Height IG = Adaptor 3mm  $\alpha_s$  = Standard maximum angulation  $\alpha_c$  = Standard maximum angulation  $\alpha_d$  = Direct to implant maximum angulation

LAB SCANBODY	SCANALOG
30.413.002.01-2	23.413.015.01-2



### DYNAMIC MILLING TOOL

### ANALOG

SHANK	$\alpha_{di}$	DYNAMIC MILLING TOOL	DIGITAL ANALOG
3		33.390.805.01-2	34.613.015.01-2
4	25°	33.490.805.01-2	
6		33.690.805.01-2	



### SCANBODY OP

SCANBODY	PEEK PINS	HEIGHT	TYPE	SCREWDRIVER
	49.414.000.01-2	6	A	
	49.415.000.01-2	9	A	
	49.416.000.01-2	13	A	
	49.414.000.02-2	6	B	
	49.415.000.02-2	9	B	
54.315.015.21-2	49.416.000.02-2	13	B	43.601.103.02-2
	49.414.000.03-2	6	C	
	49.415.000.03-2	9	C	
	49.416.000.03-2	13	C	
	49.416.000.04-2	13	D	
	49.416.000.05-2	13	E	



### SCREWS

DYNAMIC SCREW	LENGTH	SCREWDRIVER
	18	43.618.201.01-2
41.318.075.01-2	24	43.624.201.01-2
	32	43.632.201.01-2



STRAIGHT SCREW	TYPE	SCREWDRIVER
40.318.003.02-2	Hex. 1.20	43.601.103.02-2



## MULTI-UNIT

### STRAIGHT MULTI-UNIT

GH (mm)	NON ENGAGING
1	42.303.015.01-2
2	42.303.015.02-2
3	42.303.015.03-2
4	42.303.015.04-2



### ANGULATED MULTI-UNIT 20°

GH (mm)	ENGAGING
1,5/2,9	48.312.015.01-2
2,5/3,9	48.312.015.02-2
4,5/5,9	48.312.015.04-2



### INTERNAL MULTI-UNIT

GH (mm)	ENGAGING
2	62.303.015.02-2
3	62.303.015.03-2
4	62.303.015.04-2



# COMPATIBLE WITH 0016

LIST OF COMPATIBILITIES **AVAILABLE**  
MIS

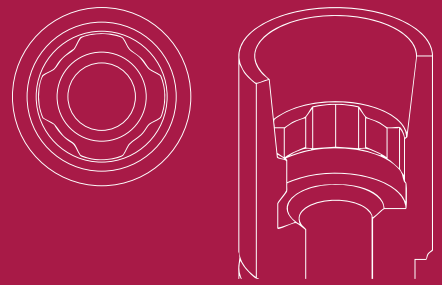

## STANDARD DYNAMIC TIBASE

GH (mm)	$\alpha_s$	$\alpha_c$	NON ENGAGING	ENGAGING
0,8	45°	28°	31.322.016.01-2	31.312.016.01-2
1,5	25°	25°	31.322.016.02-2	31.312.016.02-2



## DYNAMIC 3TIBASE

GH (mm)	$\alpha_s$ CH=5mm	$\alpha_s$ CH=7mm	$\alpha_s$ CH=9mm	NON ENGAGING	ENGAGING
1,5	25°	25°	15°	-	31.312.016.22-2



## DYNAMIC SCANBODY (LAB/CLIN)

H (mm)	SCANBODY	ADAPTOR	SCREWDRIVER ADAPTOR
8	52.408.106.01-2		
10	52.410.106.01-2	50.312.016.01-2 50.312.016.04-2 (IG=3mm)	43.621.410.01-2 43.624.410.01-2
12	52.412.106.01-2		



### LAB SCANBODY

30.412.001.01-2



LIBRARY OPTIONS: GH = Gingival Height CH = Cement Height H = Height IG = Adaptor 3mm  $\alpha_s$  = Standard maximum angulation  $\alpha_c$  = Standard maximum angulation  $\alpha_d$  = Direct to implant maximum angulation

## DYNAMIC MILLING TOOL

## ANALOG

SHANK	$\alpha_{di}$	DYNAMIC MILLING TOOL	DIGITAL ANALOG
3		33.360.754.01-2	34.612.016.01-2
4	25°	33.460.754.01-2	
6		33.660.754.01-2	



## SCREWS

DYNAMIC SCREW	LENGTH	SCREWDRIVER
	18	43.618.201.01-2
41.316.071.01-2	24	43.624.201.01-2
	32	43.632.201.01-2



STRAIGHT SCREW	TYPE	SCREWDRIVER
40.316.005.05-2	Hex. 1.27	43.625.105.01-2



## MULTI-UNIT

### STRAIGHT MULTI-UNIT

GH (mm)	ENGAGING
1	42.302.016.01-2
2	42.302.016.02-2
3	42.302.016.03-2
4	42.302.016.04-2



# COMPATIBLE WITH OO17

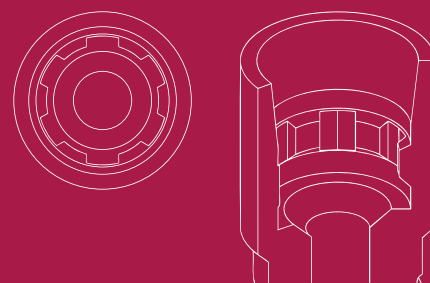

## LIST OF COMPATIBILITIES AVAILABLE MIS

### STANDARD DYNAMIC TIBASE

GH (mm)	$\alpha_s$	$\alpha_c$	NON ENGAGING	ENGAGING
0,7	45°	24°	31.323.017.01-2	31.313.017.01-2
1,5	25°	15°	31.323.017.02-2	31.313.017.02-2



### DYNAMIC 3TIBASE

GH (mm)	$\alpha_s$ CH=5mm	$\alpha_s$ CH=7mm	$\alpha_s$ CH=9mm	NON ENGAGING	ENGAGING
0,7	30°	25°	15°	31.323.017.21-2	31.313.017.21-2



### DYNAMIC SCANBODY (LAB/CLIN)

H (mm)	SCANBODY	ADAPTOR	SCREWDRIVER ADAPTOR
8	52.408.101.01-2		
10	52.410.101.01-2	50.313.017.04-2 (IG=3mm)	43.621.410.01-2 43.624.410.01-2
12	52.412.101.01-2		



LAB SCANBODY
30.413.002.01-2



LIBRARY OPTIONS: GH = Gingival Height CH = Cement Height H = Height IG = Adaptor 3mm  $\alpha_s$  = Standard maximum angulation  $\alpha_c$  = Standard maximum angulation  $\alpha_d$  = Direct to implant maximum angulation

## DYNAMIC MILLING TOOL

## ANALOG

SHANK	$\alpha_{di}$	DYNAMIC MILLING TOOL	DIGITAL ANALOG
3		33.360.756.01-2	34.613.017.01-2
4	30°	33.460.756.01-2	
6		33.660.756.01-2	



## SCREWS

DYNAMIC SCREW	LENGTH	SCREWDRIVER
41.317.073.01-2	18	43.618.201.01-2
	24	43.624.201.01-2
	32	43.632.201.01-2



STRAIGHT SCREW	TYPE	SCREWDRIVER
40.317.005.01-2	Hex. 1.27	43.625.105.01-2



## MULTI-UNIT

### STRAIGHT MULTI-UNIT

GH (mm)	ENGAGING
2	42.303.017.02-2



# COMPATIBLE WITH OO18

LIST OF COMPATIBILITIES **AVAILABLE**  
MIS

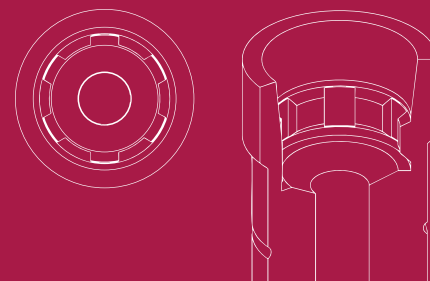

## STANDARD DYNAMIC TIBASE

GH (mm)	$\alpha_s$	$\alpha_c$	NON ENGAGING	ENGAGING
1,2	39°	18°	31.324.018.01-2	31.314.018.01-2



## DYNAMIC SCANBODY (LAB/CLIN)

H (mm)	SCANBODY	ADAPTOR	SCREWDRIVER ADAPTOR
10	52.410.102.01-2	50.314.018.01-2	43.621.410.01-2
12	52.412.102.01-2		43.624.410.01-2



### LAB SCANBODY

30.413.002.01-2



## DYNAMIC MILLING TOOL

SHANK	$\alpha_{di}$	DYNAMIC MILLING TOOL	DIGITAL ANALOG
3		33.360.756.01-2	34.614.018.01-2
4	30°	33.460.756.01-2	
6		33.660.756.01-2	



LIBRARY OPTIONS: GH = Gingival Height CH = Cement Height H = Height IG = Adaptor 3mm  $\alpha_s$  = Standard maximum angulation  $\alpha_c$  = Standard maximum angulation  $\alpha_{di}$  = Direct to implant maximum angulation

## SCREWS

DYNAMIC SCREW	LENGTH	SCREWDRIVER
	18	43.618.201.01-2
41.317.073.01-2	24	43.624.201.01-2
	32	43.632.201.01-2



STRAIGHT SCREW	TYPE	SCREWDRIVER
40.317.005.01-2	Hex. 1.27	43.625.105.01-2



# COMPATIBLE WITH 0019

LIST OF COMPATIBILITIES **AVAILABLE**  
MIS

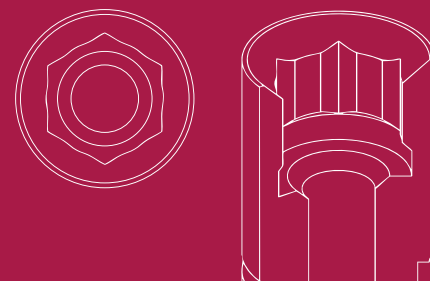

## STANDARD DYNAMIC TIBASE

GH (mm)	$\alpha_s$	$\alpha_c$	NON ENGAGING	ENGAGING
0,8	45°	30°	31.322.019.01-2	31.312.019.01-2



## DYNAMIC SCANBODY (LAB/CLIN)

H (mm)	SCANBODY	ADAPTOR	SCREWDRIVER ADAPTOR
10	52.410.105.01-2	50.312.019.01-2	43.621.410.01-2
12	52.412.105.01-2		43.624.410.01-2



### LAB SCANBODY

30.412.001.01-2



## DYNAMIC MILLING TOOL

SHANK	$\alpha_{di}$	DYNAMIC MILLING TOOL	DIGITAL ANALOG
3		33.360.754.01-2	34.612.019.01-2
4	25°	33.460.754.01-2	
6		33.660.754.01-2	



LIBRARY OPTIONS: GH = Gingival Height CH = Cement Height H = Height IG = Adaptor 3mm  $\alpha_s$  = Standard maximum angulation  $\alpha_c$  = Standard maximum angulation  $\alpha_{di}$  = Direct to implant maximum angulation

## SCREWS

DYNAMIC SCREW	LENGTH	SCREWDRIVER
	18	43.618.201.01-2
41.316.071.01-2	24	43.624.201.01-2
	32	43.632.201.01-2



STRAIGHT SCREW	TYPE	SCREWDRIVER
40.316.005.05-2	Hex. 1.27	43.625.105.01-2



## MULTI-UNIT

### STRAIGHT MULTI-UNIT

GH (mm)	ENGAGING
1	42.302.019.01-2



# COMPATIBLE WITH OO20

LIST OF COMPATIBILITIES **AVAILABLE**  
MIS

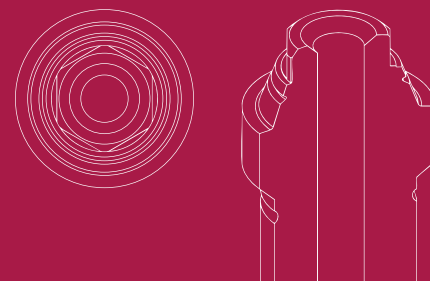

## STANDARD DYNAMIC TIBASE

GH (mm)	$\alpha_s$	$\alpha_c$	NON ENGAGING	ENGAGING
0,6	45°	30°	31.323.020.01-2	-



## DYNAMIC SCANBODY (LAB/CLIN)

H (mm)	SCANBODY	ADAPTOR	SCREWDRIVER ADAPTOR
8	52.408.112.01-2	50.313.020.01-2	43.620.411.01-2



### LAB SCANBODY

30.413.005.01-2



## DYNAMIC MILLING TOOL

SHANK	$\alpha_{di}$	DYNAMIC MILLING TOOL
3		33.390.716.01-2
4	30°	33.490.716.01-2
6		33.690.716.01-2

## ANALOG

DIGITAL ANALOG
34.613.020.01-2



LIBRARY OPTIONS: GH = Gingival Height CH = Cement Height H = Height IG = Adaptor 3mm  $\alpha_s$  = Standard maximum angulation  $\alpha_c$  = Standard maximum angulation  $\alpha_{di}$  = Direct to implant maximum angulation

## SCANBODY REFERENCE

SCANBODY	PEEK PINS	HEIGHT	TYPE	SCREWDRIVER
	49.414.000.01-2	6	A	
	49.415.000.01-2	9	A	
	49.416.000.01-2	13	A	
	49.414.000.02-2	6	B	
	49.415.000.02-2	9	B	
	49.416.000.02-2	13	B	
	49.414.000.03-2	6	C	
	49.415.000.03-2	9	C	
	49.416.000.03-2	13	C	
54.322.020.31-2	49.416.000.04-2	13	D	
	49.416.000.05-2	13	E	
	<b>CAPS</b>	<b>HEIGHT</b>	<b>TYPE</b>	
	49.418.000.01-2	3,8	Regular	
	49.418.000.02-2	3,8	Wide	
	49.419.000.01-2	6	Regular	
	49.419.000.02-2	6	Wide	
	49.420.000.01-2	8	Regular	
	49.420.000.02-2	8	Wide	

43.625.105.01-2



## SCREWS

DYNAMIC SCREW	LENGTH	SCREWDRIVER
	18	43.618.201.01-2
41.316.044.01-2	24	43.624.201.01-2
	32	43.632.201.01-2

STRAIGHT SCREW	TYPE	SCREWDRIVER
40.316.005.06-2	Hex. 1.27	43.625.105.01-2



LIBRARY OPTIONS: GH = Gingival Height CH = Cement Height H = Height IG = Adaptor 3mm Gs = Standard maximum angulation Gc = Standard maximum angulation Gd = Direct to implant maximum angulation

# COMPATIBLE WITH OO21

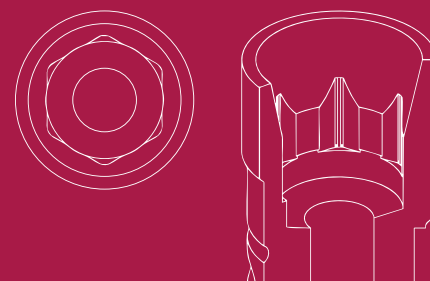

## LIST OF COMPATIBILITIES AVAILABLE

ADIN - ALFA-GATE - BIONER - CONEXÃO SISTEMA DE PRÓTESE - HAHN IMPLANT (GLIDEWELL) - HI-TEC IMPLANT DIRECT - NOBEL BIO CARE - REFLECT - YOUSE IMPLANTS (SWEDEN & MARTINA GROUP)

### STANDARD DYNAMIC TIBASE

GH (mm)	$\alpha_s$	$\alpha_c$	NON ENGAGING	ENGAGING
1,5	43°	24°	31.322.021.01-2	31.312.021.01-2
2	25°	20°	31.322.021.02-2	31.312.021.02-2
3	20°	30°	31.322.021.03-2	31.312.021.03-2
4	15°	30°	31.322.021.04-2	31.312.021.04-2
5	15°	20°	31.322.021.05-2	31.312.021.05-2



### DYNAMIC 3TIBASE

GH (mm)	$\alpha_s$ CH=5mm	$\alpha_s$ CH=7mm	$\alpha_s$ CH=9mm	NON ENGAGING	ENGAGING
1,5	25°	20°	10°	31.322.021.21-2	31.312.021.21-2
3	25°	20°	15°	31.322.021.23-2	31.312.021.23-2



### DYNAMIC SCANBODY (LAB/CLIN)

H (mm)	SCANBODY	ADAPTOR	SCREWDRIVER ADAPTOR
10	52.410.103.01-2		43.621.410.01-2
12	52.412.103.01-2	50.312.021.03-2 (IG=3mm)	43.624.410.01-2



LAB SCANBODY	SCANALOG
30.412.001.01-2	23.412.021.01-2



LIBRARY OPTIONS: GH = Gingival Height CH = Cement Height H = Height IG = Adaptor 3mm  $\alpha_s$  = Standard maximum angulation  $\alpha_c$  = Standard maximum angulation  $\alpha_d$  = Direct to implant maximum angulation

## DYNAMIC MILLING TOOL

## ANALOG

SHANK	$\alpha_{di}$	DYNAMIC MILLING TOOL	ANALOG	DIGITAL ANALOG
3		33.335.754.01-2	22.612.021.01-2	34.612.021.01-2
4	25°	33.435.754.01-2		
6		33.635.754.01-2		



## SCANBODY OP

SCANBODY	PEEK PINS	HEIGHT	TYPE	SCREWDRIVER
54.315.021.21-2	49.414.000.01-2	6	A	43.625.108.01-2
	49.415.000.01-2	9	A	
	49.416.000.01-2	13	A	
	49.414.000.02-2	6	B	
	49.415.000.02-2	9	B	
	49.416.000.02-2	13	B	
	49.414.000.03-2	6	C	
	49.415.000.03-2	9	C	
	49.416.000.03-2	13	C	
	49.416.000.04-2	13	D	
49.416.000.05-2	13	E		



## SCREWS

DYNAMIC SCREW	HIGH	LENGTH	SCREWDRIVER
41.316.073.01-2	41.316.108.01-2	18	43.618.201.01-2
		24	43.624.201.01-2
		32	43.632.201.01-2



STRAIGHT SCREW	TYPE	SCREWDRIVER
40.316.008.02-2	UNIGRIP	43.625.108.01-2



LIBRARY OPTIONS: GH = Gingival Height CH = Cement Height H = Height IG = Adaptor 3mm  $\alpha_s$  = Standard maximum angulation  $\alpha_d$  = Standard maximum angulation  $\alpha_{di}$  = Direct to implant maximum angulation

## MULTI-UNIT

### STRAIGHT MULTI-UNIT

GH (mm)	NON ENGAGING
1	42.302.021.01-2
2	42.302.021.02-2
3	42.302.021.03-2
4	42.302.021.04-2



### ANGULATED MULTI-UNIT 20°

GH (mm)	NON ENGAGING
1,5/2,9	48.312.021.01-2
2,5/3,9	48.312.021.02-2
4,5/5,9	48.312.021.04-2

### ANGULATED MULTI-UNIT 28°

GH (mm)	NON ENGAGING
3,5/5,4	48.612.021.03-2
4,5/6,4	48.612.021.04-2



### INTERNAL MULTI-UNIT

GH (mm)	ENGAGING
2	62.302.021.02-2
3	62.302.021.03-2
4	62.302.021.04-2



# COMPATIBLE WITH OO22

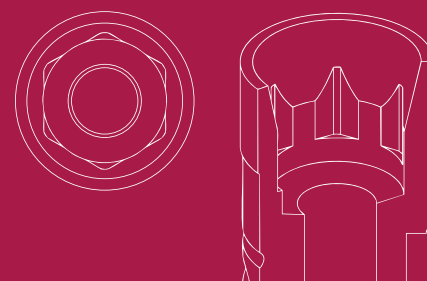

## LIST OF COMPATIBILITIES AVAILABLE

ADIN - ALFA-GATE - HAHN IMPLANT (GLIDEWELL) - HI-TEC - IMPLANT DIRECT - JDENTALCARE - NOBEL BIOCARE  
REFLECT - YOUSE IMPLANTS (SWEDEN & MARTINA GROUP)

### STANDARD DYNAMIC TIBASE

GH (mm)	$\alpha_s$	$\alpha_c$	NON ENGAGING	ENGAGING
1,3	40°	19°	31.323.022.01-2	31.313.022.01-2
2	25°	14°	31.323.022.02-2	31.313.022.02-2
3	20°	30°	31.323.022.03-2	31.313.022.03-2
4	15°	30°	31.323.022.04-2	31.313.022.04-2
5	15°	20°	31.323.022.05-2	31.313.022.05-2



### DYNAMIC 3TIBASE

GH (mm)	$\alpha_s$ CH=5mm	$\alpha_s$ CH=7mm	$\alpha_s$ CH=9mm	NON ENGAGING	ENGAGING
1,3	30°	25°	10°	31.323.022.21-2	31.313.022.21-2
3	20°	20°	10°	31.323.022.23-2	31.313.022.23-2



### DYNAMIC SCANBODY (LAB/CLIN)

H (mm)	SCANBODY	ADAPTOR	SCREWDRIVER ADAPTOR
8	52.408.106.01-2		
10	52.410.101.01-2	50.313.022.01-2 50.313.022.03-2 (IG=3mm)	43.621.410.01-2 43.624.410.01-2
12	52.412.101.01-2		



LAB SCANBODY	SCANALOG
30.413.002.01-2	23.413.022.01-2



LIBRARY OPTIONS: GH = Gingival Height CH = Cement Height H = Height IG = Adaptor 3mm  $\alpha_s$  = Standard maximum angulation  $\alpha_c$  = Standard maximum angulation  $\alpha_d$  = Direct to implant maximum angulation

### DYNAMIC MILLING TOOL

### ANALOG

SHANK	$\alpha_{di}$	DYNAMIC MILLING TOOL	ANALOG	DIGITAL ANALOG
3		33.335.758.01-2	22.613.022.01-2	34.613.022.01-2
4	30°	33.435.758.01-2		
6		33.635.758.01-2		



### SCANBODY OP

SCANBODY	PEEK PINS	HEIGHT	TYPE	SCREWDRIVER
54.315.022.21-2	49.414.000.01-2	6	A	43.625.108.01-2
	49.415.000.01-2	9	A	
	49.416.000.01-2	13	A	
	49.414.000.02-2	6	B	
	49.415.000.02-2	9	B	
	49.416.000.02-2	13	B	
	49.414.000.03-2	6	C	
	49.415.000.03-2	9	C	
	49.416.000.03-2	13	C	
	49.416.000.04-2	13	D	
49.416.000.05-2	13	E		



### SCREWS

DYNAMIC SCREW	HIGH	LENGTH	SCREWDRIVER
41.320.075.01-2	41.320.117.01-2	18	43.618.201.01-2
		24	43.624.201.01-2
		32	43.632.201.01-2



STRAIGHT SCREW	TYPE	SCREWDRIVER
40.320.008.02-2	UNIGRIP	43.625.108.01-2



LIBRARY OPTIONS: GH = Gingival Height CH = Cement Height H = Height IG = Adaptor 3mm  $\alpha_s$  = Standard maximum angulation  $\alpha_i$  = Standard maximum angulation  $\alpha_d$  = Direct to implant maximum angulation

## MULTI-UNIT

### STRAIGHT MULTI-UNIT

GH (mm)	NON ENGAGING
1	42.303.022.01-2
2	42.303.022.02-2
3	42.303.022.03-2
4	42.303.022.04-2



### ANGULATED MULTI-UNIT 20°

GH (mm)	NON ENGAGING
1,5/2,9	48.312.022.01-2
2,5/3,9	48.312.022.02-2

### ANGULATED MULTI-UNIT 28°

GH (mm)	NON ENGAGING
3,5/5,4	48.612.022.03-2
4,5/6,4	48.612.022.04-2



### INTERNAL MULTI-UNIT

GH (mm)	ENGAGING
2	62.303.022.02-2
3	62.303.022.03-2
4	62.303.022.04-2



# COMPATIBLE WITH OO23

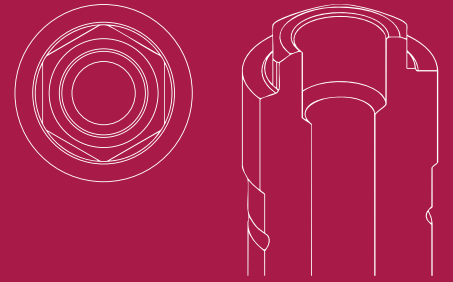

## LIST OF COMPATIBILITIES **AVAILABLE**

AVINENT - BIOGENESIS - BIOHORIZONS - DENTIS - DIO IMPLANT - GT MEDICAL - KLOCKNER - MEGAGEN  
NEOBIO TECH - NOBEL BIOCARE - OSSTEM IMPLANT - RADHEX - STERI-OSS - TBR - TREE-OSS

### STANDARD DYNAMIC TIBASE

GH (mm)	$\alpha_s$	$\alpha_c$	NON ENGAGING	ENGAGING
0,3	45°	30°	31.322.023.01-2	31.312.023.01-2



### DYNAMIC SCANBODY (LAB/CLIN)

H (mm)	SCANBODY	ADAPTOR	SCREWDRIVER ADAPTOR
10	52.410.103.01-2	50.312.023.01-2	43.621.410.01-2
12	52.412.103.01-2		43.624.410.01-2



LAB SCANBODY	SCANALOG
30.412.001.01-2	23.412.023.01-2



### DYNAMIC MILLING TOOL

SHANK	$\alpha_{di}$	DYNAMIC MILLING TOOL	ANALOG	DIGITAL ANALOG
3		33.390.805.01-2	22.612.023.01-2	34.612.023.01-2
4	25°	33.490.805.01-2		
6		33.690.805.01-2		



### ANALOG

LIBRARY OPTIONS: GH = Gingival Height CH = Cement Height H = Height IG = Adaptor 3mm  $\alpha_s$  = Standard maximum angulation  $\alpha_c$  = Standard maximum angulation  $\alpha_{di}$  = Direct to implant maximum angulation

**SCREWS**

DYNAMIC SCREW	LENGTH	SCREWDRIVER
	18	43.618.201.01-2
41.316.059.01-2	24	43.624.201.01-2
	32	43.632.201.01-2



STRAIGHT SCREW	TYPE	SCREWDRIVER
40.316.008.01-2	UNIGRIP	43.625.108.01-2



LIBRARY OPTIONS: GH - Gingival Height CH - Cement Height H - Height IG - Adaptor 3mm G<sub>s</sub> - Standard maximum angulation G<sub>c</sub> - Standard maximum angulation G<sub>d</sub> - Direct to implant maximum angulation

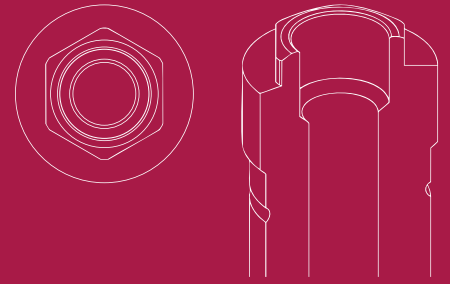

# COMPATIBLE WITH OO24

## LIST OF COMPATIBILITIES AVAILABLE

ACE - ANTHOGR - AVINENT - BIOGENESIS - B&W - BIOGENESIS - BIOMET 3L - BIONER - BTI - BTK - DENTIS - DIO IMPLANTS - EASY IMPLANT - ECKERMANN  
 DSP BIOMEDICAL - EUROTEKNIKA - GALIMPLANT - GMI (ILERIMPLANT) - GT MEDICAL - INTRA-LOCK - KEYSTONE - KLOCKNER - LEADER - MEGAGEN  
 MICRODENT - MIS - MOZO-GRAU (TICARE) - MPI - NEODENT - NOBEL BIOCARE - NORMON - OSSTEM IMPLANT - OSTEOPLUS - OXY - PHIBO - PROCLINIC  
 RADHEX - SIGNO VINCES - SIN IMPLANTS - SOUTHERN IMPLANTS - SYTHEX - TREE-OSS - TRINON - ZIACON

### STANDARD DYNAMIC TIBASE

GH (mm)	$\alpha_s$	$\alpha_c$	NON ENGAGING	ENGAGING
0,3	45°	30°	31.323.024.01-2	31.313.024.01-2
0,5	30°	30°	31.323.024.02-2	31.313.024.02-2



### DYNAMIC 3TIBASE

GH (mm)	$\alpha_s$ CH=5mm	$\alpha_s$ CH=7mm	$\alpha_s$ CH=9mm	NON ENGAGING	ENGAGING
0,3	30°	25°	10°	31.323.024.21-2	31.313.024.21-2
0,5	30°	25°	10°	31.323.024.22-2	31.313.024.22-2
1	30°	25°	10°	31.323.024.23-2	31.313.024.23-2
2	30°	25°	10°	31.323.024.24-2	31.313.024.24-2
3	25°	20°	15°	31.323.024.25-2	31.313.024.25-2
4	25°	20°	15°	31.323.024.26-2	31.313.024.26-2



LAB SCANBODY	SCANALOG
30.413.002.01-2	23.413.024.01-2



### DYNAMIC MILLING TOOL

SHANK	$\alpha_{di}$	DYNAMIC MILLING TOOL
3		33.390.716.01-2
4	30°	33.490.716.01-2
6		33.690.716.01-2

### ANALOG

ANALOG	DIGITAL ANALOG
22.613.024.01-2	34.613.024.01-2



LIBRARY OPTIONS: GH = Gingival Height CH = Cement Height H = Height IG = Adaptor 3mm  $\alpha_s$  = Standard maximum angulation  $\alpha_c$  = Standard maximum angulation  $\alpha_{di}$  = Direct to implant maximum angulation

## SCANBODY OP

SCANBODY	PEEK PINS	HEIGHT	TYPE	SCREWDRIVER
	49.414.000.01-2	6	A	
	49.415.000.01-2	9	A	
	49.416.000.01-2	13	A	
	49.414.000.02-2	6	B	
	49.415.000.02-2	9	B	
54.315.024.21-2	49.416.000.02-2	13	B	43.625.108.01-2
	49.414.000.03-2	6	C	
	49.415.000.03-2	9	C	
	49.416.000.03-2	13	C	
	49.416.000.04-2	13	D	
	49.416.000.05-2	13	E	



## SCREWS

DYNAMIC SCREW	LENGTH	SCREWDRIVER
	18	43.618.201.01-2
41.320.060.01-2	24	43.624.201.01-2
	32	43.632.201.01-2



STRAIGHT SCREW	TYPE	SCREWDRIVER
40.320.008.01-2	UNIGRIP	43.625.108.01-2



## MULTI-UNIT

### STRAIGHT MULTI-UNIT

### MULTI-UNIT 4.0

GH (mm)	NON ENGAGING	GH (mm)	NON ENGAGING
2	42.303.024.02-2	3	61.303.024.03-2
3	42.303.024.03-2		



LIBRARY OPTIONS: GH = Gingival Height CH = Cement Height H = Height IG = Adaptor 3mm G = Standard maximum angulation G = Standard maximum angulation G = Direct to implant maximum angulation



# COMPATIBLE WITH OO25

## LIST OF COMPATIBILITIES **AVAILABLE**

AB - ACE - ADIN - AVINENT - BIOHORIZONS - BIOMET 3L - BIONER - CORTEX - EASY IMPLANT - EOROTEKNIKA  
 GALIMPLANT - GMI (ILERPLANT) - HAHN IMPLANT (GLIDEWELL) - IMPLANTSWISS - JDENTALCARE - MEDINTAKA  
 MEGAGEN - NEOBITOTECH - NEODENT - OSSTEM IMPLANT - SEWON MEDIX - SIN IMPLANTS - TREE-OSS - WIN

### STANDARD DYNAMIC TIBASE

GH (mm)	$\alpha_s$	$\alpha_c$	NON ENGAGING	ENGAGING
0,3	45°	30°	31.323.025.01-2	-



### DYNAMIC 3TIBASE

GH (mm)	$\alpha_s$ CH=5mm	$\alpha_s$ CH=7mm	$\alpha_s$ CH=9mm	NON ENGAGING	ENGAGING
0,3	30°	25°	10°	31.323.025.21-2	-



### DYNAMIC SCANBODY (LAB/CLIN)

H (mm)	SCANBODY	ADAPTOR	SCREWDRIVER ADAPTOR
8	52.408.112.01-2	50.313.025.02-2	43.620.411.01-2
10	52.410.111.01-2	50.313.025.01-2	43.621.410.01-2 43.624.410.01-2



LAB SCANBODY	MINI SCANBODY	SCANALOG
30.413.005.01-2	53.413.025.01-2	23.413.025.01-2 23.313.025.01-2 (Titanium)



LIBRARY OPTIONS: GH = Gingival Height CH = Cement Height H = Height IG = Adaptor 3mm  $\alpha_s$  = Standard maximum angulation  $\alpha_c$  = Standard maximum angulation  $\alpha_d$  = Direct to implant maximum angulation

**DYNAMIC MILLING TOOL**

**ANALOG**

SHANK	$\alpha_{di}$	DYNAMIC MILLING TOOL	ANALOG	DIGITAL ANALOG
3		33.390.716.01-2	22.613.025.01-2	34.613.025.01-2
4	30°	33.490.716.01-2		
6		33.690.716.01-2		



**SCANBODY REFERENCE**

SCANBODY	PEEK PINS	HEIGHT	TYPE	SCREWDRIVER
	49.414.000.01-2	6	A	
	49.415.000.01-2	9	A	
	49.416.000.01-2	13	A	
	49.414.000.02-2	6	B	
	49.415.000.02-2	9	B	
	49.416.000.02-2	13	B	
	49.414.000.03-2	6	C	
	49.415.000.03-2	9	C	
	49.416.000.03-2	13	C	
54.322.025.31-2	49.416.000.04-2	13	D	43.625.108.01-2
	49.416.000.05-2	13	E	
	<b>CAPS</b>	<b>HEIGHT</b>	<b>TYPE</b>	
	49.418.000.01-2	3,8	Regular	
	49.418.000.02-2	3,8	Wide	
	49.419.000.01-2	6	Regular	
	49.419.000.02-2	6	Wide	
	49.420.000.01-2	8	Regular	
	49.420.000.02-2	8	Wide	



LIBRARY OPTIONS: GH = Gingival Height CH = Cement Height H = Height IG = Adaptor 3mm  $\alpha_s$  = Standard maximum angulation  $\alpha_d$  = Standard maximum angulation  $\alpha_i$  = Direct to implant maximum angulation

**SCREWS**

DYNAMIC SCREW	DYNAMIC SCREW Ø2,6	LENGTH	SCREWDRIVER
		18	43.618.201.01-2
41.314.039.01-2	41.314.050.31-2 (Temporary or Zirconio Direct MU)	24	43.624.201.01-2
		32	43.632.201.01-2



STRAIGHT SCREW	TYPE	SCREWDRIVER
40.314.008.01-2	UNIGRIP	43.625.108.01-2



# COMPATIBLE WITH OO26

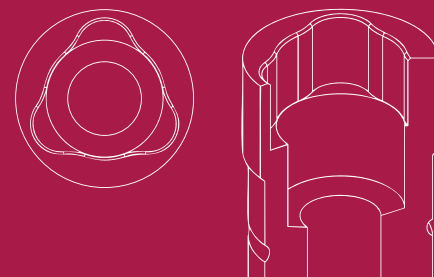

## LIST OF COMPATIBILITIES AVAILABLE

ACE - IMPLANT DIRECT - NOBEL BIOCARE - SOUTHERN IMPLANTS - TREE-OSS

### STANDARD DYNAMIC TIBASE

GH (mm)	$\alpha_s$	$\alpha_c$	NON ENGAGING	ENGAGING
0,5	45°	29°	31.322.026.01-2	31.312.026.01-2
1,2	25°	22°	31.322.026.02-2	31.312.026.02-2



### DYNAMIC 3TIBASE

GH (mm)	$\alpha_s$ CH=5mm	$\alpha_s$ CH=7mm	$\alpha_s$ CH=9mm	NON ENGAGING	ENGAGING
0,5	25°	20°	10°	31.322.026.21-2	31.312.026.21-2



### DYNAMIC SCANBODY (LAB/CLIN)

H (mm)	SCANBODY	ADAPTOR	SCREWDRIVER ADAPTOR
10	52.410.108.01-2	50.312.026.04-2 (IG=3mm)	43.621.410.01-2
12	52.412.108.01-2		43.624.410.01-2



LAB SCANBODY
30.412.001.01-2



LIBRARY OPTIONS: GH = Gingival Height CH = Cement Height H = Height IG = Adaptor 3mm  $\alpha_s$  = Standard maximum angulation  $\alpha_c$  = Standard maximum angulation  $\alpha_d$  = Direct to implant maximum angulation

**DYNAMIC MILLING TOOL**

**ANALOG**

SHANK	$\alpha_{di}$	DYNAMIC MILLING TOOL	ANALOG	DIGITAL ANALOG
3		33.390.805.01-2	22.612.026.01-2	34.612.026.01-2
4	25°	33.490.805.01-2		
6		33.690.805.01-2		



**SCANBODY OP**

SCANBODY	PEEK PINS	HEIGHT	TYPE	SCREWDRIVER
	49.414.000.01-2	6	A	
	49.415.000.01-2	9	A	
	49.416.000.01-2	13	A	
	49.414.000.02-2	6	B	
	49.415.000.02-2	9	B	
54.315.026.21-2	49.416.000.02-2	13	B	43.625.108.01-2
	49.414.000.03-2	6	C	
	49.415.000.03-2	9	C	
	49.416.000.03-2	13	C	
	49.416.000.04-2	13	D	
	49.416.000.05-2	13	E	



**SCREWS**

DYNAMIC SCREW	LENGTH	SCREWDRIVER
	18	43.618.201.01-2
41.318.075.01-2	24	43.624.201.01-2
	32	43.632.201.01-2



STRAIGHT SCREW	TYPE	SCREWDRIVER
40.318.008.01-2	UNIGRIP	43.625.108.01-2



LIBRARY OPTIONS: GH = Gingival Height CH = Cement Height H = Height IG = Adaptor 3mm  $\alpha_s$  = Standard maximum angulation  $\alpha_d$  = Standard maximum angulation  $\alpha_{di}$  = Direct to implant maximum angulation

# COMPATIBLE WITH OO27

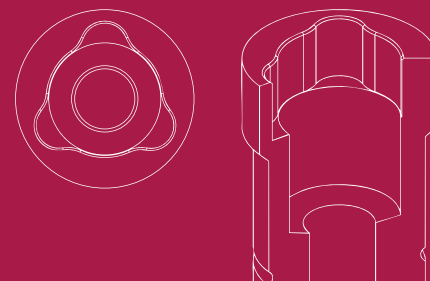

## LIST OF COMPATIBILITIES AVAILABLE

ADIN - IMPLANT DIRECT - NOBEL BIOCARE - SOUTHERN IMPLANTS - TREE-OSS

### STANDARD DYNAMIC TIBASE

GH (mm)	$\alpha_S$	$\alpha_C$	NON ENGAGING	ENGAGING
0,3	35°	29°	31.323.027.01-2	31.313.027.01-2
1,2	25°	22°	31.323.027.02-2	31.313.027.02-2



### DYNAMIC 3TIBASE

GH (mm)	$\alpha_S$ CH=5mm	$\alpha_S$ CH=7mm	$\alpha_S$ CH=9mm	NON ENGAGING	ENGAGING
0,3	25°	20°	10°	31.323.027.21-2	31.313.027.21-2



### DYNAMIC SCANBODY (LAB/CLIN)

H (mm)	SCANBODY	ADAPTOR	SCREWDRIVER ADAPTOR
10	52.410.109.01-2	50.313.027.01-2	43.621.410.01-2
12	52.412.109.01-2		43.624.410.01-2



#### LAB SCANBODY

30.413.002.01-2



LIBRARY OPTIONS: GH = Gingival Height CH = Cement Height H = Height IG = Adaptor 3mm  $\alpha_S$  = Standard maximum angulation  $\alpha_C$  = Standard maximum angulation  $\alpha_D$  = Direct to implant maximum angulation

## DYNAMIC MILLING TOOL

## ANALOG

SHANK	$\alpha_{di}$	DYNAMIC MILLING TOOL	ANALOG	DIGITAL ANALOG
3		33.390.958.01-2	22.613.027.01-2	34.613.027.01-2
4	30°	33.490.958.01-2		
6		33.690.958.01-2		



## SCANBODY OP

SCANBODY	PEEK PINS	HEIGHT	TYPE	SCREWDRIVER
	49.414.000.01-2	6	A	
	49.415.000.01-2	9	A	
	49.416.000.01-2	13	A	
	49.414.000.02-2	6	B	
	49.415.000.02-2	9	B	
54.315.027.21-2	49.416.000.02-2	13	B	43.625.108.01-2
	49.414.000.03-2	6	C	
	49.415.000.03-2	9	C	
	49.416.000.03-2	13	C	
	49.416.000.04-2	13	D	
	49.416.000.05-2	13	E	



## SCREWS

DYNAMIC SCREW	LENGTH	SCREWDRIVER
	18	43.618.201.01-2
41.320.090.01-2	24	43.624.201.01-2
	32	43.632.201.01-2

STRAIGHT SCREW	TYPE	SCREWDRIVER
40.320.008.03-2	UNIGRIP	43.625.108.01-2



LIBRARY OPTIONS: GH = Gingival Height CH = Cement Height H = Height IG = Adaptor 3mm  $\alpha_s$  = Standard maximum angulation  $\alpha_d$  = Standard maximum angulation  $\alpha_i$  = Direct to implant maximum angulation

# COMPATIBLE WITH OO28

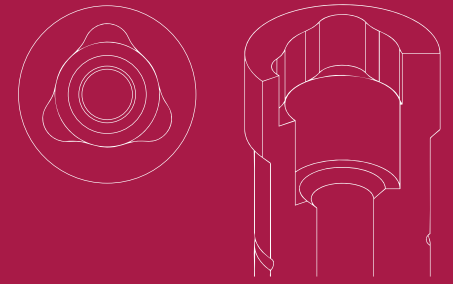

## LIST OF COMPATIBILITIES **AVAILABLE**

ACE - IMPLANT DIRECT - NOBEL BIO CARE - SOUTHERN IMPLANTS - TREE-OSS

### STANDARD DYNAMIC TIBASE

GH (mm)	$\alpha_s$	$\alpha_c$	NON ENGAGING	ENGAGING
0,3	35°	30°	31.324.028.01-2	31.314.028.01-2



### DYNAMIC SCANBODY (LAB/CLIN)

H (mm)	SCANBODY	ADAPTOR	SCREWDRIVER ADAPTOR
10	52.410.109.01-2	50.314.028.01-2	43.621.410.01-2
12	52.412.109.01-2		43.624.410.01-2



#### LAB SCANBODY

30.413.002.01-2



### DYNAMIC MILLING TOOL

SHANK	$\alpha_{di}$	DYNAMIC MILLING TOOL	ANALOG	DIGITAL ANALOG
3		33.390.958.01-2	22.614.028.01-2	34.614.028.01-2
4	30°	33.490.958.01-2		
6		33.690.958.01-2		



LIBRARY OPTIONS: GH = Gingival Height CH = Cement Height H = Height IG = Adaptor 3mm  $\alpha_s$  = Standard maximum angulation  $\alpha_c$  = Standard maximum angulation  $\alpha_{di}$  = Direct to implant maximum angulation

## SCANBODY OP

SCANBODY	PEEK PINS	HEIGHT	TYPE	SCREWDRIVER
54.315.028.21-2	49.414.000.01-2	6	A	43.625.108.01-2
	49.415.000.01-2	9	A	
	49.416.000.01-2	13	A	
	49.414.000.02-2	6	B	
	49.415.000.02-2	9	B	
	49.416.000.02-2	13	B	
	49.414.000.03-2	6	C	
	49.415.000.03-2	9	C	
	49.416.000.03-2	13	C	
	49.416.000.04-2	13	D	
49.416.000.05-2	13	E		



## SCREWS

DYNAMIC SCREW	LENGTH	SCREWDRIVER
41.320.090.01-2	18	43.618.201.01-2
	24	43.624.201.01-2
	32	43.632.201.01-2



STRAIGHT SCREW	TYPE	SCREWDRIVER
40.320.008.03-2	UNIGRIP	43.625.108.01-2



LIBRARY OPTIONS: GH = Gingival Height CH = Cement Height H = Height IG = Adaptor 3mm αs = Standard maximum angulation αc = Standard maximum angulation αd = Direct to implant maximum angulation

# COMPATIBLE WITH OO29

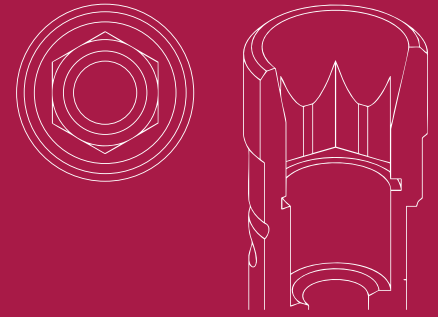

## LIST OF COMPATIBILITIES AVAILABLE

BIOCONCEPT - BTK - NEOBIOTECH - OSSTEM IMPLANT - PALTOP - SEWON MEDIX

### STANDARD DYNAMIC TIBASE

GH (mm)	$\alpha_s$	$\alpha_c$	NON ENGAGING	ENGAGING
1,2	30°	23°	31.322.029.01-2	31.312.029.01-2
2	25°	15°	31.322.029.02-2	31.312.029.02-2
3	20°	25°	31.322.029.03-2	31.312.029.03-2
4	15°	25°	31.322.029.04-2	31.312.029.04-2



### DYNAMIC 3TIBASE

GH (mm)	$\alpha_s$ CH=5mm	$\alpha_s$ CH=7mm	$\alpha_s$ CH=9mm	NON ENGAGING	ENGAGING
1,2	25°	20°	20°	31.322.029.21-2	31.312.029.21-2
2	25°	20°	15°	-	31.312.029.22-2



### DYNAMIC SCANBODY (LAB/CLIN)

H (mm)	SCANBODY	ADAPTOR	SCREWDRIVER ADAPTOR
10	52.410.103.01-2	50.312.029.01-2	43.621.410.01-2
12	52.412.103.01-2	50.312.029.03-2 (IG=3mm)	43.624.410.01-2



LAB SCANBODY	SCANALOG
30.412.001.01-2	23.412.029.01-2



LIBRARY OPTIONS: GH = Gingival Height CH = Cement Height H = Height IG = Adaptor 3mm  $\alpha_s$  = Standard maximum angulation  $\alpha_c$  = Standard maximum angulation  $\alpha_d$  = Direct to implant maximum angulation

### DYNAMIC MILLING TOOL

### ANALOG

SHANK	$\alpha_{di}$	DYNAMIC MILLING TOOL	DIGITAL ANALOG
3		33.345.804.01-2	34.613.029.01-2
4	20°	33.445.804.01-2	
6		33.645.804.01-2	



### SCANBODY OP

SCANBODY	PEEK PINS	HEIGHT	TYPE	SCREWDRIVER
54.315.029.21-2	49.414.000.01-2	6	A	43.601.103.02-2
	49.415.000.01-2	9	A	
	49.416.000.01-2	13	A	
	49.414.000.02-2	6	B	
	49.415.000.02-2	9	B	
	49.416.000.02-2	13	B	
	49.414.000.03-2	6	C	
	49.415.000.03-2	9	C	
	49.416.000.03-2	13	C	
	49.416.000.04-2	13	D	
49.416.000.05-2	13	E		



### SCREWS

DYNAMIC SCREW	HIGH	LENGTH	SCREWDRIVER
41.316.094.01-2	41.316.132.01-2	18	43.618.201.01-2
		24	43.624.201.01-2
		32	43.632.201.01-2



STRAIGHT SCREW	TYPE	SCREWDRIVER
40.316.003.02-2	Hex. 1.20	43.601.103.02-2



LIBRARY OPTIONS: GH = Gingival Height CH = Cement Height H = Height IG = Adaptor 3mm Gs = Standard maximum angulation Gd = Standard maximum angulation Gd = Direct to implant maximum angulation

## MULTI-UNIT

### STRAIGHT MULTI-UNIT

GH (mm)	NON ENGAGING
1	42.302.029.01-2
2	42.302.029.02-2
3	42.302.029.03-2
4	42.302.029.04-2



### ANGULATED MULTI-UNIT 20°

GH (mm)	NON ENGAGING
2,5/3,9	48.312.029.02-2
3,5/4,9	48.312.029.03-2
4,5/5,9	48.312.029.04-2



### INTERNAL MULTI-UNIT

GH (mm)	ENGAGING
2	62.302.029.02-2
4	62.302.029.04-2



# COMPATIBLE WITH OO30

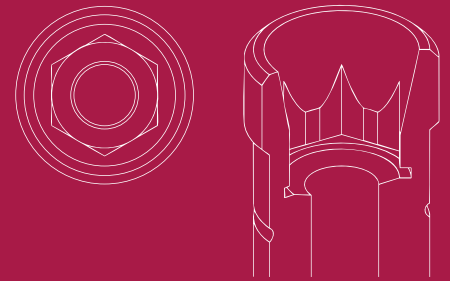

## LIST OF COMPATIBILITIES AVAILABLE

BIOCONCEPT - BIOTEM - COLLELMEDI - DENTEM - DENTIS - DENTIUM - DIO IMPLANTS - EASY IMPLANT  
F&B IMPLANT (FIT & BRILLIANT) - IBS - IDO IMPLANTS - IMPLANTSWISS - MEGADENT - NEOBIOTECH - OSSTEM IMPLANT  
POINT IMPLANT - SEWON MEDIX - YES IMPLANT

### STANDARD DYNAMIC TIBASE

GH (mm)	$\alpha_S$	$\alpha_C$	NON ENGAGING	ENGAGING
1,1	42°	25°	31.323.030.01-2	31.313.030.01-2
2	25°	15°	31.323.030.02-2	31.313.030.02-2
3	20°	30°	31.323.030.03-2	31.313.030.03-2
4	15°	30°	31.323.030.04-2	31.313.030.04-2



### DYNAMIC 3TIBASE

GH (mm)	$\alpha_S$ CH=5mm	$\alpha_S$ CH=7mm	$\alpha_S$ CH=9mm	NON ENGAGING	ENGAGING
1,1	25°	20°	10°	31.323.030.21-2	31.313.030.21-2
2	25°	20°	15°	31.323.030.22-2	31.313.030.22-2
3	25°	20°	10°	31.323.030.23-2	31.313.030.23-2



### DYNAMIC SCANBODY (LAB/CLIN)

H (mm)	SCANBODY	ADAPTOR	SCREWDRIVER ADAPTOR
8	52.408.101.01-2		
10	52.410.101.01-2	50.313.030.01-2 50.313.030.03-2 (IG=3mm)	43.621.410.01-2 43.624.410.01-2
12	52.412.101.01-2		



LAB SCANBODY	SCANALOG
30.413.002.01-2	23.413.030.01-2



LIBRARY OPTIONS: GH = Gingival Height CH = Cement Height H = Height IG = Adaptor 3mm  $\alpha_S$  = Standard maximum angulation  $\alpha_C$  = Standard maximum angulation  $\alpha_D$  = Direct to implant maximum angulation

## DYNAMIC MILLING TOOL

## ANALOG

SHANK	$\alpha_{di}$	DYNAMIC MILLING TOOL	DIGITAL ANALOG
3		33.345.808.01-2	34.613.030.01-2
4	30°	33.445.808.01-2	
6		33.645.808.01-2	



## SCANBODY OP

SCANBODY	PEEK PINS	HEIGHT	TYPE	SCREWDRIVER
54.315.030.21-2	49.414.000.01-2	6	A	43.601.103.02-2
	49.415.000.01-2	9	A	
	49.416.000.01-2	13	A	
	49.414.000.02-2	6	B	
	49.415.000.02-2	9	B	
	49.416.000.02-2	13	B	
	49.414.000.03-2	6	C	
	49.415.000.03-2	9	C	
	49.416.000.03-2	13	C	
	49.416.000.04-2	13	D	
49.416.000.05-2	13	E		



## SCREWS

DYNAMIC SCREW	HIGH	LENGTH	SCREWDRIVER
41.320.079.01-2	41.320.125.01-2	18	43.618.201.01-2
		24	43.624.201.01-2
		32	43.632.201.01-2



STRAIGHT SCREW	TYPE	SCREWDRIVER
40.320.003.04-2	Hex. 1.20	43.601.103.02-2



LIBRARY OPTIONS: **OK** = Original height **OK** = Correct height **H** = Height **AD** = Adaptor (mm) **SL** = Standard maximum angulation **SL** = Standard maximum angulation **SL** = Decal to replace maximum angulation

## MULTI-UNIT

### STRAIGHT MULTI-UNIT

GH (mm)	NON ENGAGING
1	42.303.030.01-2
2	42.303.030.02-2
3	42.303.030.03-2
4	42.303.030.04-2
5	42.303.030.05-2



### ANGULATED MULTI-UNIT 20°

GH (mm)	ENGAGING
1,5/2,9	48.312.030.01-2
2,5/3,9	48.312.030.02-2
3,5/4,9	48.312.030.03-2
4,5/5,9	48.312.030.04-2



### INTERNAL MULTI-UNIT

GH (mm)	ENGAGING
2	62.303.030.02-2
3	62.303.030.03-2
4	62.303.030.04-2



# COMPATIBLE WITH OO33

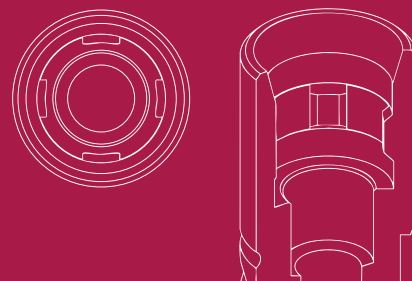

LIST OF COMPATIBILITIES **AVAILABLE**  
BIOCONCEPT - IHDE DENTAL (IMBIODENT) - STRAUMANN

## STANDARD DYNAMIC TIBASE

GH (mm)	$\alpha_s$	$\alpha_c$	NON ENGAGING	ENGAGING
1,3	38°	18°	31.322.033.01-2	31.312.033.01-2
2	20°	14°	31.322.033.02-2	31.312.033.02-2
3	15°	25°	31.322.033.03-2	31.312.033.03-2
4	15°	25°	31.322.033.04-2	31.312.033.04-2



## DYNAMIC 3TIBASE

GH (mm)	$\alpha_s$ CH=5mm	$\alpha_s$ CH=7mm	$\alpha_s$ CH=9mm	NON ENGAGING	ENGAGING
1,3	25°	20°	20°	31.322.033.21-2	31.312.033.21-2
3	25°	20°	15°	31.322.033.23-2	31.312.033.23-2



## DYNAMIC SCANBODY (LAB/CLIN)

H (mm)	SCANBODY	ADAPTOR	SCREWDRIVER ADAPTOR
8	52.408.106.01-2		
10	52.410.106.01-2	50.312.033.03-2 (IG=3mm)	43.621.410.01-2 43.624.410.01-2
12	52.412.106.01-2		



LAB SCANBODY	SCANALOG
30.412.001.01-2	23.412.033.01-2



LIBRARY OPTIONS: GH = Gingival Height CH = Cement Height H = Height IG = Adaptor 3mm  $\alpha_s$  = Standard maximum angulation  $\alpha_c$  = Standard maximum angulation  $\alpha_d$  = Direct to implant maximum angulation

### DYNAMIC MILLING TOOL

### ANALOG

SHANK	$\alpha_{di}$	DYNAMIC MILLING TOOL	ANALOG	DIGITAL ANALOG
3		33.315.804.01-2	22.612.033.01-2	34.612.033.01-2
4	25°	33.415.804.01-2		
6		33.615.804.01-2		



### SCANBODY OP

SCANBODY	PEEK PINS	HEIGHT	TYPE	SCREWDRIVER
54.315.033.21-2	49.414.000.01-2	6	A	43.601.107.01-2
	49.415.000.01-2	9	A	
	49.416.000.01-2	13	A	
	49.414.000.02-2	6	B	
	49.415.000.02-2	9	B	
	49.416.000.02-2	13	B	
	49.414.000.03-2	6	C	
	49.415.000.03-2	9	C	
	49.416.000.03-2	13	C	
	49.416.000.04-2	13	D	
49.416.000.05-2	13	E		



### SCREWS

DYNAMIC SCREW	HIGH	LENGTH	SCREWDRIVER
41.316.078.01-2	41.316.124.01-2	18	43.618.201.01-2
		24	43.624.201.01-2
		32	43.632.201.01-2



STRAIGHT SCREW	TYPE	SCREWDRIVER
40.316.007.01-2	TORX T6	43.601.107.01-2



LIBRARY OPTIONS: GH = Gingival Height CH = Cement Height H = Height IG = Adaptor 3mm  $\alpha_s$  = Standard maximum angulation  $\alpha_d$  = Standard maximum angulation  $\alpha_{di}$  = Direct to implant maximum angulation

## MULTI-UNIT

### STRAIGHT MULTI-UNIT

GH (mm)	NON ENGAGING
1	42.302.033.01-2
2	42.302.033.02-2
3	42.302.033.03-2
4	42.302.033.04-2



### ANGULATED MULTI-UNIT 20°

GH (mm)	ENGAGING
2,5/3,9	48.312.033.02-2
3,5/4,9	48.312.033.03-2
4,5/5,9	48.312.033.04-2



### INTERNAL MULTI-UNIT

GH (mm)	ENGAGING
4	62.302.033.04-2



# COMPATIBLE WITH OO35

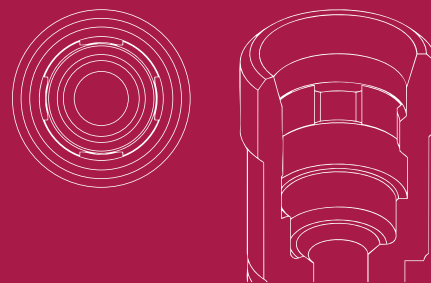

## LIST OF COMPATIBILITIES AVAILABLE

BIOCONCEPT - IHDE DENTAL (IMBIODENT) - STRAUMANN

### STANDARD DYNAMIC TIBASE

GH (mm)	$\alpha_s$	$\alpha_c$	NON ENGAGING	ENGAGING
1,1	39°	18°	31.323.035.01-2	31.313.035.01-2
2	20°	14°	31.323.035.02-2	31.313.035.02-2
3	15°	30°	31.323.035.03-2	31.313.035.03-2
4	15°	30°	31.323.035.04-2	31.313.035.04-2



### DYNAMIC 3TIBASE

GH (mm)	$\alpha_s$ CH=5mm	$\alpha_s$ CH=5mm	$\alpha_s$ CH=5mm	NON ENGAGING	ENGAGING
1,1	25°	20°	10°	31.323.035.21-2	31.313.035.21-2
3	20°	15°	10°	31.323.035.23-2	31.313.035.23-2



### DYNAMIC SCANBODY (LAB/CLIN)

H (mm)	SCANBODY	ADAPTOR	SCREWDRIVER ADAPTOR
10	52.410.107.01-2	50.313.035.01-2	43.621.410.01-2
12	52.412.107.01-2	50.313.035.03-2 (IG=3mm)	43.624.410.01-2



LAB SCANBODY	SCANALOG
30.413.002.01-2	23.413.035.01-2



LIBRARY OPTIONS: GH = Gingival Height CH = Cement Height H = Height IG = Adaptor 3mm  $\alpha_s$  = Standard maximum angulation  $\alpha_c$  = Standard maximum angulation  $\alpha_d$  = Direct to implant maximum angulation

### DYNAMIC MILLING TOOL

### ANALOG

SHANK	$\alpha_{di}$	DYNAMIC MILLING TOOL	ANALOG	DIGITAL ANALOG
3		33.315.804.01-2	22.613.035.01-2	34.613.035.01-2
4	25°	33.415.804.01-2		
6		33.615.804.01-2		



### SCANBODY OP

SCANBODY	PEEK PINS	HEIGHT	TYPE	SCREWDRIVER
54.315.035.21-2	49.414.000.01-2	6	A	43.601.107.01-2
	49.415.000.01-2	9	A	
	49.416.000.01-2	13	A	
	49.414.000.02-2	6	B	
	49.415.000.02-2	9	B	
	49.416.000.02-2	13	B	
	49.414.000.03-2	6	C	
	49.415.000.03-2	9	C	
	49.416.000.03-2	13	C	
	49.416.000.04-2	13	D	
49.416.000.05-2	13	E		



### SCREWS

DYNAMIC SCREW	HIGH	LENGTH	SCREWDRIVER
41.316.078.01-2	41.316.124.01-2	18	43.618.201.01-2
		24	43.624.201.01-2
		32	43.632.201.01-2



STRAIGHT SCREW	TYPE	SCREWDRIVER
40.316.007.01-2	TORX T6	43.601.107.01-2



LIBRARY OPTIONS: GH = Gingival Height CH = Cement Height H = Height IG = Adaptor 3mm  $\alpha_s$  = Standard maximum angulation  $\alpha_d$  = Standard maximum angulation  $\alpha_i$  = Direct to implant maximum angulation

## MULTI-UNIT

### STRAIGHT MULTI-UNIT

GH (mm)	NON ENGAGING
1	42.303.035.01-2
2	42.303.035.02-2
3	42.303.035.03-2
4	42.303.035.04-2



### ANGULATED MULTI-UNIT 20°

GH (mm)	ENGAGING
2,5/3,9	48.312.035.02-2
3,5/4,9	48.312.035.03-2



# COMPATIBLE WITH OO37

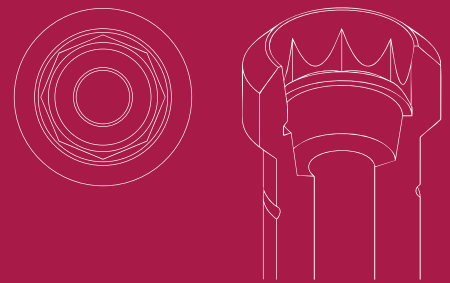

## LIST OF COMPATIBILITIES AVAILABLE

ACE - ANTHOGRYR - BIOCONCEPT - BIOGENESIS - DENTIUM - EUTOTEKNIKA - GT MEDICAL - IMPLANT DIRECT  
MEGAGEN - PROCLINIC - SOUTHERN IMPLANTS - STRAUMANN - TRINON - ZIACOM

### STANDARD DYNAMIC TIBASE

GH (mm)	$\alpha_S$	$\alpha_C$	NON ENGAGING	ENGAGING
0,6	45°	25°	31.323.037.01-2	31.313.037.01-2



### DYNAMIC 3TIBASE

GH (mm)	$\alpha_S$ CH=5mm	$\alpha_S$ CH=7mm	$\alpha_S$ CH=9mm	NON ENGAGING	ENGAGING
0,6	30°	25°	15°	31.323.037.21-2	31.313.037.21-2



### DYNAMIC SCANBODY (LAB/CLIN)

H (mm)	SCANBODY	ADAPTOR	SCREWDRIVER ADAPTOR
8	52.408.110.01-2		
10	52.410.110.01-2	50.313.037.04-2 (IG=3mm)	43.621.410.01-2 43.624.410.01-2
12	52.412.110.01-2		



LAB SCANBODY	SCANALOG
30.413.004.01-2	23.413.037.01-2



LIBRARY OPTIONS: GH = Gingival Height CH = Cement Height H = Height IG = Adaptor 3mm  $\alpha_S$  = Standard maximum angulation  $\alpha_C$  = Standard maximum angulation  $\alpha_D$  = Direct to implant maximum angulation

## DYNAMIC MILLING TOOL

## ANALOG

SHANK	$\alpha_{di}$	DYNAMIC MILLING TOOL	ANALOG	DIGITAL ANALOG
3		33.315.708.01-2	22.613.037.01-2	34.613.037.01-2
4	30°	33.415.708.01-2		
6		33.615.708.01-2		



## SCANBODY OP

SCANBODY	PEEK PINS	HEIGHT	TYPE	SCREWDRIVER
54.315.037.21-2	49.414.000.01-2	6	A	43.601.107.01-2
	49.415.000.01-2	9	A	
	49.416.000.01-2	13	A	
	49.414.000.02-2	6	B	
	49.415.000.02-2	9	B	
	49.416.000.02-2	13	B	
	49.414.000.03-2	6	C	
	49.415.000.03-2	9	C	
	49.416.000.03-2	13	C	
	49.416.000.04-2	13	D	
	49.416.000.05-2	13	E	



## SCREWS

DYNAMIC SCREW	LENGTH	SCREWDRIVER
41.320.067.01-2	18	43.618.201.01-2
	24	43.624.201.01-2
	32	43.632.201.01-2



STRAIGHT SCREW	TYPE	SCREWDRIVER
40.320.007.01-2	TORX T6	43.601.107.01-2



LIBRARY OPTIONS: GH = Gingival Height CH = Cement Height H = Height IG = Adaptor 3mm  $\alpha_s$  = Standard maximum angulation  $\alpha_d$  = Standard maximum angulation  $\alpha_i$  = Direct to implant maximum angulation

## MULTI-UNIT

### STRAIGHT MULTI-UNIT

GH (mm)	NON ENGAGING
1	42.303.037.01-2



# COMPATIBLE WITH OO38

## LIST OF COMPATIBILITIES AVAILABLE

XIVE

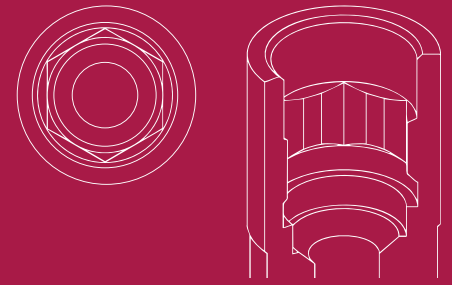

### STANDARD DYNAMIC TIBASE

GH (mm)	$\alpha_s$	$\alpha_c$	NON ENGAGING	ENGAGING
0,7	45°	29°	31.322.038.01-2	31.312.038.01-2



### DYNAMIC 3TIBASE

GH (mm)	$\alpha_s$ CH=5mm	$\alpha_s$ CH=7mm	$\alpha_s$ CH=9mm	NON ENGAGING	ENGAGING
0,7	30°	25°	10°	31.322.038.21-2	31.312.038.21-2



### DYNAMIC SCANBODY (LAB/CLIN)

H (mm)	SCANBODY	ADAPTOR	SCREWDRIVER ADAPTOR
10	52.410.103.01-2	50.312.038.01-2	43.621.410.01-2
12	52.412.103.01-2		43.624.410.01-2



#### LAB SCANBODY

30.412.001.01-2



### DYNAMIC MILLING TOOL

SHANK	$\alpha_{di}$	DYNAMIC MILLING TOOL	DIGITAL ANALOG
3		33.345.804.01-2	34.612.038.01-2
4	25°	33.445.804.01-2	
6		33.645.804.01-2	



LIBRARY OPTIONS: GH = Gingival Height CH = Cement Height H = Height IG = Adaptor 3mm  $\alpha_s$  = Standard maximum angulation  $\alpha_c$  = Standard maximum angulation  $\alpha_{di}$  = Direct to implant maximum angulation

**SCREWS**

DYNAMIC SCREW	LENGTH	SCREWDRIVER
	18	43.618.201.01-2
41.316.081.01-2	24	43.624.201.01-2
	32	43.632.201.01-2



STRAIGHT SCREW	TYPE	SCREWDRIVER
40.316.004.02-2	Hex. 1.25	43.601.104.01-2



# COMPATIBLE WITH 0039

## LIST OF COMPATIBILITIES AVAILABLE

SIN IMPLANTS - XIVE

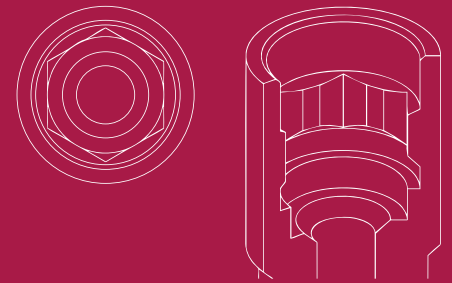

### STANDARD DYNAMIC TIBASE

GH (mm)	$\alpha_s$	$\alpha_c$	NON ENGAGING	ENGAGING
0,7	45°	29°	31.323.039.01-2	31.313.039.01-2
2	25°	-	31.323.039.03-2	31.313.039.03-2



### DYNAMIC 3TIBASE

GH (mm)	$\alpha_s$ CH-5mm	$\alpha_s$ CH-7mm	$\alpha_s$ CH-9mm	NON ENGAGING	ENGAGING
0,7	30°	25°	10°	31.323.039.21-2	31.313.039.21-2



### DYNAMIC SCANBODY (LAB/CLIN)

H (mm)	SCANBODY	ADAPTOR	SCREWDRIVER ADAPTOR
10	52.410.114.01-2	50.313.039.01-2	43.621.410.01-2
12	52.412.114.01-2		43.624.410.01-2



#### LAB SCANBODY

30.413.002.01-2



LIBRARY OPTIONS: GH = Gingival Height CH = Cement Height H = Height IG = Adaptor 3mm  $\alpha_s$  = Standard maximum angulation  $\alpha_c$  = Standard maximum angulation  $\alpha_d$  = Direct to implant maximum angulation

## DYNAMIC MILLING TOOL

## ANALOG

SHANK	$\alpha_{di}$	DYNAMIC MILLING TOOL	DIGITAL ANALOG
3		33.345.856.01-2	34.613.039.01-2
4	25°	33.445.856.01-2	
6		33.645.856.01-2	



## SCREWS

DYNAMIC SCREW	LENGTH	SCREWDRIVER
	18	43.618.201.01-2
41.316.081.01-2	24	43.624.201.01-2
	32	43.632.201.01-2



STRAIGHT SCREW	TYPE	SCREWDRIVER
40.316.004.02-2	Hex. 1.25	43.601.104.01-2



## MULTI-UNIT

### STRAIGHT MULTI-UNIT

GH (mm)	NON ENGAGING
1	42.303.039.01-2



# COMPATIBLE WITH OO40

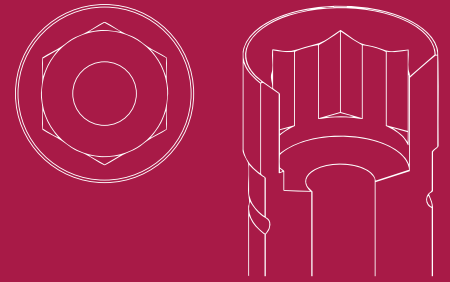

## LIST OF COMPATIBILITIES AVAILABLE

AB - ADIN - ALFA-GATE - ALPHABIO - ARDS - BIOHORIZONS - BIONER - BIOTEC - BTK - B&W - CORTEX - DITRON - DMI DENTAL SUPPLY  
 HI-TEC - IMPLANT DIRECT - IMPLANT GENESIS - INTRA-LOCK - JDENTALCARE - LEADER - MIS - NORIS MEDICAL - OSTEOPLUS  
 PROCLINIC - REFLECT - SOUTHERN IMPLANTS - TREE-OSS - TRI DENTAL IMPLANTS - VULKAN IMPLANTS - ZIACOM - ZIMMER

### STANDARD DYNAMIC TIBASE

GH (mm)	$\alpha_s$	$\alpha_c$	NON ENGAGING	ENGAGING
0,6	45°	30°	31.322.040.01-2	31.312.040.01-2 31.312.042.01-2 (Friction Fit)
1,5	25°	25°	31.322.040.02-2	31.312.040.02-2
3	20°	30°	31.322.040.03-2	31.312.040.03-2
4	15°	30°	31.322.040.04-2	31.312.040.04-2
5	10°	23°	31.322.040.05-2	31.312.040.05-2



### DYNAMIC 3TIBASE

GH (mm)	$\alpha_s$ CH=5mm	$\alpha_s$ CH=7mm	$\alpha_s$ CH=9mm	NON ENGAGING	ENGAGING
0,6	30°	25°	20°	31.322.040.21-2	31.312.040.21-2
1	30°	25°	20°	31.322.040.29-2	31.312.040.29-2
2	25°	20°	15°	-	31.312.040.28-2
3	25°	20°	15°	31.322.040.23-2	31.312.040.23-2



### DYNAMIC SCANBODY (LAB/CLIN)

H (mm)	SCANBODY	ADAPTOR	SCREWDRIVER ADAPTOR
8	52.408.101.01-2		
10	52.410.101.01-2	50.312.040.03-2 (IG=3mm)	43.621.410.01-2 43.624.410.01-2
12	52.412.101.01-2		



LIBRARY OPTIONS: GH = Gingival Height CH = Cement Height H = Height IG = Adaptor 3mm  $\alpha_s$  = Standard maximum angulation  $\alpha_c$  = Standard maximum angulation  $\alpha_d$  = Direct to implant maximum angulation

LAB SCANBODY	SCANALOG
30.412.001.01-2	23.412.040.01-2



### DYNAMIC MILLING TOOL

### ANALOG

SHANK	$\alpha_{di}$	DYNAMIC MILLING TOOL	ANALOG	DIGITAL ANALOG
3		33.370.716.01-2	22.612.040.01-2	34.612.040.01-2
4	25°	33.470.716.01-2		
6		33.670.716.01-2		



### SCANBODY OP

SCANBODY	PEEK	HEIGHT	TYPE	SCREWDRIVER
	49.414.000.01-2	6	A	
	49.415.000.01-2	9	A	
	49.416.000.01-2	13	A	
	49.414.000.02-2	6	B	
	49.415.000.02-2	9	B	
54.315.040.21-2	49.416.000.02-2	13	B	43.625.105.01-2
	49.414.000.03-2	6	C	
	49.415.000.03-2	9	C	
	49.416.000.03-2	13	C	
	49.416.000.04-2	13	D	
	49.416.000.05-2	13	E	



### SCREWS

DYNAMIC SCREW	HIGH	LENGTH	SCREWDRIVER
		18	43.618.201.01-2
41.317.071.01-2	41.317.106.01-2	24	43.624.201.01-2
		32	43.632.201.01-2



LIBRARY OPTIONS: GH = Gingival Height CH = Cement Height H = Height IG = Adaptor 3mm  $\alpha_s$  = Standard maximum angulation  $\alpha_d$  = Standard maximum angulation  $\alpha_i$  = Direct to implant maximum angulation

STRAIGHT SCREW	TYPE	SCREWDRIVER
40.317.004.01-2	Hex. 1.27	43.601.104.01-2



## MULTI-UNIT

### STRAIGHT MULTI-UNIT

GH (mm)	NON ENGAGING
1	42.302.040.01-2
2	42.302.040.02-2
3	42.302.040.03-2
4	42.302.040.04-2



### ANGULATED MULTI-UNIT 20°

GH (mm)	ENGAGING
2.5/3.9	48.312.040.02-2
3.5/4.9	48.312.040.03-2
4.5/5.9	48.312.040.04-2



### INTERNAL MULTI-UNIT

GH (mm)	NON ENGAGING
4	62.302.040.04-2



# COMPATIBLE WITH OO4OB

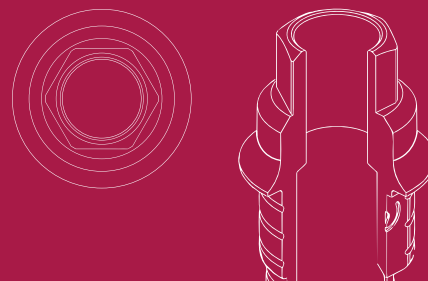

## LIST OF COMPATIBILITIES AVAILABLE

AVINENT - ECKERMANN - GMI (ILERIMPLANT) - MICRODENT - NORMON - NOVA IMPLANTS - PALTOP - RADHEX - RITTER WIN - ZIACOM

### STANDARD DYNAMIC TIBASE

GH (mm)	$\alpha_S$	$\alpha_C$	NON ENGAGING	ENGAGING
0,6	45°	30°	31.322.040.01-2	31.312.040.01-2 31.312.042.01-2 (Friction Fit)
1,5	25°	25°	31.322.040.02-2	31.312.040.02-2
3	20°	30°	31.322.040.03-2	31.312.040.03-2
4	15°	30°	31.322.040.04-2	31.312.040.04-2
5	10°	23°	31.322.040.05-2	31.312.040.05-2



### DYNAMIC 3TIBASE

GH (mm)	$\alpha_S$ CH=5mm	$\alpha_S$ CH=7mm	$\alpha_S$ CH=9mm	NON ENGAGING	ENGAGING
0,6	25°	20°	10°	31.322.040.21-2	31.312.040.21-2
1	30°	25°	20°	31.322.040.29-2	31.312.040.29-2
2	25°	20°	15°	-	31.312.040.28-2
3	25°	20°	15°	31.322.040.23-2	31.312.040.23-2



#### LAB SCANBODY

30.412.001.01-2



LIBRARY OPTIONS: GH = Gingival Height CH = Cement Height H = Height IG = Adaptor 3mm  $\alpha_S$  = Standard maximum angulation  $\alpha_C$  = Standard maximum angulation  $\alpha_D$  = Direct to implant maximum angulation

## SCREWS

DYNAMIC SCREW	LENGTH	SCREWDRIVER
	18	43.618.201.01-2
41.318.071.01-2	24	43.624.201.01-2
	32	43.632.201.01-2



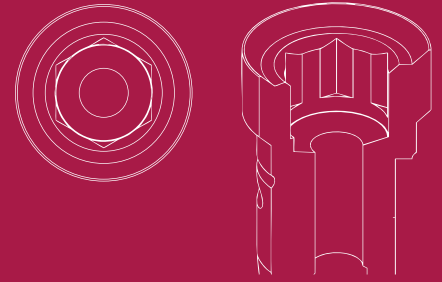

# COMPATIBLE WITH OO41

## LIST OF COMPATIBILITIES AVAILABLE

ACE - BIOHORIZONS - BIONER - DENTAL TECH - HI-TEC - IMPLANT DIRECT - INTRA-LOCK - MISS - PALTOP - REFLECT ZIACOM

### STANDARD DYNAMIC TIBASE

GH (mm)	$\alpha_s$	$\alpha_c$	NON ENGAGING	ENGAGING
0,4	45°	30°	31.323.041.01-2	31.323.041.02-2 31.313.043.01-2 (Friction Fit)
1,5	30°	25°	31.323.041.02-2	31.313.041.02-2



### DYNAMIC 3TIBASE

GH (mm)	$\alpha_s$ CH=5mm	$\alpha_s$ CH=7mm	$\alpha_s$ CH=9mm	NON ENGAGING	ENGAGING
0,4	30°	20°	10°	31.323.041.21-2	31.313.041.21-2
1,5	30°	25°	15°	31.323.041.22-2	31.313.041.22-2



### DYNAMIC SCANBODY (LAB/CLIN)

H (mm)	SCANBODY	ADAPTOR	SCREWDRIVER ADAPTOR
10	52.410.102.01-2	50.313.041.01-2	43.621.410.01-2
12	52.412.102.01-2	50.313.041.03-2 (IG=3mm)	43.624.410.01-2



LAB SCANBODY	SCANALOG
30.413.002.01-2	23.413.041.01-2



LIBRARY OPTIONS: GH = Gingival Height CH = Cement Height H = Height IG = Adaptor 3mm  $\alpha_s$  = Standard maximum angulation  $\alpha_c$  = Standard maximum angulation  $\alpha_d$  = Direct to implant maximum angulation

**DYNAMIC MILLING TOOL**

**ANALOG**

SHANK	$\alpha_{di}$	DYNAMIC MILLING TOOL	ANALOG	DIGITAL ANALOG
3		33.370.716.01-2	22.613.041.01-2	34.613.041.01-2
4	30°	33.470.716.01-2		
6		33.670.716.01-2		



**SCANBODY OP**

SCANBODY	PEEK PINS	HEIGHT	TYPE	SCREWDRIVER
54.315.041.21-2	49.414.000.01-2	6	A	43.625.105.01-2
	49.415.000.01-2	9	A	
	49.416.000.01-2	13	A	
	49.414.000.02-2	6	B	
	49.415.000.02-2	9	B	
	49.416.000.02-2	13	B	
	49.414.000.03-2	6	C	
	49.415.000.03-2	9	C	
	49.416.000.03-2	13	C	
	49.416.000.04-2	13	D	
	49.416.000.05-2	13	E	



**SCREWS**

DYNAMIC SCREW	HIGH	LENGTH	SCREWDRIVER
41.317.071.01-2	41.317.106.01-2	18	43.618.201.01-2
		24	43.624.201.01-2
		32	43.632.201.01-2



STRAIGHT SCREW	TYPE	SCREWDRIVER
40.317.004.01-2	Hex. 1.27	43.601.104.01-2



LIBRARY OPTIONS: GH = Gingival Height CH = Cement Height H = Height IG = Adaptor 3mm  $\alpha_s$  = Standard maximum angulation  $\alpha_c$  = Standard maximum angulation  $\alpha_d$  = Direct to implant maximum angulation

## MULTI-UNIT

### STRAIGHT MULTI-UNIT

GH (mm)	NON ENGAGING
1	42.303.041.01-2



# COMPATIBLE WITH OO41B

LIST OF COMPATIBILITIES **AVAILABLE**  
ECKERMANN - GMI (ILESIMPLANT) - RADHEX

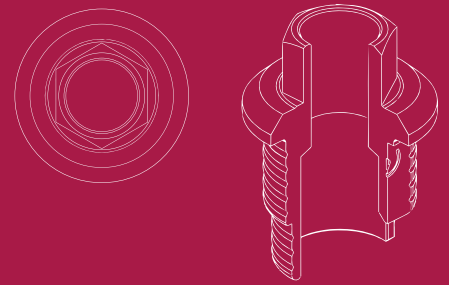

## STANDARD DYNAMIC TIBASE

GH (mm)	$\alpha_s$	$\alpha_c$	NON ENGAGING	ENGAGING
0,4	45°	30°	31.323.041.01-2	31.313.041.01-2
1,5	30°	25°	31.323.041.02-2	31.313.041.02-2



## DYNAMIC 3TIBASE

GH (mm)	$\alpha_s$ CH=5mm	$\alpha_s$ CH=7mm	$\alpha_s$ CH=9mm	NON ENGAGING	ENGAGING
0,4	30°	20°	10°	31.323.041.21-2	31.313.041.21-2
1,5	30°	25°	15°	31.323.041.22-2	31.313.041.22-2



### LAB SCANBODY

30.413.002.01-2



## DYNAMIC MILLING TOOL

SHANK	$\alpha_{di}$	DYNAMIC MILLING TOOL
3		33.370.716.01-2
4	30°	33.470.716.01-2
6		33.670.716.01-2



LIBRARY OPTIONS: GH = Gingival Height CH = Cement Height H = Height IG = Adaptor 3mm  $\alpha_s$  = Standard maximum angulation  $\alpha_c$  = Standard maximum angulation  $\alpha_{di}$  = Direct to implant maximum angulation

## SCREWS

DYNAMIC SCREW	LENTH	SCREWDRIVER
	18	43.618.201.01-2
41.318.071.01-2	24	43.624.201.01-2
	32	43.632.201.01-2



# COMPATIBLE WITH OO44

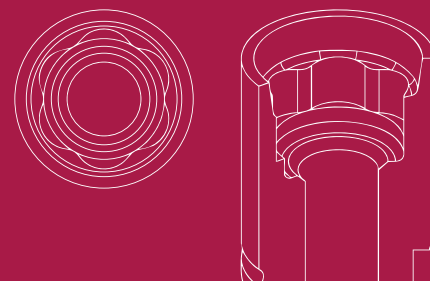

## LIST OF COMPATIBILITIES AVAILABLE KEYSTONE

### STANDARD DYNAMIC TIBASE

GH (mm)	$\alpha_s$	$\alpha_c$	NON ENGAGING	ENGAGING
1	42°	23°	31.322.044.01-2	31.312.044.01-2
2	25°	-	31.322.044.02-2	31.312.044.02-2



### DYNAMIC 3TIBASE

GH (mm)	$\alpha_s$ CH=5mm	$\alpha_s$ CH=7mm	$\alpha_s$ CH=9mm	NON ENGAGING	ENGAGING
1	25°	20°	10°	31.322.044.21-2	31.312.044.21-2



### DYNAMIC SCANBODY (LAB/CLIN)

H (mm)	SCANBODY	ADAPTOR	SCREWDRIVER ADAPTOR
10	52.410.105.01-2	50.312.044.01-2	43.621.410.01-2
12	52.412.105.01-2		43.624.410.01-2



LAB SCANBODY
30.412.001.01-2



LIBRARY OPTIONS: GH = Gingival Height CH = Cement Height H = Height IG = Adaptor 3mm  $\alpha_s$  = Standard maximum angulation  $\alpha_c$  = Standard maximum angulation  $\alpha_d$  = Direct to implant maximum angulation

## DYNAMIC MILLING TOOL

## ANALOG

SHANK	$\alpha_{di}$	DYNAMIC MILLING TOOL	DIGITAL ANALOG
3		33.390.716.01-2	34.612.044.01-2
4	25°	33.490.716.01-2	
6		33.690.716.01-2	



## SCREWS

DYNAMIC SCREW	LENGTH	SCREWDRIVER
41.318.065.01-2	18	43.618.201.01-2
	24	43.624.201.01-2
	32	43.632.201.01-2



STRAIGHT SCREW	TYPE	SCREWDRIVER
40.318.003.01-2	Hex. 1.20	43.601.103.02-2



# COMPATIBLE WITH OO45

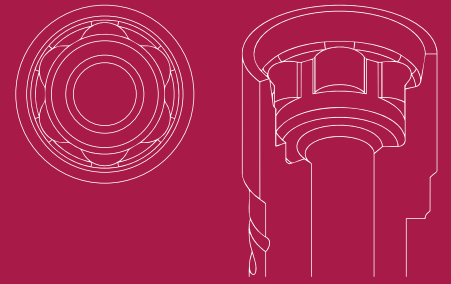

## LIST OF COMPATIBILITIES AVAILABLE KEYSTONE

### STANDARD DYNAMIC TIBASE

GH (mm)	$\alpha_s$	$\alpha_c$	NON ENGAGING	ENGAGING
1	43°	22°	31.323.045.01-2	31.313.045.01-2
2	25°	-	31.323.045.02-2	31.313.045.02-2



### DYNAMIC 3TIBASE

GH (mm)	$\alpha_s$ CH-5mm	$\alpha_s$ CH-7mm	$\alpha_s$ CH-9mm	NON ENGAGING	ENGAGING
1	25°	20°	10°	31.323.045.21-2	31.313.045.21-2



### DYNAMIC SCANBODY (LAB/CLIN)

H (mm)	SCANBODY	ADAPTOR	SCREWDRIVER ADAPTOR
10	52.410.118.01-2	50.313.045.01-2	43.621.410.01-2
12	52.412.118.01-2		43.624.410.01-2



LAB SCANBODY
30.413.002.01-2



LIBRARY OPTIONS: GH = Gingival Height CH = Cement Height H = Height IG = Adaptor 3mm  $\alpha_s$  = Standard maximum angulation  $\alpha_c$  = Standard maximum angulation  $\alpha_d$  = Direct to implant maximum angulation

### DYNAMIC MILLING TOOL

### ANALOG

SHANK	$\alpha_{di}$	DYNAMIC MILLING TOOL	DIGITAL ANALOG
3		33.390.716.01-2	34.613.045.01-2
4	30°	33.490.716.01-2	
6		33.690.716.01-2	



### SCREWS

DYNAMIC SCREW	LENGTH	SCREWDRIVER
41.318.065.01-2	18	43.618.201.01-2
	24	43.624.201.01-2
	32	43.632.201.01-2



STRAIGHT SCREW	TYPE	SCREWDRIVER
40.318.003.01-2	Hex. 1.20	43.601.103.02-2



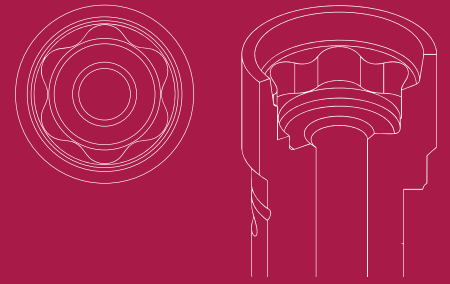

# COMPATIBLE WITH OO46

LIST OF COMPATIBILITIES **AVAILABLE**  
KEYSTONE

## STANDARD DYNAMIC TIBASE

GH (mm)	$\alpha_s$	$\alpha_c$	NON ENGAGING	ENGAGING
1	42°	21°	31.324.046.01-2	31.314.046.01-2



## DYNAMIC 3TIBASE

GH (mm)	$\alpha_s$ CH=5mm	$\alpha_s$ CH=7mm	$\alpha_s$ CH=9mm	NON ENGAGING	ENGAGING
1	30°	20°	10°	31.324.046.21-2	31.314.046.21-2



## DYNAMIC SCANBODY (LAB/CLIN)

H (mm)	SCANBODY	ADAPTOR	SCREWDRIVER ADAPTOR
10	52.410.125.01-2	50.314.046.01-2	43.621.410.01-2 43.624.410.01-2



### LAB SCANBODY

30.413.002.01-2



## DYNAMIC MILLING TOOL

SHANK	$\alpha_{di}$	DYNAMIC MILLING TOOL	DIGITAL ANALOG
3		33.390.716.01-2	34.614.046.01-2
4	30°	33.490.716.01-2	
6		33.690.716.01-2	

## ANALOG



LIBRARY OPTIONS: GH = Gingival Height CH = Cement Height H = Height IG = Adaptor 3mm  $\alpha_s$  = Standard maximum angulation  $\alpha_c$  = Standard maximum angulation  $\alpha_{di}$  = Direct to implant maximum angulation

## SCREWS

DYNAMIC SCREW	LENGTH	SCREWDRIVER
	18	43.618.201.01-2
41.318.065.01-2	24	43.624.201.01-2
	32	43.632.201.01-2



STRAIGHT SCREW	TYPE	SCREWDRIVER
40.318.003.01-2	Hex. 1.20	43.601.103.02-2



# COMPATIBLE WITH OO47

LIST OF COMPATIBILITIES **AVAILABLE**  
NEOSS

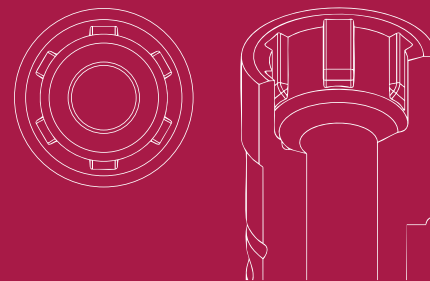

## STANDARD DYNAMIC TIBASE

GH (mm)	$\alpha_s$	$\alpha_c$	NON ENGAGING	ENGAGING
0,6	45°	30°	31.322.047.01-2	31.312.047.01-2



## DYNAMIC 3TIBASE

GH (mm)	$\alpha_s$ CH=5mm	$\alpha_s$ CH=7mm	$\alpha_s$ CH=9mm	NON ENGAGING	ENGAGING
0,6	30°	25°	20°	-	31.312.047.21-2



## DYNAMIC SCANBODY (LAB/CLIN)

H (mm)	SCANBODY	ADAPTOR	SCREWDRIVER ADAPTOR
9	52.409.123.01-2		
10	52.410.123.01-2	50.312.047.01-2	43.621.410.01-2 43.624.410.01-2
12	52.412.123.01-2		



### LAB SCANBODY

30.412.001.01-2



LIBRARY OPTIONS: GH = Gingival Height CH = Cement Height H = Height IG = Adaptor 3mm  $\alpha_s$  = Standard maximum angulation  $\alpha_c$  = Standard maximum angulation  $\alpha_d$  = Direct to implant maximum angulation

## DYNAMIC MILLING TOOL

## ANALOG

SHANK	$\alpha_{di}$	DYNAMIC MILLING TOOL	DIGITAL ANALOG
3		33.390.716.01-2	34.612.047.01-2
4	25°	33.490.716.01-2	
6		33.690.716.01-2	



## SCANBODY OP

SCANBODY	PEEK PINS	HEIGHT	TYPE	SCREWDRIVER
54.315.047.21-2	49.414.000.01-2	6	A	43.601.103.02-2
	49.415.000.01-2	9	A	
	49.416.000.01-2	13	A	
	49.414.000.02-2	6	B	
	49.415.000.02-2	9	B	
	49.416.000.02-2	13	B	
	49.414.000.03-2	6	C	
	49.415.000.03-2	9	C	
	49.416.000.03-2	13	C	
	49.416.000.04-2	13	D	
49.416.000.05-2	13	E		



## SCREWS

DYNAMIC SCREW	LENGTH	SCREWDRIVER
41.320.074.01-2	18	43.618.201.01-2
	24	43.624.201.01-2
	32	43.632.201.01-2



STRAIGHT SCREW	TYPE	SCREWDRIVER
40.320.007.02-2	TORX T6	43.601.107.01-2



LIBRARY OPTIONS: GH = Gingival Height CH = Cement Height H = Height IG = Adaptor 3mm  $\alpha_s$  = Standard maximum angulation  $\alpha_c$  = Standard maximum angulation  $\alpha_d$  = Direct to implant maximum angulation

# COMPATIBLE WITH OO48

## LIST OF COMPATIBILITIES AVAILABLE

NEOSS

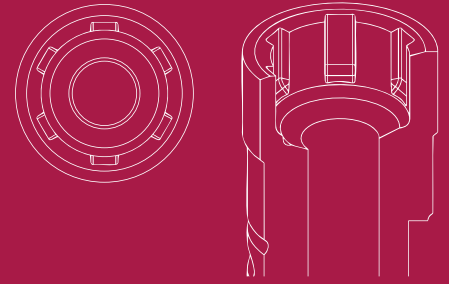

### STANDARD DYNAMIC TIBASE

GH (mm)	$\alpha_S$	$\alpha_C$	NON ENGAGING	ENGAGING
0,6	45°	30°	31.323.048.01-2	31.313.048.01-2



### DYNAMIC 3TIBASE

GH (mm)	$\alpha_S$ CH=5mm	$\alpha_S$ CH=7mm	$\alpha_S$ CH=9mm	NON ENGAGING	ENGAGING
0,6	30°	25°	20°	31.323.048.21-2	31.313.048.21-2



### DYNAMIC SCANBODY (LAB/CLIN)

H (mm)	SCANBODY	ADAPTOR	SCREWDRIVER ADAPTOR
9	52.409.123.01-2		
10	52.410.123.01-2	50.312.047.01-2	43.621.410.01-2 43.624.410.01-2
12	52.412.123.01-2		



LAB SCANBODY
30.413.002.01-2



LIBRARY OPTIONS: GH = Gingival Height CH = Cement Height H = Height IG = Adaptor 3mm  $\alpha_S$  = Standard maximum angulation  $\alpha_C$  = Standard maximum angulation  $\alpha_D$  = Direct to implant maximum angulation

## DYNAMIC MILLING TOOL

## ANALOG

SHANK	$\alpha_{di}$	DYNAMIC MILLING TOOL	DIGITAL ANALOG
3		33.390.716.01-2	34.612.047.01-2
4	30°	33.490.716.01-2	
6		33.690.716.01-2	



## SCREWS

DYNAMIC SCREW	LENGTH	SCREWDRIVER
41.320.074.01-2	18	43.618.201.01-2
	24	43.624.201.01-2
	32	43.632.201.01-2



STRAIGHT SCREW	TYPE	SCREWDRIVER
40.320.007.02-2	TORX T6	43.601.107.01-2



# COMPATIBLE WITH OO49

## LIST OF COMPATIBILITIES AVAILABLE

BEGO

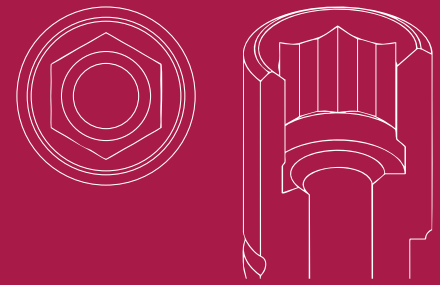

### STANDARD DYNAMIC TIBASE

GH (mm)	$\alpha_s$	$\alpha_c$	NON ENGAGING	ENGAGING
0,6	45°	30°	31.321.049.01-2	31.311.049.01-2



### DYNAMIC SCANBODY (LAB/CLIN)

H (mm)	SCANBODY	ADAPTOR	SCREWDRIVER ADAPTOR
10	52.410.116.01-2	50.311.049.01-2	43.621.410.01-2
12	52.412.116.01-2		43.624.410.01-2



#### LAB SCANBODY

30.412.001.01-2



### DYNAMIC MILLING TOOL

SHANK	$\alpha_{di}$	DYNAMIC MILLING TOOL	DIGITAL ANALOG
3		33.325.472.01-2*	34.611.049.01-2
4	25°	33.425.472.01-2*	
6		33.625.472.01-2*	

### ANALOG



\* Only for titanium and soft materials

LIBRARY OPTIONS: GH = Gingival Height CH = Cement Height H = Height IG = Adaptor 3mm  $\alpha_s$  = Standard maximum angulation  $\alpha_c$  = Standard maximum angulation  $\alpha_{di}$  = Direct to implant maximum angulation

## SCREWS

DYNAMIC SCREW	LENGTH	SCREWDRIVER
	18	43.618.201.01-2
41.314.064.01-2	24	43.624.201.01-2
	32	43.632.201.01-2



STRAIGHT SCREW	TYPE	SCREWDRIVER
40.314.004.01-2	Hex. 1.25	43.601.104.01-2



# COMPATIBLE WITH OO50

## LIST OF COMPATIBILITIES AVAILABLE

BEGO

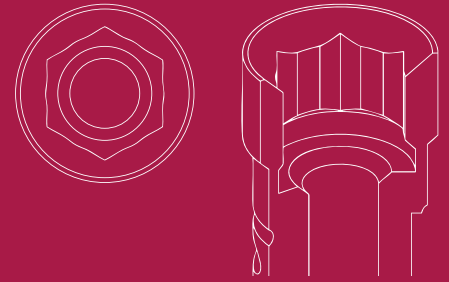

### STANDARD DYNAMIC TIBASE

GH (mm)	$\alpha_s$	$\alpha_c$	NON ENGAGING	ENGAGING
0,5	45°	27°	31.323.051.01-2	31.313.051.01-2
2	25°	-	31.323.051.03-2	31.313.051.03-2



### DYNAMIC 3TIBASE

GH (mm)	$\alpha_s$ CH=5mm	$\alpha_s$ CH=7mm	$\alpha_s$ CH=9mm	NON ENGAGING	ENGAGING
2	25°	20°	15°	31.323.051.23-2	31.313.051.23-2



### DYNAMIC SCANBODY (LAB/CLIN)

H (mm)	SCANBODY	ADAPTOR	SCREWDRIVER ADAPTOR
10	52.410.117.01-2		43.621.410.01-2
12	52.412.117.01-2	50.312.050.04-2 (IG=3mm)	43.624.410.01-2



LAB SCANBODY
30.412.001.01-2



LIBRARY OPTIONS: GH = Gingival Height CH = Cement Height H = Height IG = Adaptor 3mm  $\alpha_s$  = Standard maximum angulation  $\alpha_c$  = Standard maximum angulation  $\alpha_d$  = Direct to implant maximum angulation

## DYNAMIC MILLING TOOL

## ANALOG

SHANK	$\alpha_{di}$	DYNAMIC MILLING TOOL	DIGITAL ANALOG
3		33.335.676.01-2	34.612.050.01-2
4	25°	33.435.676.01-2	
6		33.635.676.01-2	



## SCREWS

DYNAMIC SCREW	LENGTH	SCREWDRIVER
	18	43.618.201.01-2
41.318.064.01-2	24	43.624.201.01-2
	32	43.632.201.01-2



STRAIGHT SCREW	TYPE	SCREWDRIVER
40.318.004.03-2	Hex. 1.25	43.601.104.01-2



## MULTI-UNIT

### STRAIGHT MULTI-UNIT

GH (mm)	NON ENGAGING
1	42.302.050.01-2
2	42.302.050.02-2



# COMPATIBLE WITH OO51

## LIST OF COMPATIBILITIES AVAILABLE

BEGO

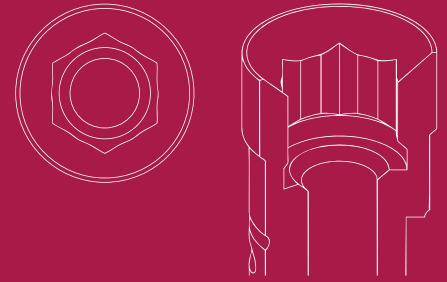

### STANDARD DYNAMIC TIBASE

GH (mm)	$\alpha_s$	$\alpha_c$	NON ENGAGING	ENGAGING
0,5	45°	25°	31.323.051.01-2	31.313.051.01-2
2	25°	-	31.323.051.03-2	31.313.051.03-2



### DYNAMIC 3TIBASE

GH (mm)	$\alpha_s$ CH=5mm	$\alpha_s$ CH=7mm	$\alpha_s$ CH=9mm	NON ENGAGING	ENGAGING
2	25°	20°	15°	31.323.051.23-2	31.313.051.23-2



### DYNAMIC SCANBODY (LAB/CLIN)

H (mm)	SCANBODY	ADAPTOR	SCREWDRIVER ADAPTOR
10	52.410.118.01-2	50.313.051.01-2	43.621.410.01-2
12	52.412.118.01-2	50.313.051.04-2 (IG=3mm)	43.624.410.01-2



#### LAB SCANBODY

30.412.001.01-2



LIBRARY OPTIONS: GH = Gingival Height CH = Cement Height H = Height IG = Adaptor 3mm  $\alpha_s$  = Standard maximum angulation  $\alpha_c$  = Standard maximum angulation  $\alpha_d$  = Direct to implant maximum angulation

## DYNAMIC MILLING TOOL

## ANALOG

SHANK	$\alpha_{di}$	DYNAMIC MILLING TOOL	DIGITAL ANALOG
3		33.335.676.01-2	34.613.051.01-2
4	25°	33.435.676.01-2	
6		33.635.676.01-2	



## SCREWS

DYNAMIC SCREW	LENGTH	SCREWDRIVER
	18	43.618.201.01-2
41.318.064.01-2	24	43.624.201.01-2
	32	43.632.201.01-2



STRAIGHT SCREW	TYPE	SCREWDRIVER
40.318.004.03-2	Hex. 1.25	43.601.104.01-2



# COMPATIBLE WITH OO52

## LIST OF COMPATIBILITIES AVAILABLE

BEGO

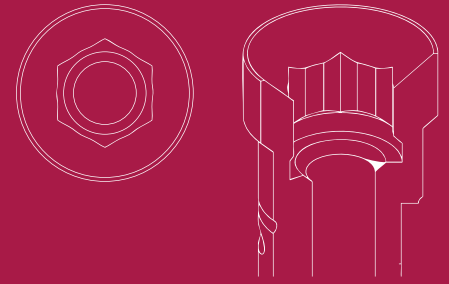

### STANDARD DYNAMIC TIBASE

GH (mm)	$\alpha_s$	$\alpha_c$	NON ENGAGING	ENGAGING
0,3	45°	27°	31.324.052.01-2	31.314.052.01-2



### DYNAMIC SCANBODY (LAB/CLIN)

H (mm)	SCANBODY	ADAPTOR	SCREWDRIVER ADAPTOR
10	52.410.102.01-2		43.621.410.01-2
12	52.412.102.01-2	50.314.052.04-2 (IG=3mm)	43.624.410.01-2



#### LAB SCANBODY

30.413.002.01-2



### DYNAMIC MILLING TOOL

SHANK	$\alpha_{di}$	DYNAMIC MILLING TOOL	DIGITAL ANALOG
3		33.335.676.01-2	34.614.052.01-2
4	30°	33.435.676.01-2	
6		33.635.676.01-2	

### ANALOG



LIBRARY OPTIONS: GH = Gingival Height CH = Cement Height H = Height IG = Adaptor 3mm  $\alpha_s$  = Standard maximum angulation  $\alpha_c$  = Standard maximum angulation  $\alpha_{di}$  = Direct to implant maximum angulation

## SCREWS

DYNAMIC SCREW	LENGTH	SCREWDRIVER
	18	43.618.201.01-2
41.318.064.01-2	24	43.624.201.01-2
	32	43.632.201.01-2



STRAIGHT SCREW	TYPE	SCREWDRIVER
40.318.004.03-2	Hex. 1.25	43.601.104.01-2



# COMPATIBLE WITH OO54

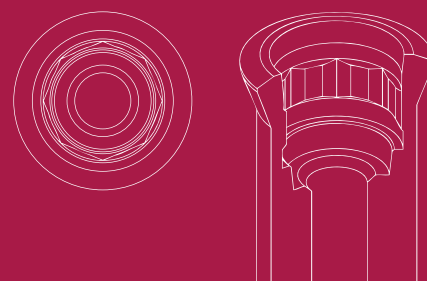

## LIST OF COMPATIBILITIES AVAILABLE

KLOCKNER

### STANDARD DYNAMIC TIBASE

GH (mm)	$\alpha_s$	$\alpha_c$	NON ENGAGING	ENGAGING
0,6	45°	25°	31.323.054.01-2	31.313.054.01-2



### DYNAMIC SCANBODY (LAB/CLIN)

H (mm)	SCANBODY	ADAPTOR	SCREWDRIVER ADAPTOR
10	52.410.119.01-2	50.314.054.01-2	43.621.410.01-2
12	52.412.119.01-2		43.624.410.01-2



#### LAB SCANBODY

30.413.002.01-2



### DYNAMIC MILLING TOOL

SHANK	$\alpha_{di}$	DYNAMIC MILLING TOOL	DIGITAL ANALOG
3		33.345.856.01-2	34.614.054.01-2
4	30°	33.445.856.01-2	
6		33.645.856.01-2	

### ANALOG



LIBRARY OPTIONS: GH = Gingival Height CH = Cement Height H = Height IG = Adaptor 3mm  $\alpha_s$  = Standard maximum angulation  $\alpha_c$  = Standard maximum angulation  $\alpha_{di}$  = Direct to implant maximum angulation

SCREWS

DYNAMIC SCREW	LENGTH	SCREWDRIVER
	18	43.618.201.01-2
41.318.067.01-2	24	43.624.201.01-2
	32	43.632.201.01-2



STRAIGHT SCREW

40.318.012.01-2



# COMPATIBLE WITH OO57

LIST OF COMPATIBILITIES **AVAILABLE**  
BIOMET 3L

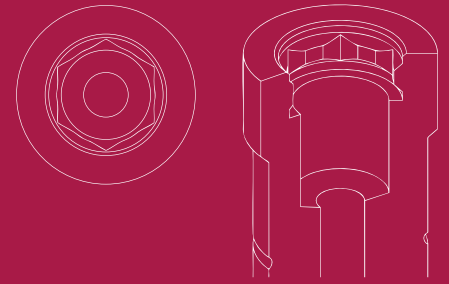

## STANDARD DYNAMIC TIBASE

GH (mm)	$\alpha_s$	$\alpha_c$	NON ENGAGING	ENGAGING
0,5	45°	27°	31.324.057.01-2	31.314.057.01-2



## DYNAMIC SCANBODY (LAB/CLIN)

H (mm)	SCANBODY	ADAPTOR	SCREWDRIVER ADAPTOR
8	52.408.101.01-2		
10	52.410.101.01-2	50.314.057.01-2	43.621.410.01-2 43.624.410.01-2
12	52.412.101.01-2		



### LAB SCANBODY

30.414.003.01-2



## DYNAMIC MILLING TOOL

SHANK	$\alpha_{di}$	DYNAMIC MILLING TOOL	ANALOG	DIGITAL ANALOG
3		33.390.805.01-2	22.614.057.01-2	34.614.057.01-2
4	30°	33.490.805.01-2		
6		33.690.805.01-2		



LIBRARY OPTIONS: GH = Gingival Height CH = Cement Height H = Height IG = Adaptor 3mm  $\alpha_s$  = Standard maximum angulation  $\alpha_c$  = Standard maximum angulation  $\alpha_{di}$  = Direct to implant maximum angulation

## SCREWS

DYNAMIC SCREW	LENGTH	SCREWDRIVER
	18	43.618.201.01-2
41.316.084.01-2	24	43.624.201.01-2
	32	43.632.201.01-2



STRAIGHT SCREW	TYPE	SCREWDRIVER
40.316.003.01-2	Hex. 1.20	43.601.103.02-2



# COMPATIBLE WITH 0058

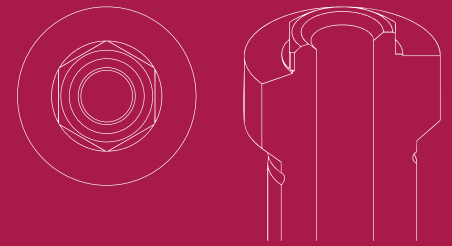

## LIST OF COMPATIBILITIES **AVAILABLE**

ACE - ANTHOGRYR - B&W - BIOGENESIS - BIOMET 3L - BIONER - EASY IMPLANT - LEADER - MEGAGEN - MICRODENT  
MISS - MPI - OSSTEM IMPLANT - PROCLINIC - SIN IMPLANTS - SOUTHERN IMPLANTS - TBR

### STANDARD DYNAMIC TIBASE

GH (mm)	$\alpha_s$	$\alpha_c$	NON ENGAGING	ENGAGING
0,5	45°	30°	31.324.058.01-2	31.314.058.01-2



### DYNAMIC SCANBODY (LAB/CLIN)

H (mm)	SCANBODY	ADAPTOR	SCREWDRIVER ADAPTOR
10	52.410.118.01-2	50.314.058.01-2	43.621.410.01-2
12	52.412.118.01-2		43.624.410.01-2



#### LAB SCANBODY

30.414.003.01-2



### DYNAMIC MILLING TOOL

SHANK	$\alpha_{di}$	DYNAMIC MILLING TOOL	ANALOG	DIGITAL ANALOG
3	30°	33.390.716.01-2	22.614.058.01-2	34.614.058.01-2
4		33.490.716.01-2		
6		33.690.716.01-2		



**LIBRARY OPTIONS:** GH = Gingival Height CH = Cement Height H = Height IG = Adaptor 3mm  $\alpha_s$  = Standard maximum angulation  $\alpha_c$  = Standard maximum angulation  $\alpha_{di}$  = Direct to implant maximum angulation

## SCREWS

DYNAMIC SCREW	LENGTH	SCREWDRIVER
	18	43.618.201.01-2
41.320.047.01-2	24	43.624.201.01-2
	32	43.632.201.01-2



STRAIGHT SCREW	TYPE	SCREWDRIVER
40.320.003.02-2	Hex. 1.20	43.601.103.02-2



# COMPATIBLE WITH OO59

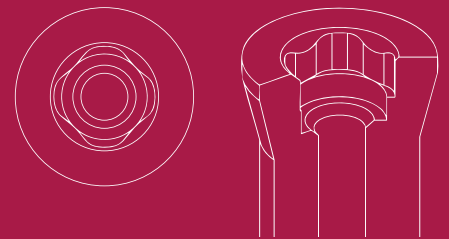

## LIST OF COMPATIBILITIES AVAILABLE

BTI

### STANDARD DYNAMIC TIBASE

GH (mm)	$\alpha_s$	$\alpha_c$	NON ENGAGING	ENGAGING
0,7	45°	27°	31.324.059.01-2	31.314.059.01-2



### DYNAMIC SCANBODY (LAB/CLIN)

H (mm)	SCANBODY	ADAPTOR	SCREWDRIVER ADAPTOR
10	52.410.115.01-2	50.313.010.01-2	43.621.410.01-2
12	52.412.115.01-2	50.313.010.04-2 (IG=3mm)	43.624.410.01-2



#### LAB SCANBODY

30.414.003.01-2



### DYNAMIC MILLING TOOL

SHANK	$\alpha_{di}$	DYNAMIC MILLING TOOL	ANALOG
3		33.390.716.01-2	22.614.059.01-2
4	30°	33.490.716.01-2	
6		33.690.716.01-2	



LIBRARY OPTIONS: GH = Gingival Height CH = Cement Height H = Height IG = Adaptor 3mm  $\alpha_s$  = Standard maximum angulation  $\alpha_c$  = Standard maximum angulation  $\alpha_{di}$  = Direct to implant maximum angulation

## SCREWS

DYNAMIC SCREW	LENGTH	SCREWDRIVER
	18	43.618.201.01-2
41.318.065.01-2	24	43.624.201.01-2
	32	43.632.201.01-2



STRAIGHT SCREW	TYPE	SCREWDRIVER
40.318.003.01-2	Hex. 1.20	43.601.103.02-2



# COMPATIBLE WITH OO60

## LIST OF COMPATIBILITIES AVAILABLE

BTI - PHIBO

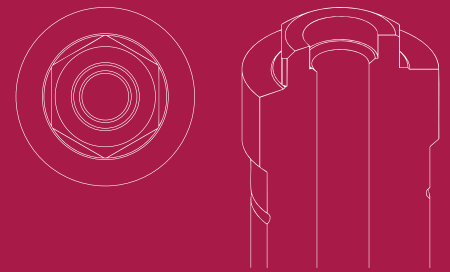

### STANDARD DYNAMIC TIBASE

GH (mm)	$\alpha_s$	$\alpha_c$	NON ENGAGING	ENGAGING
0,5	45°	30°	31.324.060.01-2	31.314.060.01-2



### DYNAMIC SCANBODY (LAB/CLIN)

H (mm)	SCANBODY	ADAPTOR	SCREWDRIVER ADAPTOR
10	52.410.122.01-2	50.314.060.01-2	43.621.410.01-2 43.624.410.01-2



#### LAB SCANBODY

30.415.007.01-2



### DYNAMIC MILLING TOOL

SHANK	$\alpha_{di}$	DYNAMIC MILLING TOOL
3		33.390.716.01-2
4	30°	33.490.716.01-2
6		33.690.716.01-2

### ANALOG

ANALOG	DIGITAL ANALOG
22.614.060.01-2	34.614.060.01-2



LIBRARY OPTIONS: GH = Gingival Height CH = Cement Height H = Height IG = Adaptor 3mm  $\alpha_s$  = Standard maximum angulation  $\alpha_c$  = Standard maximum angulation  $\alpha_{di}$  = Direct to implant maximum angulation

## SCREWS

DYNAMIC SCREW	LENGTH	SCREWDRIVER
	18	43.618.201.01-2
41.320.060.01-2	24	43.624.201.01-2
	32	43.632.201.01-2



STRAIGHT SCREW	TYPE	SCREWDRIVER
40.320.003.01-2	Hex. 1.20	43.601.103.02-2



# COMPATIBLE WITH OO61

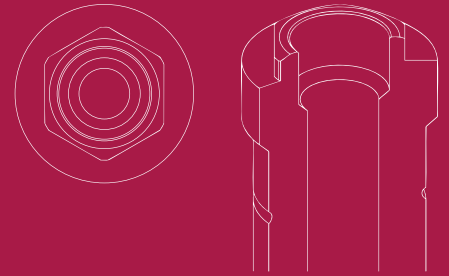

## LIST OF COMPATIBILITIES **AVAILABLE**

AVINENT - COLLELMEDI - DENTIS - DIO IMPLANTS - GMI (ILERIMPLANT) - GT MEDICAL - KEYSTONE - KLOCKNER  
MOZO-GRAU (TICARE) - NOBEL BIOCARE - OSSTEM IMPLANT - TREE-OSS

### STANDARD DYNAMIC TIBASE

GH (mm)	$\alpha_s$	$\alpha_c$	NON ENGAGING	ENGAGING
0,6	45°	30°	31.324.061.01-2	31.314.061.01-2



### DYNAMIC SCANBODY (LAB/CLIN)

H (mm)	SCANBODY	ADAPTOR	SCREWDRIVER ADAPTOR
10	52.410.125.01-2	50.314.061.01-2	43.621.410.01-2 43.624.410.01-2



#### LAB SCANBODY

30.415.007.01-2
-----------------



### DYNAMIC MILLING TOOL

SHANK	$\alpha_{di}$	DYNAMIC MILLING TOOL	ANALOG	DIGITAL ANALOG
3		33.390.958.01-2	22.614.061.01-2	34.614.061.01-2
4	30°	33.490.958.01-2		
6		33.690.958.01-2		



LIBRARY OPTIONS: GH = Gingival Height CH = Cement Height H = Height IG = Adaptor 3mm  $\alpha_s$  = Standard maximum angulation  $\alpha_c$  = Standard maximum angulation  $\alpha_{di}$  = Direct to implant maximum angulation

## SCREWS

DYNAMIC SCREW	LENGTH	SCREWDRIVER
	18	43.618.201.01-2
41.325.067.01-2	24	43.624.201.01-2
	32	43.632.201.01-2



STRAIGHT SCREW	TYPE	SCREWDRIVER
40.325.008.01-2	UNIGRIP	43.625.108.01-2



# COMPATIBLE WITH OO66

## LIST OF COMPATIBILITIES AVAILABLE

ASTRA

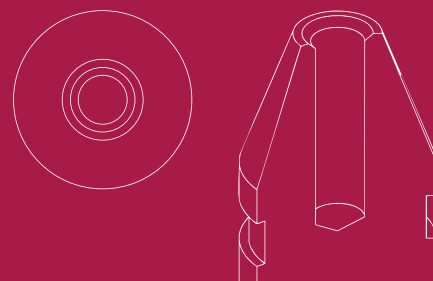

### STANDARD DYNAMIC TIBASE

GH (mm)	$\alpha_s$	$\alpha_c$	NON ENGAGING	ENGAGING
0,6	45°	30°	31.323.066.01-2	-

#### LAB SCANBODY

30.412.001.01-2



### ANALOG

#### ANALOG

22.614.066.01-2



### SCREWS

DYNAMIC SCREW	LENGTH	SCREWDRIVER
	18	43.618.201.01-2
41.314.039.01-2	24	43.624.201.01-2
	32	43.632.201.01-2



STRAIGHT SCREW	TYPE	SCREWDRIVER
40.314.008.01-2	UNIGRIP	43.625.108.01-2



LIBRARY OPTIONS: GH = Gingival Height CH = Cement Height H = Height IG = Adaptor 3mm  $\alpha_s$  = Standard maximum angulation  $\alpha_c$  = Standard maximum angulation  $\alpha_d$  = Direct to implant maximum angulation

# COMPATIBLE WITH OO74

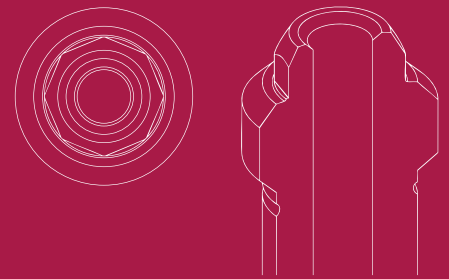

## LIST OF COMPATIBILITIES **AVAILABLE**

ANTHOGYR - DENTIUM - DIO IMPLANTS - EUROTEKNIKA - GT MEDICAL - IMPLANT DIRECT - MEGAGEN - PROCLINIC  
STRAUMANN - TRINON - ZIACOM

### STANDARD DYNAMIC TIBASE

GH (mm)	$\alpha_s$	$\alpha_c$	NON ENGAGING	ENGAGING
0,6	45°	30°	31.323.074.01-2	31.313.074.01-2



### DYNAMIC SCANBODY (LAB/CLIN)

H (mm)	SCANBODY	ADAPTOR	SCREWDRIVER ADAPTOR
8	52.408.110.01-2		
10	52.410.110.01-2	50.313.074.01-2	43.621.410.01-2 43.624.410.01-2
12	52.412.110.01-2		



LAB SCANBODY	SCANALOG
30.415.007.01-2	23.413.074.01-2



### DYNAMIC MILLING TOOL

SHANK	$\alpha_{di}$	DYNAMIC MILLING TOOL	ANALOG	DIGITAL ANALOG
3		33.330.708.01-2	22.613.074.01-2	34.613.074.01-2
4	30°	33.430.708.01-2		
6		33.630.708.01-2		



### ANALOG

LIBRARY OPTIONS: GH = Gingival Height CH = Cement Height H = Height IG = Adaptor 3mm  $\alpha_s$  = Standard maximum angulation  $\alpha_c$  = Standard maximum angulation  $\alpha_{di}$  = Direct to implant maximum angulation

## SCANBODY REFERENCE

SCANBODY	PEEK PINS	HEIGHT	TYPE	SCREWDRIVER
54.322.074.31-2	49.414.000.01-2	6	A	43.601.103.02-2
	49.415.000.01-2	9	A	
	49.416.000.01-2	13	A	
	49.414.000.02-2	6	B	
	49.415.000.02-2	9	B	
	49.416.000.02-2	13	B	
	49.414.000.03-2	6	C	
	49.415.000.03-2	9	C	
	49.416.000.03-2	13	C	
	49.416.000.04-2	13	D	
	49.416.000.05-2	13	E	
CAPS		HEIGHT	TYPE	
	49.418.000.01-2	3,8	Regular	
	49.418.000.02-2	3,8	Wide	
	49.419.000.01-2	6	Regular	
	49.419.000.02-2	6	Wide	
	49.420.000.01-2	8	Regular	
	49.420.000.02-2	8	Wide	



## SCREWS

DYNAMIC SCREW	LENGTH	SCREWDRIVER
41.320.044.01-2	18	43.618.201.01-2
	24	43.624.201.01-2
	32	43.632.201.01-2
STRAIGHT SCREW	TYPE	SCREWDRIVER
40.320.007.04-2	TORX T6	43.601.107.01-2



LIBRARY OPTIONS: GH = Gingival Height CH = Cement Height H = Height IG = Adaptor 3mm Gs = Standard maximum angulation Gc = Standard maximum angulation Gd = Direct to implant maximum angulation

# COMPATIBLE WITH 0075

LIST OF COMPATIBILITIES **AVAILABLE**  
ANKLYOS

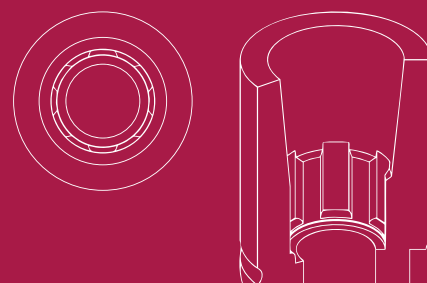

## STANDARD DYNAMIC TIBASE

GH (mm)	$\alpha_s$	$\alpha_c$	NON ENGAGING	ENGAGING
1	42°	24°	31.322.075.01-2	-
2	20°	15°	31.322.075.02-2	31.312.075.02-2
3	20°	-	31.322.075.03-2	31.312.075.03-2
4	15°	-	31.322.075.04-2	31.312.075.04-2



## DYNAMIC 3TIBASE

GH (mm)	$\alpha_s$ CH-5mm	$\alpha_s$ CH-7mm	$\alpha_s$ CH-9mm	NON ENGAGING	ENGAGING
1	30°	20°	15°	31.322.075.21-2	-



## DYNAMIC SCANBODY (LAB/CLIN)

H (mm)	SCANBODY	ADAPTOR	SCREWDRIVER ADAPTOR
10	52.410.105.01-2		43.621.410.01-2
12	52.412.105.01-2	50.312.075.03-2 (IG=3mm)	43.624.410.01-2



### LAB SCANBODY

30.412.001.01-2



LIBRARY OPTIONS: GH = Gingival Height CH = Cement Height H = Height IG = Adaptor 3mm  $\alpha_s$  = Standard maximum angulation  $\alpha_c$  = Standard maximum angulation  $\alpha_d$  = Direct to implant maximum angulation

## DYNAMIC MILLING TOOL

## ANALOG

SHANK	$\alpha_{di}$	DYNAMIC MILLING TOOL	ANALOG	DIGITAL ANALOG
3		33.330.734.01-2	22.612.075.01-2	34.612.075.01-2
4	25°	33.430.734.01-2		
6		33.630.734.01-2		



## SCANBODY OP

SCANBODY	PEEK PINS	HEIGHT	TYPE
54.315.075.21-2	49.414.000.01-2	6	A
	49.415.000.01-2	9	A
	49.416.000.01-2	13	A
	49.414.000.02-2	6	B
	49.415.000.02-2	9	B
	49.416.000.02-2	13	B
	49.414.000.03-2	6	C
	49.415.000.03-2	9	C
	49.416.000.03-2	13	C
	49.416.000.04-2	13	D
49.416.000.05-2	13	E	



## SCREWS

DYNAMIC SCREW	LENGTH	SCREWDRIVER
41.318.077.01-2	18	43.618.201.01-2
	24	43.624.201.01-2
	32	43.632.201.01-2



## STRAIGHT SCREW

40.318.013.01-2



## MULTI-UNIT

### STRAIGHT MULTI-UNIT

GH (mm)	ENGAGING
2	42.302.075.02-2
3	42.302.075.03-2
4	42.302.075.04-2



# COMPATIBLE WITH OO80

## LIST OF COMPATIBILITIES **AVAILABLE**

BIOHORIZONS - ZIACON - ZIMMER

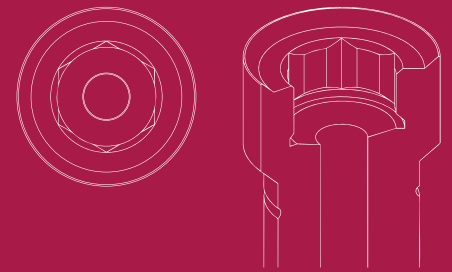

### STANDARD DYNAMIC TIBASE

GH (mm)	$\alpha_s$	$\alpha_c$	NON ENGAGING	ENGAGING
0,4	45°	30°	31.324.080.01-2	31.314.080.01-2



### DYNAMIC SCANBODY (LAB/CLIN)

H (mm)	SCANBODY	ADAPTOR	SCREWDRIVER ADAPTOR
10	52.410.124.01-2	50.314.080.01-2	43.621.410.01-2
12	52.412.124.01-2		43.624.410.01-2



#### LAB SCANBODY

30.414.003.01-2



### DYNAMIC MILLING TOOL

SHANK	$\alpha_{di}$	DYNAMIC MILLING TOOL
3	30°	33.370.716.01-2
4		33.470.716.01-2
6		33.670.716.01-2

### ANALOG

ANALOG	DIGITAL ANALOG
22.614.080.01-2	34.614.080.01-2



LIBRARY OPTIONS: GH = Gingival Height CH = Cement Height H = Height IG = Adaptor 3mm  $\alpha_s$  = Standard maximum angulation  $\alpha_c$  = Standard maximum angulation  $\alpha_{di}$  = Direct to implant maximum angulation

## SCANBODY OP

SCANBODY	PEEK PINS	HEIGHT	TYPE	SCREWDRIVER
54.315.080.21-2	49.414.000.01-2	6	A	43.601.104.01-2
	49.415.000.01-2	9	A	
	49.416.000.01-2	13	A	
	49.414.000.02-2	6	B	
	49.415.000.02-2	9	B	
	49.416.000.02-2	13	B	
	49.414.000.03-2	6	C	
	49.415.000.03-2	9	C	
	49.416.000.03-2	13	C	
	49.416.000.04-2	13	D	
49.416.000.05-2	13	E		



## SCREWS

DYNAMIC SCREW	LENGTH	SCREWDRIVER
41.317.071.01-2	18	43.618.201.01-2
	24	43.624.201.01-2
	32	43.632.201.01-2



STRAIGHT SCREW	TYPE	SCREWDRIVER
40.317.004.01-2	Hex. 1.27	43.601.104.01-2



LIBRARY OPTIONS: GH = Gingival Height CH = Cement Height H = Height IG = Adaptor 3mm αs = Standard maximum angulation αc = Standard maximum angulation αd = Direct to implant maximum angulation

# COMPATIBLE WITH OO81

## LIST OF COMPATIBILITIES AVAILABLE

BEGO

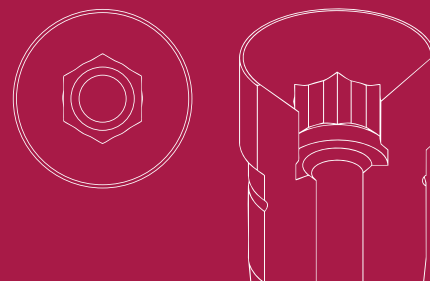

### STANDARD DYNAMIC TIBASE

GH (mm)	$\alpha_s$	$\alpha_c$	NON ENGAGING	ENGAGING
0,4	41°	18°	31.325.081.01-2	31.315.081.01-2



### DYNAMIC SCANBODY (LAB/CLIN)

H (mm)	SCANBODY	ADAPTOR	SCREWDRIVER ADAPTOR
10	52.410.126.01-2	50.315.081.01-2	43.621.410.01-2
12	52.412.126.01-2		43.624.410.01-2



#### LAB SCANBODY

30.414.003.01-2



### DYNAMIC MILLING TOOL

SHANK	$\alpha_{di}$	DYNAMIC MILLING TOOL	DIGITAL ANALOG
3		33.335.676.01-2	34.615.081.01 -2
4	30°	33.435.676.01-2	
6		33.635.676.01-2	

### ANALOG



LIBRARY OPTIONS: GH = Gingival Height CH = Cement Height H = Height IG = Adaptor 3mm  $\alpha_s$  = Standard maximum angulation  $\alpha_c$  = Standard maximum angulation  $\alpha_{di}$  = Direct to implant maximum angulation

## SCREWS

DYNAMIC SCREW	LENGTH	SCREWDRIVER
	18	43.618.201.01-2
41.318.064.01-2	24	43.624.201.01-2
	32	43.632.201.01-2



STRAIGHT SCREW	TYPE	SCREWDRIVER
40.318.004.03-2	Hex. 1.25	43.601.104.01-2



# COMPATIBLE WITH OO82

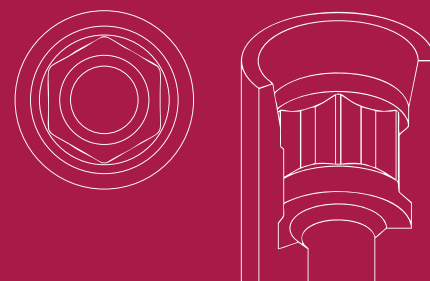

## LIST OF COMPATIBILITIES AVAILABLE

KLOCKNER

### STANDARD DYNAMIC TIBASE

GH (mm)	$\alpha_s$	$\alpha_c$	NON ENGAGING	ENGAGING
1,2	45°	25°	31.322.082.01-2	31.312.082.01-2



### DYNAMIC SCANBODY (LAB/CLIN)

H (mm)	SCANBODY	ADAPTOR	SCREWDRIVER ADAPTOR
10	52.410.105.01-2	50.312.082.01-2	43.621.410.01-2
12	52.412.105.01-2		43.624.410.01-2



#### LAB SCANBODY

30.412.001.01-2



### DYNAMIC MILLING TOOL

SHANK	$\alpha_{di}$	DYNAMIC MILLING TOOL
3		33.345.804.01-2
4	25°	33.445.804.01-2
6		33.645.804.01-2

### ANALOG

DIGITAL ANALOG
34.612.082.01-2



LIBRARY OPTIONS: GH = Gingival Height CH = Cement Height H = Height IG = Adaptor 3mm  $\alpha_s$  = Standard maximum angulation  $\alpha_c$  = Standard maximum angulation  $\alpha_{di}$  = Direct to implant maximum angulation

## SCREWS

DYNAMIC SCREW	LENGTH	SCREWDRIVER
	18	43.618.201.01-2
41.316.074.01-2	24	43.624.201.01-2
	32	43.632.201.01-2



### STRAIGHT SCREW

40.316.012.01-2



## MULTI-UNIT

### STRAIGHT MULTI-UNIT

GH (mm)	NON ENGAGING
1	42.302.082.01-2
2	42.302.082.02-2
3	42.302.082.03-2
4	42.302.082.04-2



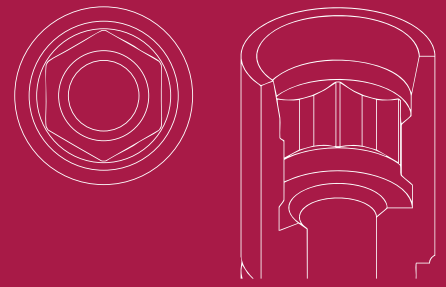

# COMPATIBLE WITH 0083

## LIST OF COMPATIBILITIES AVAILABLE

KLOCKNER

### STANDARD DYNAMIC TIBASE

GH (mm)	$\alpha_s$	$\alpha_c$	NON ENGAGING	ENGAGING
1,2	45°	25°	31.323.083.01-2	31.313.083.01-2



### DYNAMIC SCANBODY (LAB/CLIN)

H (mm)	SCANBODY	ADAPTOR	SCREWDRIVER ADAPTOR
10	52.410.103.01-2	50.313.083.01-2	43.621.410.01-2
12	52.412.103.01-2		43.624.410.01-2



#### LAB SCANBODY

30.413.002.01-2



### DYNAMIC MILLING TOOL

SHANK	$\alpha_{di}$	DYNAMIC MILLING TOOL	DIGITAL ANALOG
3	30°	33.345.856.01-2	34.613.083.01-2
4		33.445.856.01-2	
6		33.645.856.01-2	

### ANALOG



LIBRARY OPTIONS: GH = Gingival Height CH = Cement Height H = Height IG = Adaptor 3mm  $\alpha_s$  = Standard maximum angulation  $\alpha_c$  = Standard maximum angulation  $\alpha_{di}$  = Direct to implant maximum angulation

## SCREWS

DYNAMIC SCREW	LENGTH	SCREWDRIVER
	18	43.618.201.01-2
41.318.076.01-2	24	43.624.201.01-2
	32	43.632.201.01-2



### STRAIGHT SCREW

40.318.012.02-2



## MULTI-UNIT

### STRAIGHT MULTI-UNIT

GH (mm)	NON ENGAGING
1	42.303.083.01-2
2	42.303.083.02-2
3	42.303.083.03-2
4	42.303.083.04-2



# COMPATIBLE WITH OO84

LIST OF COMPATIBILITIES **AVAILABLE**  
XIVE

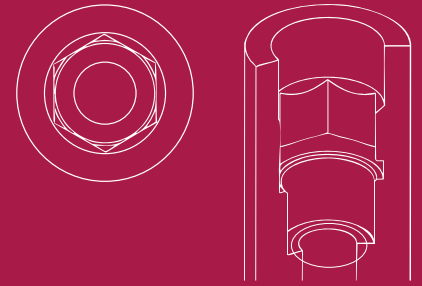

## STANDARD DYNAMIC TIBASE

GH (mm)	$\alpha_s$	$\alpha_c$	NON ENGAGING	ENGAGING
1	40°	-	31.321.084.01	31.311.084.01-2
<b>LAB SCANBODY</b>				
30.410.006.01-2				



## SCREWS

DYNAMIC SCREW	LENGTH	SCREWDRIVER
	18	43.618.201.01-2
41.314.076.01-2	24	43.624.201.01-2
	32	43.632.201.01-2

STRAIGHT SCREW	TYPE	SCREWDRIVER
40.314.003.03-2	Hex. 1.20	43.601.103.02-2



LIBRARY OPTIONS: GH = Gingival Height CH = Cement Height H = Height IG = Adaptor 3mm  $\alpha_s$  = Standard maximum angulation  $\alpha_c$  = Standard maximum angulation  $\alpha_d$  = Direct to implant maximum angulation

# COMPATIBLE WITH OO85

## LIST OF COMPATIBILITIES AVAILABLE

XIVE

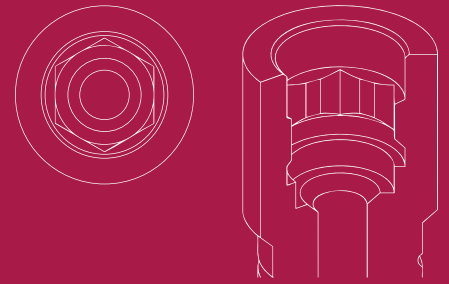

### STANDARD DYNAMIC TIBASE

GH (mm)	$\alpha_S$	$\alpha_C$	NON ENGAGING	ENGAGING
0,3	45°	30°	31.324.085.01-2	31.314.085.01-2



### DYNAMIC 3TIBASE

GH (mm)	$\alpha_S$ CH=5mm	$\alpha_S$ CH=7mm	$\alpha_S$ CH=9mm	NON ENGAGING	ENGAGING
0,3	30°	25°	20°	-	31.314.085.21-2



### DYNAMIC SCANBODY (LAB/CLIN)

H (mm)	SCANBODY	ADAPTOR	SCREWDRIVER ADAPTOR
10	52.410.117.01-2	50.314.085.01-2	43.621.410.01-2
12	52.412.117.01-2		43.624.410.01-2



#### LAB SCANBODY

30.413.002.01-2



LIBRARY OPTIONS: GH = Gingival Height CH = Cement Height H = Height IG = Adaptor 3mm  $\alpha_S$  = Standard maximum angulation  $\alpha_C$  = Standard maximum angulation  $\alpha_D$  = Direct to implant maximum angulation

### DYNAMIC MILLING TOOL

### ANALOG

SHANK	$\alpha_{di}$	DYNAMIC MILLING TOOL	DIGITAL ANALOG
3		33.345.856.01-2	34.614.085.01-2
4	25°	33.445.856.01-2	
6		33.645.856.01-2	



### SCREWS

DYNAMIC SCREW	LENGTH	SCREWDRIVER
	18	43.618.201.01-2
41.316.081.01-2	24	43.624.201.01-2
	32	43.632.201.01-2



STRAIGHT SCREW	TYPE	SCREWDRIVER
40.316.004.02-2	Hex. 1.25	43.601.104.01-2



LIBRARY OPTIONS: GH = Gingival Height CH = Cement Height H = Height IG = Adaptor 3mm  $\alpha_s$  = Standard maximum angulation  $\alpha_c$  = Standard maximum angulation  $\alpha_d$  = Direct to implant maximum angulation

# COMPATIBLE WITH 0086

## LIST OF COMPATIBILITIES AVAILABLE

XIVE

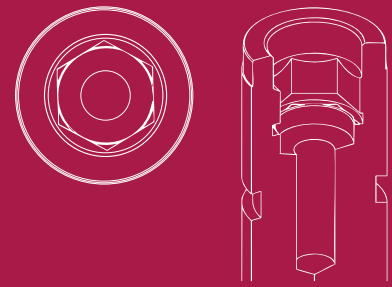

### STANDARD DYNAMIC TIBASE

GH (mm)	$\alpha_s$	$\alpha_c$	NON ENGAGING	ENGAGING
1	45°	-	31.325.086.01-2	31.315.086.01-2



### DYNAMIC SCANBODY (LAB/CLIN)

H (mm)	SCANBODY	ADAPTOR	SCREWDRIVER ADAPTOR
10	52.410.117.01-2	50.314.085.01-2	43.621.410.01-2
12	52.412.117.01-2		43.624.410.01-2



#### LAB SCANBODY

30.415.007.01-2



### DYNAMIC MILLING TOOL

SHANK	$\alpha_{di}$	DYNAMIC MILLING TOOL
3		33.345.856.01-2
4	25°	33.445.856.01-2
6		33.645.856.01-2



LIBRARY OPTIONS: GH = Gingival Height CH = Cement Height H = Height IG = Adaptor 3mm  $\alpha_s$  = Standard maximum angulation  $\alpha_c$  = Standard maximum angulation  $\alpha_{di}$  = Direct to implant maximum angulation

## SCREWS

DYNAMIC SCREW	LENGTH	SCREWDRIVER
	18	43.618.201.01-2
41.316.081.01-2	24	43.624.201.01-2
	32	43.632.201.01-2



STRAIGHT SCREW	TYPE	SCREWDRIVER
40.316.004.02-2	Hex. 1.25	43.601.104.01-2



# COMPATIBLE WITH 0087

## LIST OF COMPATIBILITIES AVAILABLE

CAMLOG

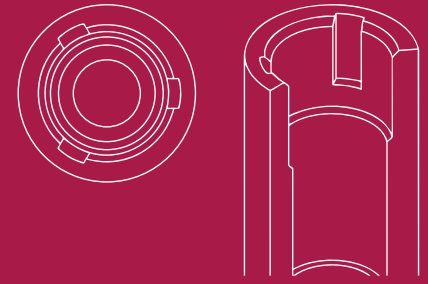

### STANDARD DYNAMIC TIBASE

GH (mm)	$\alpha_s$	$\alpha_c$	NON ENGAGING	ENGAGING
0,3	25°	-	31.321.087.01-2	31.311.087.01-2



### DYNAMIC 3TIBASE

GH (mm)	$\alpha_s$ CH=5mm	$\alpha_s$ CH=7mm	$\alpha_s$ CH=9mm	NON ENGAGING	ENGAGING
0,3	20°	20°	15°	-	31.311.087.21-2
2	25°	20°	15°	-	31.311.087.23-2



### DYNAMIC SCANBODY (LAB/CLIN)

H (mm)	SCANBODY	ADAPTOR	SCREWDRIVER ADAPTOR
10	52.410.132.01-2		
12	52.412.132.01-2	50.311.087.04-2 (IG=3mm)	43.621.415.01-2



#### LAB SCANBODY

30.410.006.01-2



LIBRARY OPTIONS: GH = Gingival Height CH = Cement Height H = Height IG = Adaptor 3mm  $\alpha_s$  = Standard maximum angulation  $\alpha_c$  = Standard maximum angulation  $\alpha_d$  = Direct to implant maximum angulation

## SCANBODY OP

SCANBODY	PEEK PINS	HEIGHT	TYPE	SCREWDRIVER
54.315.087.21-2	49.414.000.01-2	6	A	43.625.105.01-2
	49.415.000.01-2	9	A	
	49.416.000.01-2	13	A	
	49.414.000.02-2	6	B	
	49.415.000.02-2	9	B	
	49.416.000.02-2	13	B	
	49.414.000.03-2	6	C	
	49.415.000.03-2	9	C	
	49.416.000.03-2	13	C	
	49.416.000.04-2	13	D	
49.416.000.05-2	13	E		



## SCREWS

DYNAMIC SCREW	LENGTH	SCREWDRIVER
41.316.094.01-2	18	43.618.201.01-2
	24	43.624.201.01-2
	32	43.632.201.01-2



STRAIGHT SCREW	TYPE	SCREWDRIVER
40.316.005.04-2	Hex. 1.27	43.625.105.01-2



LIBRARY OPTIONS: GH = Gingival Height CH = Cement Height H = Height IG = Adaptor 3mm αs = Standard maximum angulation αc = Standard maximum angulation αd = Direct to implant maximum angulation

# COMPATIBLE WITH OO88

## LIST OF COMPATIBILITIES AVAILABLE

CAMLOG

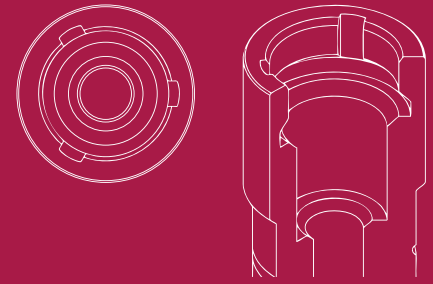

### STANDARD DYNAMIC TIBASE

GH (mm)	$\alpha_s$	$\alpha_c$	NON ENGAGING	ENGAGING
0,3	25°	-	31.324.088.01-2	31.314.088.01-2
<b>LAB SCANBODY</b>				
30.414.003.01-2				



### SCANBODY OP

SCANBODY	PEEK PINS	HEIGHT	TYPE	SCREWDRIVER
54.315.088.21-2	49.414.000.01-2	6	A	43.625.105.01-2
	49.415.000.01-2	9	A	
	49.416.000.01-2	13	A	
	49.414.000.02-2	6	B	
	49.415.000.02-2	9	B	
	49.416.000.02-2	13	B	
	49.414.000.03-2	6	C	
	49.415.000.03-2	9	C	
	49.416.000.03-2	13	C	
	49.416.000.04-2	13	D	
49.416.000.05-2	13	E		



LIBRARY OPTIONS: GH = Gingival Height CH = Cement Height H = Height IG = Adaptor 3mm  $\alpha_s$  = Standard maximum angulation  $\alpha_c$  = Standard maximum angulation  $\alpha_d$  = Direct to implant maximum angulation

## SCREWS

DYNAMIC SCREW	LENGTH	SCREWDRIVER
	18	43.618.201.01-2
41.320.094.01-2	24	43.624.201.01-2
	32	43.632.201.01-2



STRAIGHT SCREW	TYPE	SCREWDRIVER
40.320.005.04-2	Hex. 1.27	43.625.105.01-2



# COMPATIBLE WITH 0090

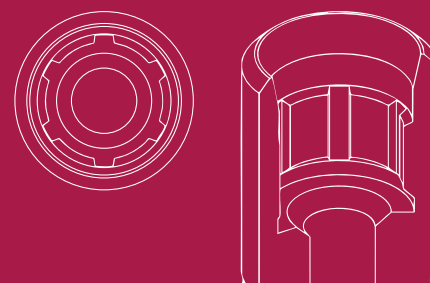

## LIST OF COMPATIBILITIES AVAILABLE

ASTRA

### STANDARD DYNAMIC TIBASE

GH (mm)	$\alpha_s$	$\alpha_c$	NON ENGAGING	ENGAGING
1	45°	24°	31.321.090.01-2	31.311.090.01-2
2	25°	-	31.321.090.02-2	31.311.090.02-2
3	20°	-	31.321.091.03-2	31.311.090.03-2



### DYNAMIC 3TIBASE

GH (mm)	$\alpha_s$ CH-5mm	$\alpha_s$ CH-7mm	$\alpha_s$ CH-9mm	NON ENGAGING	ENGAGING
1	30°	25°	15°	-	31.311.090.21-2



### DYNAMIC SCANBODY (LAB/CLIN)

H (mm)	SCANBODY	ADAPTOR	SCREWDRIVER ADAPTOR
10	52.410.128.01-2	50.311.090.03-2 (IG=3mm)	43.621.415.01-2



#### LAB SCANBODY

30.410.006.01-2



LIBRARY OPTIONS: GH = Gingival Height CH = Cement Height H = Height IG = Adaptor 3mm  $\alpha_s$  = Standard maximum angulation  $\alpha_c$  = Standard maximum angulation  $\alpha_d$  = Direct to implant maximum angulation

## DYNAMIC MILLING TOOL

## ANALOG

SHANK	$\alpha_{di}$	DYNAMIC MILLING TOOL	DIGITAL ANALOG
3		33.325.472.01-2*	34.611.090.01-2
4	25°	33.425.472.01-2*	
6		33.625.472.01-2*	



\*Only for R  
\*Only for titanium and soft materials

## SCANBODY OP

SCANBODY	PEEK PINS	HEIGHT	TYPE	SCREWDRIVER
54.315.090.21-2	49.414.000.01-2	6	A	43.625.105.01-2
	49.415.000.01-2	9	A	
	49.416.000.01-2	13	A	
	49.414.000.02-2	6	B	
	49.415.000.02-2	9	B	
	49.416.000.02-2	13	B	
	49.414.000.03-2	6	C	
	49.415.000.03-2	9	C	
	49.416.000.03-2	13	C	
	49.416.000.04-2	13	D	
49.416.000.05-2	13	E		



## SCREWS

DYNAMIC SCREW	LENGTH	SCREWDRIVER
41.314.074.01-2	18	43.618.201.01-2
	24	43.624.201.01-2
	32	43.632.201.01-2

STRAIGHT SCREW	TYPE	SCREWDRIVER
40.314.005.01-2	Hex. 1.27	43.625.105.01-2



LIBRARY OPTIONS: GH = Gingival Height CH = Cement Height H = Height IG = Adaptor 3mm ds = Standard maximum angulation ds = Standard maximum angulation ds = Direct to implant maximum angulation

# COMPATIBLE WITH 0091

LIST OF COMPATIBILITIES **AVAILABLE**  
ASTRA

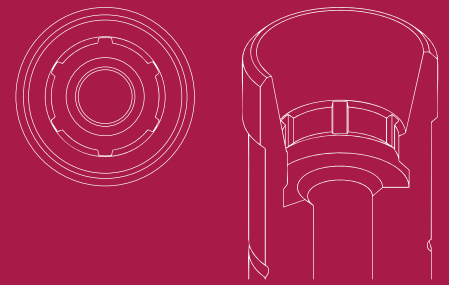

## STANDARD DYNAMIC TIBASE

GH (mm)	$\alpha_s$	$\alpha_c$	NON ENGAGING	ENGAGING
1,2	38°	18°	31.324.091.01-2	31.314.091.01-2
2	25°	-	31.324.091.02-2	31.314.091.02-2
3	20°	25°	31.324.091.03-2	31.314.091.03-2
4	15°	25°	31.324.091.04-2	31.314.091.04-2



## DYNAMIC 3TIBASE

GH (mm)	$\alpha_s$ CH=5mm	$\alpha_s$ CH=7mm	$\alpha_s$ CH=9mm	NON ENGAGING	ENGAGING
1,2	30°	25°	15°	-	31.314.091.21-2



## DYNAMIC SCANBODY (LAB/CLIN)

H (mm)	SCANBODY	ADAPTOR	SCREWDRIVER ADAPTOR
10	52.410.102.01-2		43.621.410.01-2
12	52.412.102.01-2	50.314.091.03-2 (IG=3mm)	43.624.410.01-2



### LAB SCANBODY

30.413.002.01-2



LIBRARY OPTIONS: GH = Gingival Height CH = Cement Height H = Height IG = Adaptor 3mm  $\alpha_s$  = Standard maximum angulation  $\alpha_c$  = Standard maximum angulation  $\alpha_d$  = Direct to implant maximum angulation

**DYNAMIC MILLING TOOL**

**ANALOG**

SHANK	$\alpha_{di}$	DYNAMIC MILLING TOOL	DIGITAL ANALOG
3		33.390.958.01-2	34.614.091.01-2
4	30°	33.490.958.01-2	
6		33.690.958.01-2	



**SCANBODY OP**

SCANBODY	PEEK PINS	HEIGHT	TYPE	SCREWDRIVER
54.315.091.21-2	49.414.000.01-2	6	A	43.625.105.01-2
	49.415.000.01-2	9	A	
	49.416.000.01-2	13	A	
	49.414.000.02-2	6	B	
	49.415.000.02-2	9	B	
	49.416.000.02-2	13	B	
	49.414.000.03-2	6	C	
	49.415.000.03-2	9	C	
	49.416.000.03-2	13	C	
	49.416.000.04-2	13	D	
49.416.000.05-2	13	E		



**SCREWS**

DYNAMIC SCREW	HIGH	LENGTH	SCREWDRIVER
41.320.074.01-2	41.320.129.01-2	18	43.618.201.01-2
		24	43.624.201.01-2
		32	43.632.201.01-2



STRAIGHT SCREW	TYPE	SCREWDRIVER
40.320.005.01-2	Hex. 1.27	43.625.105.01-2



LIBRARY OPTIONS: GH = Gingival Height CH = Cement Height H = Height IG = Adaptor 3mm  $\alpha_s$  = Standard maximum angulation  $\alpha_d$  = Standard maximum angulation  $\alpha_{di}$  = Direct to implant maximum angulation

## MULTI-UNIT

### STRAIGHT MULTI-UNIT

GH (mm)	ENGAGING
1	42.303.091.01-2
2	42.303.091.02-2
3	42.303.091.03-2
4	42.303.091.04-2



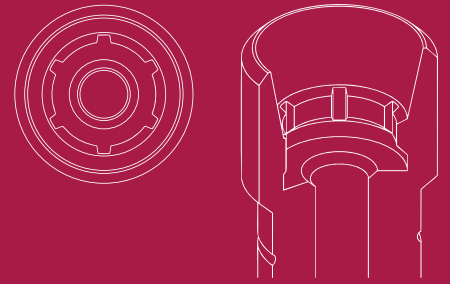

# COMPATIBLE WITH OO92

## LIST OF COMPATIBILITIES AVAILABLE

ASTRA

### STANDARD DYNAMIC TIBASE

GH (mm)	$\alpha_s$	$\alpha_c$	NON ENGAGING	ENGAGING
1	45°	25°	31.325.092.01-2	31.315.092.01-2
2	25°	-	31.325.092.02-2	31.315.092.02-2
3	20°	-	31.325.092.03-2	31.315.092.03-2



### DYNAMIC 3TIBASE

GH (mm)	$\alpha_s$ CH=5mm	$\alpha_s$ CH=7mm	$\alpha_s$ CH=9mm	NON ENGAGING	ENGAGING
1	30°	25°	15°	-	31.315.092.21-2



### DYNAMIC SCANBODY (LAB/CLIN)

H (mm)	SCANBODY	ADAPTOR	SCREWDRIVER ADAPTOR
10	52.410.129.01-2	50.315.092.01-2 50.315.092.03-2 (IG=3mm)	43.621.410.01-2 43.624.410.01-2



#### LAB SCANBODY

30.415.007.01-2



LIBRARY OPTIONS: GH = Gingival Height CH = Cement Height H = Height IG = Adaptor 3mm  $\alpha_s$  = Standard maximum angulation  $\alpha_c$  = Standard maximum angulation  $\alpha_d$  = Direct to implant maximum angulation

## DYNAMIC MILLING TOOL

## ANALOG

SHANK	$\alpha_{di}$	DYNAMIC MILLING TOOL	DIGITAL ANALOG
3		33.390.958.01-2	34.615.092.01-2
4	30°	33.490.958.01-2	
6		33.690.958.01-2	



## SCANBODY OP

SCANBODY	PEEK PINS	HEIGHT	TYPE	SCREWDRIVER
54.315.092.21-2	49.414.000.01-2	6	A	43.625.105.01-2
	49.415.000.01-2	9	A	
	49.416.000.01-2	13	A	
	49.414.000.02-2	6	B	
	49.415.000.02-2	9	B	
	49.416.000.02-2	13	B	
	49.414.000.03-2	6	C	
	49.415.000.03-2	9	C	
	49.416.000.03-2	13	C	
	49.416.000.04-2	13	D	
49.416.000.05-2	13	E		



## SCREWS

DYNAMIC SCREW	LENGTH	SCREWDRIVER
41.320.074.01-2	18	43.618.201.01-2
	24	43.624.201.01-2
	32	43.632.201.01-2

STRAIGHT SCREW	TYPE	SCREWDRIVER
40.320.005.01-2	Hex. 1.27	43.625.105.01-2



LIBRARY OPTIONS: GH = Gingival Height CH = Cement Height H = Height IG = Adaptor 3mm  $\alpha_s$  = Standard maximum angulation  $\alpha_c$  = Standard maximum angulation  $\alpha_d$  = Direct to implant maximum angulation

# COMPATIBLE WITH 0096

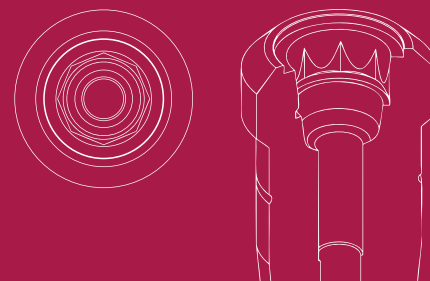

## LIST OF COMPATIBILITIES **AVAILABLE**

ACE - ANTHOGRYR - DENTIUM - EUROTEKNIKA - IMPLANT DIRECT - PROCLINIC - SOUTHERN IMPLANTS - STRAUMANN

### STANDARD DYNAMIC TIBASE

GH (mm)	$\alpha_s$	$\alpha_c$	NON ENGAGING	ENGAGING
0,6	45°	30°	31.324.096.01-2	31.314.096.01-2



LAB SCANBODY	SCANALOG
30.414.008.01-2	23.414.096.01-2



### DYNAMIC MILLING TOOL

SHANK	$\alpha_{di}$	DYNAMIC MILLING TOOL
3		33.315.708.01-2
4	30°	33.415.708.01-2
6		33.615.708.01-2

### ANALOG

ANALOG	DIGITAL ANALOG
22.614.096.01-2	34.614.096.01-2



LIBRARY OPTIONS: GH = Gingival Height CH = Cement Height H = Height IG = Adaptor 3mm  $\alpha_s$  = Standard maximum angulation  $\alpha_c$  = Standard maximum angulation  $\alpha_{di}$  = Direct to implant maximum angulation

## SCANBODY OP

SCANBODY	PEEK PINS	HEIGHT	TYPE	SCREWDRIVER
54.315.096.21-2	49.414.000.01-2	6	A	43.601.107.01-2
	49.415.000.01-2	9	A	
	49.416.000.01-2	13	A	
	49.414.000.02-2	6	B	
	49.415.000.02-2	9	B	
	49.416.000.02-2	13	B	
	49.414.000.03-2	6	C	
	49.415.000.03-2	9	C	
	49.416.000.03-2	13	C	
	49.416.000.04-2	13	D	
49.416.000.05-2	13	E		



## SCREWS

DYNAMIC SCREW	LENGTH	SCREWDRIVER
41.320.067.01-2	18	43.618.201.01-2
	24	43.624.201.01-2
	32	43.632.201.01-2



STRAIGHT SCREW	TYPE	SCREWDRIVER
40.320.007.01-2	TORX T6	43.601.107.01-2



LIBRARY OPTIONS: GH - Gingival Height CH - Cement Height H - Height IG - Adaptor 3mm αs - Standard maximum angulation αc - Standard maximum angulation αd - Direct to implant maximum angulation

# COMPATIBLE WITH 0101

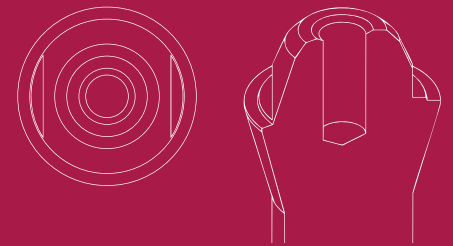

## LIST OF COMPATIBILITIES **AVAILABLE** STRAUMANN

### STANDARD DYNAMIC TIBASE

GH (mm)	$\alpha_s$	$\alpha_c$	NON ENGAGING	ENGAGING
0,5	45°	30°	31.323.101.01-2	-



### DYNAMIC SCANBODY (LAB/CLIN)

H (mm)	SCANBODY	ADAPTOR	SCREWDRIVER ADAPTOR
9	52.409.133.01-2	50.313.101.01-2	43.621.410.01-2 43.624.410.01-2



LAB SCANBODY	MINI SCANBODY	SCANALOG
30.413.005.01-2	53.413.101.01-2	23.413.101.01-2



### DYNAMIC MILLING TOOL

SHANK	$\alpha_{di}$	DYNAMIC MILLING TOOL	DIGITAL ANALOG
3		33.335.676.01-2	34.613.101.01-2
4	30°	33.435.676.01-2	
6		33.635.676.01-2	

### ANALOG



LIBRARY OPTIONS: GH = Gingival Height CH = Cement Height H = Height IG = Adaptor 3mm  $\alpha_s$  = Standard maximum angulation  $\alpha_c$  = Standard maximum angulation  $\alpha_{di}$  = Direct to implant maximum angulation

### SCANBODY REFERENCE

SCANBODY	PEEK PINS	HEIGHT	TYPE	SCREWDRIVER
54.322.101.31-2	49.414.000.01-2	6	A	43.601.107.01-2
	49.415.000.01-2	9	A	
	49.416.000.01-2	13	A	
	49.414.000.02-2	6	B	
	49.415.000.02-2	9	B	
	49.416.000.02-2	13	B	
	49.414.000.03-2	6	C	
	49.415.000.03-2	9	C	
	49.416.000.03-2	13	C	
	49.416.000.04-2	13	D	
49.416.000.05-2	13	E		
	CAPS	HEIGHT	TYPE	
	49.418.000.01-2	3,8	Regular	
	49.418.000.02-2	3,8	Wide	
	49.419.000.01-2	6	Regular	
	49.419.000.02-2	6	Wide	
	49.420.000.01-2	8	Regular	
	49.420.000.02-2	8	Wide	



### SCREWS

DYNAMIC SCREW	HIGH	LENGTH	SCREWDRIVER
41.314.043.01-2	41.314.050.31-2	18	43.618.201.01-2
		24	43.624.201.01-2
		32	43.632.201.01-2



STRAIGHT SCREW	TYPE	SCREWDRIVER
40.314.007.01-2	TORX T6	43.601.107.01-2



LIBRARY OPTIONS: GH = Gingival Height CH = Cement Height H = Height IG = Adaptor 3mm Gs = Standard maximum angulation Gc = Standard maximum angulation Gd = Direct to implant maximum angulation

# COMPATIBLE WITH O102

LIST OF COMPATIBILITIES **AVAILABLE**  
BIOHORIZONS

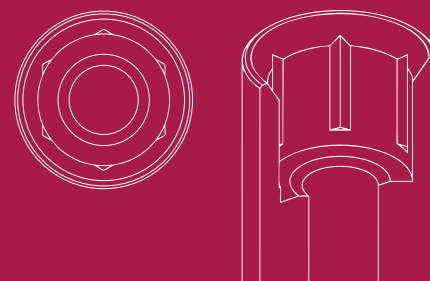

## STANDARD DYNAMIC TIBASE

GH (mm)	$\alpha_S$	$\alpha_C$	NON ENGAGING	ENGAGING
1,8	38°	18°	31.322.102.01-2	31.312.102.01-2



## DYNAMIC 3TIBASE

GH (mm)	$\alpha_S$ CH=5mm	$\alpha_S$ CH=7mm	$\alpha_S$ CH=9mm	NON ENGAGING	ENGAGING
1	30°	25°	20°	31.322.102.29-2	31.312.102.29-2
1,8	25°	15°	10°	31.322.102.21-2	31.312.102.21-2
3	20°	20°	15°	31.322.102.23-2	31.312.102.23-2



## DYNAMIC SCANBODY (LAB/CLIN)

H (mm)	SCANBODY	ADAPTOR	SCREWDRIVER ADAPTOR
10	52.410.128.01-2	50.312.102.03-2 (IG=3mm)	43.621.415.01-2



LAB SCANBODY	SCANALOG
30.412.001.01-2	23.412.102.01-2



LIBRARY OPTIONS: GH = Gingival Height CH = Cement Height H = Height IG = Adaptor 3mm  $\alpha_S$  = Standard maximum angulation  $\alpha_C$  = Standard maximum angulation  $\alpha_D$  = Direct to implant maximum angulation

### DYNAMIC MILLING TOOL

### ANALOG

SHANK	$\alpha_{di}$	DYNAMIC MILLING TOOL	DIGITAL ANALOG
3		33.345.856.01-2	34.612.102.01-2
4	25°	33.445.856.01-2	
6		33.635.856.01-2	



### SCANBODY OP

SCANBODY	PEEK PINS	HEIGHT	TYPE	SCREWDRIVER
54.315.102.21-2	49.414.000.01-2	6	A	43.625.105.01-2
	49.415.000.01-2	9	A	
	49.416.000.01-2	13	A	
	49.414.000.02-2	6	B	
	49.415.000.02-2	9	B	
	49.416.000.02-2	13	B	
	49.414.000.03-2	6	C	
	49.415.000.03-2	9	C	
	49.416.000.03-2	13	C	
	49.416.000.04-2	13	D	
	49.416.000.05-2	13	E	



### SCREWS

DYNAMIC SCREW	LENGTH	SCREWDRIVER
41.317.065.01-2	18	43.618.201.01-2
	24	43.624.201.01-2
	32	43.632.201.01-2



STRAIGHT SCREW	TYPE	SCREWDRIVER
40.317.005.02-2	Hex. 1.27	43.625.105.01-2



LIBRARY OPTIONS: GH = Gingival Height CH = Cement Height H = Height IG = Adaptor 3mm  $\alpha_s$  = Standard maximum angulation  $\alpha_i$  = Standard maximum angulation  $\alpha_d$  = Direct to implant maximum angulation

## MULTI-UNIT

### STRAIGHT MULTI-UNIT

GH (mm)	NON ENGAGING
1	42.302.102.01-2
2	42.302.102.02-2
3	42.302.102.03-2
4	42.302.102.04-2



### ANGULATED MULTI-UNIT 20°

GH (mm)	ENGAGING
2,5/3,9	48.312.102.02-2



# COMPATIBLE WITH O109

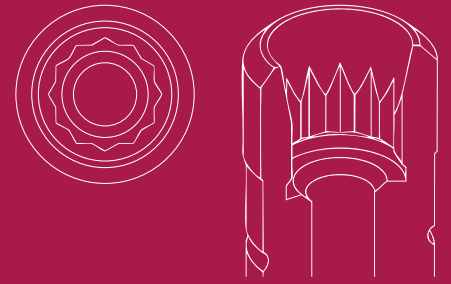

## LIST OF COMPATIBILITIES **AVAILABLE**

ASTRA - CORTEX - MOZO-GRAU (TICARE) - SOUTHERN IMPLANTS

### STANDARD DYNAMIC TIBASE

GH (mm)	$\alpha_s$	$\alpha_c$	NON ENGAGING	ENGAGING
1,2	45°	29°	31.322.109.01-2	31.312.109.01-2



### DYNAMIC SCANBODY (LAB/CLIN)

H (mm)	SCANBODY	ADAPTOR	SCREWDRIVER ADAPTOR
10	52.410.128.01-2	50.312.109.01-2	43.621.415.01-2



#### LAB SCANBODY

30.412.001.01-2



### DYNAMIC MILLING TOOL

SHANK	$\alpha_{di}$	DYNAMIC MILLING TOOL	DIGITAL ANALOG	ANALOG
3		33.360.754.01-2*	34.612.109.01-2	22.612.109.01-2
4	25°	33.460.754.01-2*		
6		33.660.754.01-2*		



\*Only for R

LIBRARY OPTIONS: GH = Gingival Height CH = Cement Height H = Height IG = Adaptor 3mm  $\alpha_s$  = Standard maximum angulation  $\alpha_c$  = Standard maximum angulation  $\alpha_{di}$  = Direct to implant maximum angulation

## SCREWS

DYNAMIC SCREW	LENGTH	SCREWDRIVER
	18	43.618.201.01-2
41.314.070.01-2	24	43.624.201.01-2
	32	43.632.201.01-2



STRAIGHT SCREW	TYPE	SCREWDRIVER
40.314.005.02-2	Hex. 1.27	43.625.105.01-2



# COMPATIBLE WITH O110

LIST OF COMPATIBILITIES **AVAILABLE**  
BREDENT MEDICAL

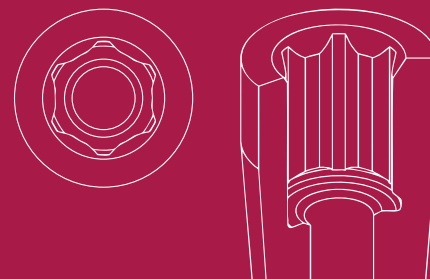

## STANDARD DYNAMIC TIBASE

GH (mm)	$\alpha_s$	$\alpha_c$	NON ENGAGING	ENGAGING
0,4	45°	30°	31.320.110.01-2	31.312.110.01-2



## DYNAMIC SCANBODY (LAB/CLIN)

H (mm)	SCANBODY	ADAPTOR	SCREWDRIVER ADAPTOR
10	52.410.117.01-2		43.621.410.01-2
12	52.412.117.01-2	50.310.110.04-2 (IG=3mm)	43.624.410.01-2



### LAB SCANBODY

30.410.006.01-2



## DYNAMIC MILLING TOOL

SHANK	$\alpha_{di}$	DYNAMIC MILLING TOOL	DIGITAL ANALOG
3		33.360.756.01-2*	34.610.110.01-2
4	20°	33.460.756.01-2*	
6		33.660.756.01-2*	



LIBRARY OPTIONS: GH - Gingival height CB - Cervical height H - Height IG - Adaptor gem  $\alpha_s$  - Standard maximum angulation  $\alpha_c$  - Standard maximum angulation  $\alpha_{di}$  - Direct to implant maximum angulation

## SCREWS

DYNAMIC SCREW	LENGTH	SCREWDRIVER
	18	43.618.201.01-2
41.318.083.01-2	24	43.624.201.01-2
	32	43.632.201.01-2



STRAIGHT SCREW	TYPE	SCREWDRIVER
40.318.007.01-2	TORX T6	43.601.107.01-2



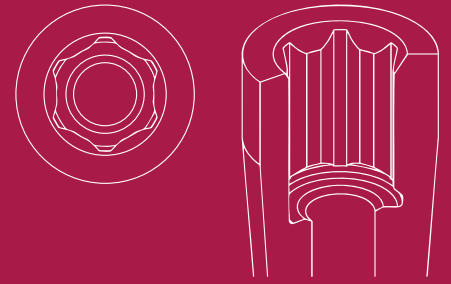

# COMPATIBLE WITH O111

## LIST OF COMPATIBILITIES AVAILABLE

BRENT MEDICAL

### STANDARD DYNAMIC TIBASE

GH (mm)	$\alpha_s$	$\alpha_c$	NON ENGAGING	ENGAGING
0,4	45°	30°	31.323.111.01-2	31.313.111.01-2
2,5	25°	-	-	31.313.111.03-2



### DYNAMIC SCANBODY (LAB/CLIN)

H (mm)	SCANBODY	ADAPTOR	SCREWDRIVER ADAPTOR
10	52.410.117.01-2		43.621.410.01-2
12	52.412.117.01-2	50.310.110.04-2 (IG=3mm)	43.624.410.01-2



#### LAB SCANBODY

30.413.002.01-2



### DYNAMIC MILLING TOOL

SHANK	$\alpha_{di}$	DYNAMIC MILLING TOOL	DIGITAL ANALOG
3		33.360.756.01-2	34.610.110.01-2
4	20°	33.460.756.01-2	
6		33.660.756.01-2	

### ANALOG



LIBRARY OPTIONS: GH = Gingival Height CH = Cement Height H = Height IG = Adaptor 3mm  $\alpha_s$  = Standard maximum angulation  $\alpha_c$  = Standard maximum angulation  $\alpha_{di}$  = Direct to implant maximum angulation

## SCREWS

DYNAMIC SCREW	LENGTH	SCREWDRIVER
	18	43.618.201.01-2
41.318.083.01-2	24	43.624.201.01-2
	32	43.632.201.01-2



STRAIGHT SCREW	TYPE	SCREWDRIVER
40.320.003.06-2	TORX T6	43.601.107.01-2



## MULTI-UNIT

### STRAIGHT MULTI-UNIT

GH (mm)	NON ENGAGING
1	42.303.111.01-2
2	42.303.111.02-2
3	42.303.111.03-2
4	42.303.111.04-2



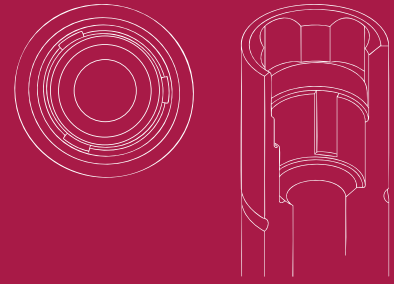

# COMPATIBLE WITH O119

## LIST OF COMPATIBILITIES AVAILABLE

BIOHORIZONS - CAMLOG

### STANDARD DYNAMIC TIBASE

GH (mm)	$\alpha_s$	$\alpha_c$	NON ENGAGING	ENGAGING
1	35°	-	31.321.119.01-2	31.311.119.01-2
2	30°	-	31.321.119.02-2	31.311.119.02-2



### DYNAMIC SCANBODY (LAB/CLIN)

H (mm)	SCANBODY	ADAPTOR	SCREWDRIVER ADAPTOR
10	52.410.132.01-2		43.621.410.01-2
12	52.412.132.01-2	50.311.119.03-2 (IG=3mm)	43.624.410.01-2



#### LAB SCANBODY

30.410.006.01-2



### DYNAMIC MILLING TOOL

SHANK	$\alpha_{di}$	DYNAMIC MILLING TOOL	DIGITAL ANALOG
3		33.360.756.01-2	34.611.119.01-2
4	25°	33.460.756.01-2	
6		33.660.756.01-2	



LIBRARY OPTIONS: GH = Gingival Height CH = Cement Height H = Height IG = Adaptor 3mm  $\alpha_s$  = Standard maximum angulation  $\alpha_c$  = Standard maximum angulation  $\alpha_{di}$  = Direct to implant maximum angulation

## SCANBODY OP

SCANBODY	PEEK PINS	HEIGHT	TYPE	SCREWDRIVER
54.315.119.21-2	49.414.000.01-2	6	A	43.625.105.01-2
	49.415.000.01-2	9	A	
	49.416.000.01-2	13	A	
	49.414.000.02-2	6	B	
	49.415.000.02-2	9	B	
	49.416.000.02-2	13	B	
	49.414.000.03-2	6	C	
	49.415.000.03-2	9	C	
	49.416.000.03-2	13	C	
	49.416.000.04-2	13	D	
49.416.000.05-2	13	E		



## SCREWS

DYNAMIC SCREW	LENGTH	SCREWDRIVER
41.316.080.01-2	18	43.618.201.01-2
	24	43.624.201.01-2
	32	43.632.201.01-2



STRAIGHT SCREW	TYPE	SCREWDRIVER
40.316.005.07-2	Hex. 1.27	43.625.105.01-2



LIBRARY OPTIONS: GH = Gingival Height CH = Cement Height H = Height IG = Adaptor 3mm αs = Standard maximum angulation αc = Standard maximum angulation αd = Direct to implant maximum angulation

## MULTI-UNIT

### STRAIGHT MULTI-UNIT

GH (mm)	NON ENGAGING
1	42.301.119.01-2
2	42.301.119.02-2
3	42.301.119.03-2
4	42.301.119.04-2



### ANGULATED MULTI-UNIT 20°

GH (mm)	ENGAGING
3.5/3.9	48.312.119.03-2



# COMPATIBLE WITH O120

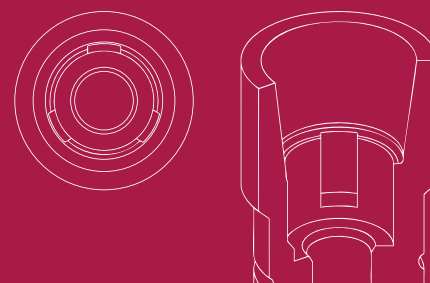

## LIST OF COMPATIBILITIES AVAILABLE

BIOHORIZONS - CAMLOG

### STANDARD DYNAMIC TIBASE

GH (mm)	$\alpha_s$	$\alpha_c$	NON ENGAGING	ENGAGING
1	45°	25°	31.323.121.01-2	31.313.121.01-2



### DYNAMIC 3TIBASE

GH (mm)	$\alpha_s$ CH=5mm	$\alpha_s$ CH=7mm	$\alpha_s$ CH=9mm	NON ENGAGING	ENGAGING
2	25°	20°	15°	-	31.313.121.22-2
3	25°	20°	10°	-	31.313.121.23-2



### DYNAMIC SCANBODY (LAB/CLIN)

H (mm)	SCANBODY	ADAPTOR	SCREWDRIVER ADAPTOR
10	52.410.108.01-2		43.621.410.01-2
12	52.412.108.01-2	50.312.120.03-2 (IG=3mm)	43.624.410.01-2



#### LAB SCANBODY

30.413.002.01-2



LIBRARY OPTIONS: GH = Gingival Height CH = Cement Height H = Height IG = Adaptor 3mm  $\alpha_s$  = Standard maximum angulation  $\alpha_c$  = Standard maximum angulation  $\alpha_d$  = Direct to implant maximum angulation

## DYNAMIC MILLING TOOL

## ANALOG

SHANK	$\alpha_{di}$	DYNAMIC MILLING TOOL	DIGITAL ANALOG
3		33.360.754.01-2	34.612.120.01-2
4	20°	33.460.754.01-2	
6		33.660.754.01-2	



## SCREWS

DYNAMIC SCREW	LENGTH	SCREWDRIVER
	18	43.618.201.01-2
41.316.080.01-2	24	43.624.201.01-2
	32	43.632.201.01-2



STRAIGHT SCREW	TYPE	SCREWDRIVER
40.316.005.07-2	Hex. 1.27	43.625.105.01-2



## MULTI-UNIT

### STRAIGHT MULTI-UNIT

GH (mm)	NON ENGAGING
1	42.303.121.01-2
2	42.303.121.02-2
3	42.303.121.03-2
4	42.303.121.04-2



**ANGULATED MULTI-UNIT 20°**

GH (mm)	ENGAGING
2.5/3.9	48.312.120.02-2
3.5/4.9	48.312.120.03-2



**INTERNAL MULTI-UNIT**

GH (mm)	ENGAGING
2	62.303.121.02-2
4	62.303.121.04-2



# COMPATIBLE WITH O121

LIST OF COMPATIBILITIES **AVAILABLE**  
CAMLOG

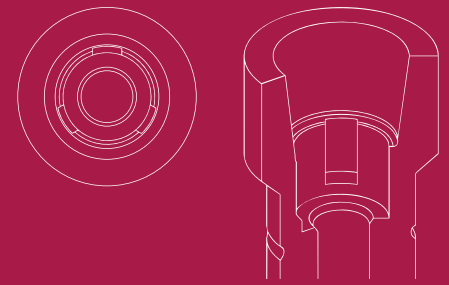

## STANDARD DYNAMIC TIBASE

GH (mm)	$\alpha_s$	$\alpha_c$	NON ENGAGING	ENGAGING
1	45°	25°	31.323.121.01-2	31.313.121.01-2



## DYNAMIC 3TIBASE

GH (mm)	$\alpha_s$ CH=5mm	$\alpha_s$ CH=7mm	$\alpha_s$ CH=9mm	NON ENGAGING	ENGAGING
2	25°	20°	15°	-	31.313.121.22-2
3	25°	20°	10°	-	31.313.121.23-2



## DYNAMIC SCANBODY (LAB/CLIN)

H (mm)	SCANBODY	ADAPTOR	SCREWDRIVER ADAPTOR
10	52.410.109.01-2	50.313.121.01-2	43.621.410.01-2
12	52.412.109.01-2	50.313.121.03-2 (IG=3mm)	43.624.410.01-2



### LAB SCANBODY

30.413.002.01-2



LIBRARY OPTIONS: GH = Gingival Height CH = Cement Height H = Height IG = Adaptor 3mm  $\alpha_s$  = Standard maximum angulation  $\alpha_c$  = Standard maximum angulation  $\alpha_d$  = Direct to implant maximum angulation

## DYNAMIC MILLING TOOL

## ANALOG

SHANK	$\alpha_{di}$	DYNAMIC MILLING TOOL	DIGITAL ANALOG
3		33.360.754.01-2	34.613.121.01-2
4	20°	33.460.754.01-2	
6		33.660.754.01-2	



## SCANBODY OP

SCANBODY	PEEK PINS	HEIGHT	TYPE	SCREWDRIVER
54.315.121.21-2	49.414.000.01-2	6	A	43.625.105.01-2
	49.415.000.01-2	9	A	
	49.416.000.01-2	13	A	
	49.414.000.02-2	6	B	
	49.415.000.02-2	9	B	
	49.416.000.02-2	13	B	
	49.414.000.03-2	6	C	
	49.415.000.03-2	9	C	
	49.416.000.03-2	13	C	
	49.416.000.04-2	13	D	
49.416.000.05-2	13	E		



## SCREWS

DYNAMIC SCREW	LENGTH	SCREWDRIVER
41.316.080.01-2	18	43.618.201.01-2
	24	43.624.201.01-2
	32	43.632.201.01-2



STRAIGHT SCREW	TYPE	SCREWDRIVER
40.316.005.07-2	Hex. 1.27	43.625.105.01-2



LIBRARY OPTIONS: GH = Gingival Height CH = Cement Height H = Height IG = Adaptor 3mm  $\alpha_s$  = Standard maximum angulation  $\alpha_d$  = Standard maximum angulation  $\alpha_{di}$  = Direct to implant maximum angulation

## MULTI-UNIT

### STRAIGHT MULTI-UNIT

GH (mm)	NON ENGAGING
1	42.303.121.01-2
2	42.303.121.02-2
3	42.303.121.03-2
4	42.303.121.04-2



### INTERNAL MULTI-UNIT

GH (mm)	ENGAGING
2	62.303.121.02-2
4	62.303.121.04-2



# COMPATIBLE WITH O124

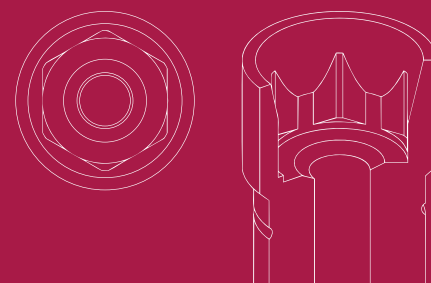

## LIST OF COMPATIBILITIES **AVAILABLE**

HAHN IMPLANT (GLIDEWELL) - NOBEL BIOCARE

### STANDARD DYNAMIC TIBASE

GH (mm)	$\alpha_s$	$\alpha_c$	NON ENGAGING	ENGAGING
1,4	42°	19°	31.324.124.01-2	31.314.124.01-2



### DYNAMIC SCANBODY (LAB/CLIN)

H (mm)	SCANBODY	ADAPTOR	SCREWDRIVER ADAPTOR
10	52.410.125.01-2	50.314.124.01-2	43.621.410.01-2 43.624.410.01-2



#### LAB SCANBODY

30.414.003.01-2



### DYNAMIC MILLING TOOL

SHANK	$\alpha_{di}$	DYNAMIC MILLING TOOL	DIGITAL ANALOG
3		33.335.758.01-2	34.614.124.01-2
4	30°	33.435.758.01-2	
6		33.635.758.01-2	

### ANALOG



LIBRARY OPTIONS: GH = Gingival Height CH = Cement Height H = Height IG = Adaptor 3mm  $\alpha_s$  = Standard maximum angulation  $\alpha_c$  = Standard maximum angulation  $\alpha_{di}$  = Direct to implant maximum angulation

**SCANBODY OP**

SCANBODY	PEEK PINS	HEIGHT	TYPE	SCREWDRIVER
54.315.124.21-2	49.414.000.01-2	6	A	43.625.108.01-2
	49.415.000.01-2	9	A	
	49.416.000.01-2	13	A	
	49.414.000.02-2	6	B	
	49.415.000.02-2	9	B	
	49.416.000.02-2	13	B	
	49.414.000.03-2	6	C	
	49.415.000.03-2	9	C	
	49.416.000.03-2	13	C	
	49.416.000.04-2	13	D	
49.416.000.05-2	13	E		



**SCREWS**

DYNAMIC SCREW	LENGTH	SCREWDRIVER
41.320.075.01-2	18	43.618.201.01-2
	24	43.624.201.01-2
	32	43.632.201.01-2



STRAIGHT SCREW	TYPE	SCREWDRIVER
40.320.008.02-2	UNIGRIP	43.625.108.01-2



LIBRARY OPTIONS: GH = Gingival Height CH = Cement Height H = Height IG = Adaptor 3mm αs = Standard maximum angulation αc = Standard maximum angulation αd = Direct to implant maximum angulation

# COMPATIBLE WITH O125

LIST OF COMPATIBILITIES **AVAILABLE**  
MEDENTIS

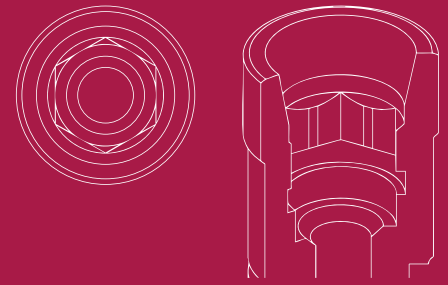

## STANDARD DYNAMIC TIBASE

GH (mm)	$\alpha_S$	$\alpha_C$	NON ENGAGING	ENGAGING
1,1	42°	20°	31.323.125.01-2	31.313.125.01-2
2	25°	15°	31.323.125.02-2	31.313.125.02-2



## DYNAMIC 3TIBASE

GH (mm)	$\alpha_S$ CH=5mm	$\alpha_S$ CH=7mm	$\alpha_S$ CH=9mm	NON ENGAGING	ENGAGING
1,1	30°	25°	15°	31.323.125.21-2	31.313.125.21-2
3	20°	15°	10°	-	31.313.125.23-2



## DYNAMIC SCANBODY (LAB/CLIN)

H (mm)	SCANBODY	ADAPTOR	SCREWDRIVER ADAPTOR
10	52.410.117.01-2	50.313.125.01-2	43.621.410.01-2
12	52.412.117.01-2		43.624.410.01-2



### LAB SCANBODY

30.413.002.01-2



LIBRARY OPTIONS: GH = Gingival Height CH = Cement Height H = Height IG = Adaptor 3mm  $\alpha_S$  = Standard maximum angulation  $\alpha_C$  = Standard maximum angulation  $\alpha_D$  = Direct to implant maximum angulation

## DYNAMIC MILLING TOOL

## ANALOG

SHANK	$\alpha_{di}$	DYNAMIC MILLING TOOL	DIGITAL ANALOG
3		33.315.804.01-2	34.613.125.01-2
4	25°	33.415.804.01-2	
6		33.615.804.01-2	



## SCANBODY OP

SCANBODY	PEEK PINS	HEIGHT	TYPE	SCREWDRIVER
54.315.125.21-2	49.414.000.01-2	6	A	43.601.103.02-2
	49.415.000.01-2	9	A	
	49.416.000.01-2	13	A	
	49.414.000.02-2	6	B	
	49.415.000.02-2	9	B	
	49.416.000.02-2	13	B	
	49.414.000.03-2	6	C	
	49.415.000.03-2	9	C	
	49.416.000.03-2	13	C	
	49.416.000.04-2	13	D	
49.416.000.05-2	13	E		



## SCREWS

DYNAMIC SCREW	HIGH	LENGTH	SCREWDRIVER
41.316.078.01-2	41.316.124.01-2	18	43.618.201.01-2
		24	43.624.201.01-2
		32	43.632.201.01-2



STRAIGHT SCREW	TYPE	SCREWDRIVER
40.316.007.01-2	TORX T6	43.601.107.01-2



LIBRARY OPTIONS: GH = Gingival Height CH = Cement Height H = Height IG = Adaptor 3mm  $\alpha_s$  = Standard maximum angulation  $\alpha_c$  = Standard maximum angulation  $\alpha_d$  = Direct to implant maximum angulation

## MULTI-UNIT

### STRAIGHT MULTI-UNIT

GH (mm)	NON ENGAGING
1	42.303.125.01-2
2	42.303.125.02-2
3	42.303.125.03-2
4	42.303.125.04-2



### ANGULATED MULTI-UNIT 20°

GH (mm)	ENGAGING
1,5/2,9	48.312.125.01-2
2,5/3,9	48.312.125.02-2
3,5/4,9	48.312.125.03-2



# COMPATIBLE WITH O128

## LIST OF COMPATIBILITIES AVAILABLE

MEGAGEN

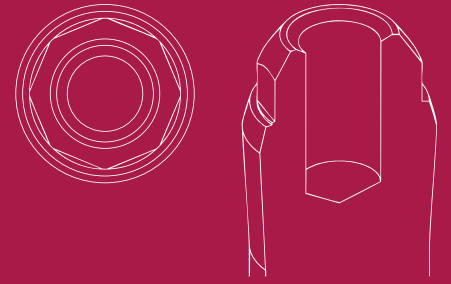

### STANDARD DYNAMIC TIBASE

GH (mm)	$\alpha_S$	$\alpha_C$	NON ENGAGING	ENGAGING
2,5	45°	30°	31.322.128.01-2	-
<b>LAB SCANBODY</b>				
30.413.002.01-2				



### SCREWS

DYNAMIC SCREW	LENGTH	SCREWDRIVER
41.320.044.01-2	18	43.618.201.01-2
	24	43.624.201.01-2
	32	43.632.201.01-2



STRAIGHT SCREW	TYPE	SCREWDRIVER
40.320.003.05-2	Hex. 1.20	43.601.103.01-2



LIBRARY OPTIONS: GH = Gingival Height CH = Cement Height H = Height IG = Adaptor 3mm  $\alpha_S$  = Standard maximum angulation  $\alpha_C$  = Standard maximum angulation  $\alpha_D$  = Direct to implant maximum angulation

# COMPATIBLE WITH O129

LIST OF COMPATIBILITIES **AVAILABLE**  
NOBEL BIOCARE - SOUTHERN IMPLANTS

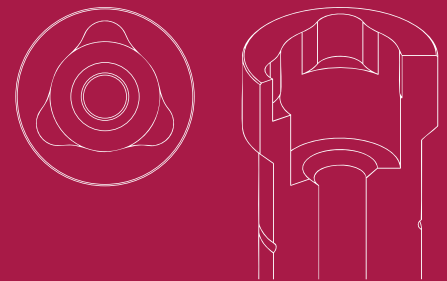

## STANDARD DYNAMIC TIBASE

GH (mm)	$\alpha_s$	$\alpha_c$	NON ENGAGING	ENGAGING
0,3	35°	30°	31.325.129.01-2	31.315.129.01-2



## DYNAMIC SCANBODY (LAB/CLIN)

H (mm)	SCANBODY	ADAPTOR	SCREWDRIVER ADAPTOR
10	52.410.130.01-2	50.315.129.01-2	43.621.410.01-2 43.624.410.01-2



### LAB SCANBODY

30.415.007.01-2



## DYNAMIC MILLING TOOL

SHANK	$\alpha_{di}$	DYNAMIC MILLING TOOL	DIGITAL ANALOG	ANALOG
3		33.390.958.01-2	34.615.129.01-2	22.615.129.01-2
4	30°	33.490.958.01-2		
6		33.690.958.01-2		



LIBRARY OPTIONS: GH = Gingival Height CH = Cement Height H = Height IG = Adaptor 3mm  $\alpha_s$  = Standard maximum angulation  $\alpha_c$  = Standard maximum angulation  $\alpha_{di}$  = Direct to implant maximum angulation

## SCREWS

DYNAMIC SCREW	LENGTH	SCREWDRIVER
	18	43.618.201.01-2
41.320.090.01-2	24	43.624.201.01-2
	32	43.632.201.01-2



STRAIGHT SCREW	TYPE	SCREWDRIVER
40.320.008.03-2	UNIGRIP	43.625.108.01-2



# COMPATIBLE WITH O130

## LIST OF COMPATIBILITIES AVAILABLE

DENTAURUM

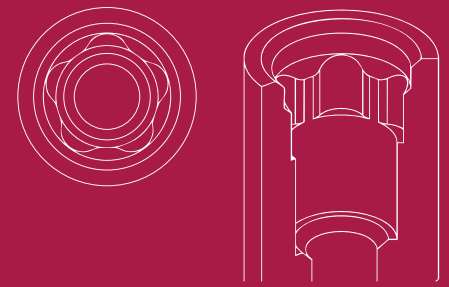

### STANDARD DYNAMIC TIBASE

GH (mm)	$\alpha_S$	$\alpha_C$	NON ENGAGING	ENGAGING
0,5	30°	29°	31.322.130.01-2	31.312.130.01-2
<b>LAB SCANBODY</b>				
30.412.001.01-2				



### SCREWS

DYNAMIC SCREW	LENGTH	SCREWDRIVER
41.316.081.01-2	18	43.618.201.01-2
	24	43.624.201.01-2
	32	43.632.201.01-2



STRAIGHT SCREW	TYPE	SCREWDRIVER
40.316.005.08-2	Hex. 1.27	43.625.105.01-2



LIBRARY OPTIONS: GH = Gingival Height CH = Cement Height H = Height IG = Adaptor 3mm  $\alpha_S$  = Standard maximum angulation  $\alpha_C$  = Standard maximum angulation  $\alpha_D$  = Direct to implant maximum angulation

# COMPATIBLE WITH O131

LIST OF COMPATIBILITIES **AVAILABLE**  
DENTAURUM

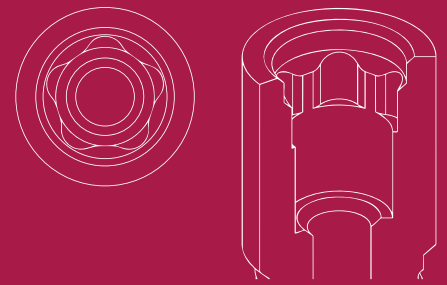

## STANDARD DYNAMIC TIBASE

GH (mm)	$\alpha_s$	$\alpha_c$	NON ENGAGING	ENGAGING
0,5	45°	29°	31.323.131.01-2	31.313.131.01-2



## DYNAMIC 3TIBASE

GH (mm)	$\alpha_s$ CH=5mm	$\alpha_s$ CH=7mm	$\alpha_s$ CH=9mm	NON ENGAGING	ENGAGING
0,5	30°	20°	15°	31.323.131.21-2	31.313.131.21-2



## LAB SCANBODY

30.413.002.01-2



## SCREWS

DYNAMIC SCREW	LENGTH	SCREWDRIVER
	18	43.618.201.01-2
41.316.081.01-2	24	43.624.201.01-2
	32	43.632.201.01-2



STRAIGHT SCREW	TYPE	SCREWDRIVER
40.316.005.08-2	Hex. 1.27	43.625.105.01-2



LIBRARY OPTIONS: GH = Gingival Height CH = Cement Height H = Height IG = Adaptor 3mm  $\alpha_s$  = Standard maximum angulation  $\alpha_c$  = Standard maximum angulation  $\alpha_d$  = Direct to implant maximum angulation

# COMPATIBLE WITH O132

## LIST OF COMPATIBILITIES AVAILABLE

DENTAURUM

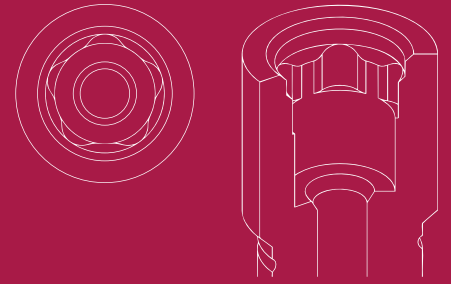

### STANDARD DYNAMIC TIBASE

GH (mm)	$\alpha_s$	$\alpha_c$	NON ENGAGING	ENGAGING
0,5	45°	28°	31.324.132.01-2	31.314.132.01-2
<b>LAB SCANBODY</b>				
30.414.003.01-2				



### SCREWS

DYNAMIC SCREW	LENGTH	SCREWDRIVER
41.316.081.01-2	18	43.618.201.01-2
	24	43.624.201.01-2
	32	43.632.201.01-2



STRAIGHT SCREW	TYPE	SCREWDRIVER
40.316.005.08-2	Hex. 1.27	43.625.105.01-2



LIBRARY OPTIONS: GH = Gingival Height CH = Cement Height H = Height IG = Adaptor 3mm  $\alpha_s$  = Standard maximum angulation  $\alpha_c$  = Standard maximum angulation  $\alpha_d$  = Direct to implant maximum angulation

# COMPATIBLE WITH O135

LIST OF COMPATIBILITIES **AVAILABLE**  
STRAUMANN

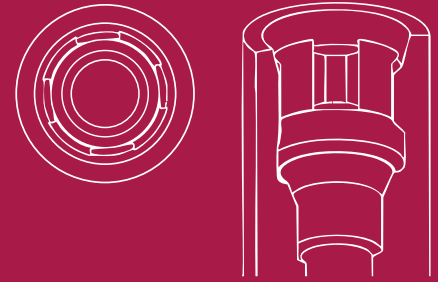

## STANDARD DYNAMIC TIBASE

GH (mm)	$\alpha_s$	$\alpha_c$	NON ENGAGING	ENGAGING
1	45°	30°	31.320.135.01-2	31.310.135.01-2



### LAB SCANBODY

30.410.006.01-2



## DYNAMIC MILLING TOOL

SHANK	$\alpha_{di}$	DYNAMIC MILLING TOOL
3		33.315.804.01-2
4	25°	33.415.804.01-2
6		33.615.804.01-2



## SCANBODY OP

SCANBODY	PEEK PINS	HEIGHT	TYPE	SCREWDRIVER
54.315.135.21-2	49.414.000.01-2	6	A	43.601.107.01-2
	49.415.000.01-2	9	A	
	49.416.000.01-2	13	A	
	49.414.000.02-2	6	B	
	49.415.000.02-2	9	B	
	49.416.000.02-2	13	B	
	49.414.000.03-2	6	C	
	49.415.000.03-2	9	C	
	49.416.000.03-2	13	C	
	49.416.000.04-2	13	D	
49.416.000.05-2	13	E		



## SCREWS

DYNAMIC SCREW	LENGTH	SCREWDRIVER
41.314.080.01-2	18	43.618.201.01-2
	24	43.624.201.01-2
	32	43.632.201.01-2



STRAIGHT SCREW	TYPE	SCREWDRIVER
40.314.007.02-2	TORX T6	43.601.107.01-2



# COMPATIBLE WITH O136

## LIST OF COMPATIBILITIES AVAILABLE

ALPHABIO

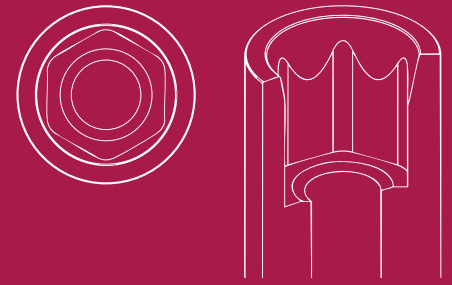

### STANDARD DYNAMIC TIBASE

GH (mm)	$\alpha_s$	$\alpha_c$	NON ENGAGING	ENGAGING
0,7	45°	30°	31.320.136.01-2	31.310.136.01-2
1,5	25°	20°	31.320.136.02-2	31.310.136.02-2
3	20°	-	31.320.136.04-2	31.310.136.04-2
4	20°	-	31.320.136.05-2	31.310.136.05-2
5	15°	-	31.320.136.06-2	31.310.136.06-2



### DYNAMIC SCANBODY (LAB/CLIN)

H (mm)	SCANBODY	ADAPTOR	SCREWDRIVER ADAPTOR
10	52.410.128.01-2	50.310.136.01-2 50.310.136.04-2 (IG=3mm)	43.621.415.01-2



#### LAB SCANBODY

30.410.006.01-2



### DYNAMIC MILLING TOOL

SHANK	$\alpha_{di}$	DYNAMIC MILLING TOOL	DIGITAL ANALOG
3		33.360.754.01-2	34.610.136.01-2
4	25°	33.460.754.01-2	
6		33.660.754.01-2	

### ANALOG



LIBRARY OPTIONS: GH = Gingival Height CH = Cement Height H = Height IG = Adaptor 3mm  $\alpha_s$  = Standard maximum angulation  $\alpha_c$  = Standard maximum angulation  $\alpha_{di}$  = Direct to implant maximum angulation

## SCREWS

DYNAMIC SCREW	LENGTH	SCREWDRIVER
	18	43.618.201.01-2
41.316.071.01-2	24	43.624.201.01-2
	32	43.632.201.01-2



STRAIGHT SCREW	TYPE	SCREWDRIVER
40.316.004.03-2	Hex. 1.25	43.601.104.01-2



## MULTI-UNIT

### STRAIGHT MULTI-UNIT

GH (mm)	NON ENGAGING
1	42.300.136.01-2
2	42.300.136.02-2
3	42.300.136.03-2
4	42.300.136.04-2



# COMPATIBLE WITH O137

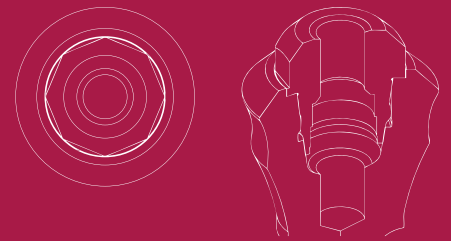

## LIST OF COMPATIBILITIES AVAILABLE

STRAUMANN

### STANDARD DYNAMIC TIBASE

GH (mm)	$\alpha_S$	$\alpha_C$	NON ENGAGING	ENGAGING
0,6	45°	30°	31.324.137.01-2	31.314.137.01-2
<b>LAB SCANBODY</b>				
30.414.008.01-2				



### SCREWS

DYNAMIC SCREW	LENGTH	SCREWDRIVER
41.320.044.01-2	18	43.618.201.01-2
	24	43.624.201.01-2
	32	43.632.201.01-2



STRAIGHT SCREW	TYPE	SCREWDRIVER
40.320.007.04-2	TORX T6	43.601.107.01-2



LIBRARY OPTIONS: GH = Gingival Height CH = Cement Height H = Height IG = Adaptor 3mm  $\alpha_S$  = Standard maximum angulation  $\alpha_C$  = Standard maximum angulation  $\alpha_D$  = Direct to implant maximum angulation

# COMPATIBLE WITH O145

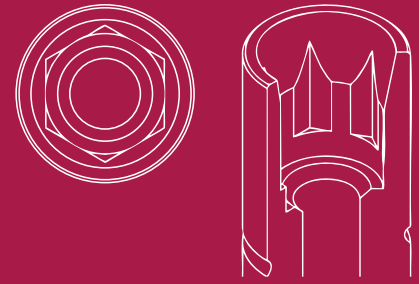

## LIST OF COMPATIBILITIES AVAILABLE

ADIN

### STANDARD DYNAMIC TIBASE

GH (mm)	$\alpha_s$	$\alpha_c$	NON ENGAGING	ENGAGING
1,5	45°	-	31.320.145.01-2	31.310.145.01-2



### DYNAMIC SCANBODY (LAB/CLIN)

H (mm)	SCANBODY
10	52.410.128.01-2



LAB SCANBODY
30.410.006.01-2



### SCREWS

DYNAMIC SCREW	LENGTH	SCREWDRIVER
41.315.078.01-2	18	43.618.201.01-2
	24	43.624.201.01-2
	32	43.632.201.01-2



STRAIGHT SCREW	TYPE	SCREWDRIVER
40.314.005.01-2	Hex. 1.27	43.601.105.01-2



LIBRARY OPTIONS: GH = Gingival Height CH = Cement Height H = Height IG = Adaptor 3mm  $\alpha_s$  = Standard maximum angulation  $\alpha_c$  = Standard maximum angulation  $\alpha_d$  = Direct to implant maximum angulation

# COMPATIBLE WITH O149

## LIST OF COMPATIBILITIES AVAILABLE

ANTHOGYR

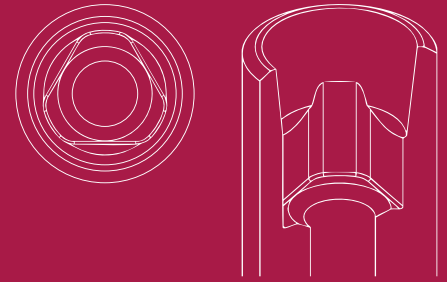

### STANDARD DYNAMIC TIBASE

GH (mm)	$\alpha_s$	$\alpha_c$	NON ENGAGING	ENGAGING
1,5	45°	29°	31.323.149.01-2	31.313.149.01-2



### DYNAMIC SCANBODY (LAB/CLIN)

H (mm)	SCANBODY	ADAPTOR	SCREWDRIVER ADAPTOR
10	52.410.132.01-2	50.310.161.01-2	43.621.415.01-2
12	52.412.132.01-2		



LAB SCANBODY
30.413.002.01-2



### DYNAMIC MILLING TOOL

SHANK	$\alpha_{di}$	DYNAMIC MILLING TOOL
3		33.320.704-01-2*
4	25°	33.420.704.01-2*
6		33.620.704.01-2*

### ANALOG

DIGITAL ANALOG
34.610.161.01-2



\*Only for R

LIBRARY OPTIONS: GH = Gingival Height CH = Cement Height H = Height IG = Adaptor 3mm  $\alpha_s$  = Standard maximum angulation  $\alpha_c$  = Standard maximum angulation  $\alpha_{di}$  = Direct to implant maximum angulation

## SCREWS

DYNAMIC SCREW	LENGTH	SCREWDRIVER
	18	43.618.201.01-2
41.316.079.01-2	24	43.624.201.01-2
	32	43.632.201.01-2



## STRAIGHT SCREW

40.316.014.01-2



## MULTI-UNIT

### STRAIGHT MULTI-UNIT

GH (mm)	NON ENGAGING
1	42.302.161.01-2
2	42.302.161.02-2
3	42.302.161.03-2



### ANGULATED MULTI-UNIT 20°

GH (mm)	NON ENGAGING
3/4.4	48.312.161.05-2



# COMPATIBLE WITH O150

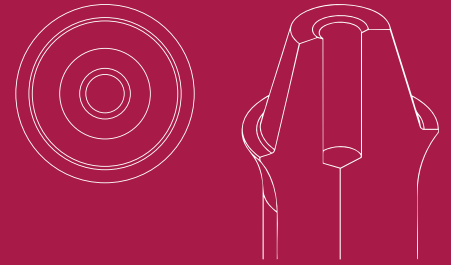

## LIST OF COMPATIBILITIES AVAILABLE

BEGO

### STANDARD DYNAMIC TIBASE

GH (mm)	$\alpha_S$	$\alpha_C$	NON ENGAGING	ENGAGING
0,5	45°	-	31.323.150.01-2	-

**LAB  
SCANBODY**

30.413.005.01-2



### SCREWS

DYNAMIC SCREW	LENGTH	SCREWDRIVER
	18	43.618.201.01-2
41.314.046.01-2	24	43.624.201.01-2
	32	43.632.201.01-2



LIBRARY OPTIONS: GH = Gingival Height CH = Cement Height H = Height IG = Adaptor 3mm  $\alpha_S$  = Standard maximum angulation  $\alpha_C$  = Standard maximum angulation  $\alpha_D$  = Direct to implant maximum angulation

# COMPATIBLE WITH O151

LIST OF COMPATIBILITIES **AVAILABLE**  
BTI

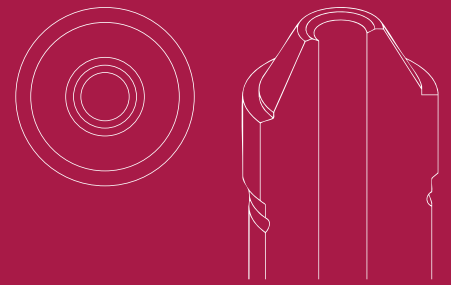

## STANDARD DYNAMIC TIBASE

GH (mm)	$\alpha_s$	$\alpha_c$	NON ENGAGING	ENGAGING
0,3	45°	30°	31.320.145.01-2	31.310.145.01-2



## DYNAMIC SCANBODY (LAB/CLIN)

H (mm)	SCANBODY	ADAPTOR	SCREWDRIVER ADAPTOR
9	52.409.123.01-2	50.313.151.01-2	43.621.410.01-2 43.624.410.01-2



## DYNAMIC MILLING TOOL

SHANK	$\alpha_{di}$	DYNAMIC MILLING TOOL
3		33.390.716.01-2
4	30°	33.490.716.01-2
6		33.690.716.01-2

## ANALOG

DIGITAL ANALOG
34.613.151.01-2



## SCREWS

DYNAMIC SCREW	LENGTH	SCREWDRIVER
	18	43.618.201.01-2
41.314.039.01-2	24	43.624.201.01-2
	32	43.632.201.01-2



LIBRARY OPTIONS: GH = Gingival Height CH = Cement Height H = Height IG = Adaptor 3mm  $\alpha_s$  = Standard maximum angulation  $\alpha_c$  = Standard maximum angulation  $\alpha_{di}$  = Direct to implant maximum angulation

STRAIGHT SCREW	TYPE	SCREWDRIVER
40.314.008.01-2	UNIGRIP	43.625.108.01-2



# COMPATIBLE WITH O158

LIST OF COMPATIBILITIES **AVAILABLE**  
IMPLANT DIRECT

## SCANBODY REFERENCE

SCANBODY	PEEK PINS	HEIGHT	TYPE	SCREWDRIVER	
54.322.158.31-2	49.414.000.01-2	6	A	43.625.105.01-2	
	49.415.000.01-2	9	A		
	49.416.000.01-2	13	A		
	49.414.000.02-2	6	B		
	49.415.000.02-2	9	B		
	49.416.000.02-2	13	B		
	49.414.000.03-2	6	C		
	49.415.000.03-2	9	C		
	49.416.000.03-2	13	C		
	49.416.000.04-2	13	D		
	49.416.000.05-2	13	E		
		CAPS	HEIGHT		TYPE
		49.418.000.01-2	3,8		Regular
		49.418.000.02-2	3,8		Wide
		49.419.000.01-2	6		Regular
	49.419.000.02-2	6	Wide		
	49.420.000.01-2	8	Regular		
	49.420.000.02-2	8	Wide		



## SCREWS

DYNAMIC SCREW	LENGTH	SCREWDRIVER
41.317.040.01-2	18	43.618.201.01-2
	24	43.624.201.01-2
	32	43.632.201.01-2



LIBRARY OPTIONS: GH = Gingival Height CH = Cement Height H = Height IG = Adaptor 3mm Gs = Standard maximum angulation Gc = Standard maximum angulation Gd = Direct to implant maximum angulation

# COMPATIBLE WITH O159

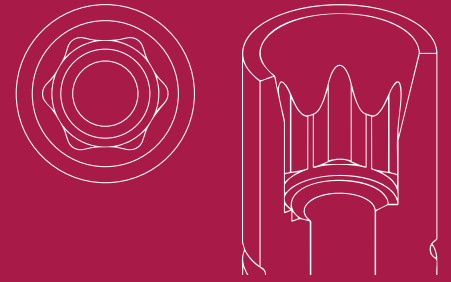

## LIST OF COMPATIBILITIES **AVAILABLE**

HAHN IMPLANT (GLIDEWELL) - NOBEL BIOCARE - REFLECT

### STANDARD DYNAMIC TIBASE

GH (mm)	$\alpha_s$	$\alpha_c$	NON ENGAGING	ENGAGING
1,5	41°	17°	31.320.159.01-2	31.310.159.01-2



### DYNAMIC SCANBODY (LAB/CLIN)

H (mm)	SCANBODY	ADAPTOR	SCREWDRIVER ADAPTOR
10	52.410.128.01-2	50.310.159.01-2	43.621.415.01-2



#### LAB SCANBODY

30.410.006.01-2



### DYNAMIC MILLING TOOL

SHANK	$\alpha_{di}$	DYNAMIC MILLING TOOL	DIGITAL ANALOG	ANALOG
3		33.335.754.01-2*	34.610.159.01-2	22.610.159.01-2
4	25°	33.435.754.01-2*		
6		33.635.754.01-2*		

\*Only for R



LIBRARY OPTIONS: GH = Gingival Height CH = Cement Height H = Height IG = Adaptor 3mm  $\alpha_s$  = Standard maximum angulation  $\alpha_c$  = Standard maximum angulation  $\alpha_{di}$  = Direct to implant maximum angulation

## SCREWS

DYNAMIC SCREW	LENGTH	SCREWDRIVER
	18	43.618.201.01-2
41.314.067.02-2	24	43.624.201.01-2
	32	43.632.201.01-2



STRAIGHT SCREW	TYPE	SCREWDRIVER
40.314.008.02-2	UNIGRIP	43.625.108.01-2



## MULTI-UNIT

### STRAIGHT MULTI-UNIT

GH (mm)	NON ENGAGING
1	42.300.159.01-2
2	42.300.159.02-2
3	42.300.159.03-2
4	42.300.159.04-2



# COMPATIBLE WITH O160

LIST OF COMPATIBILITIES **AVAILABLE**

STRAUMANN

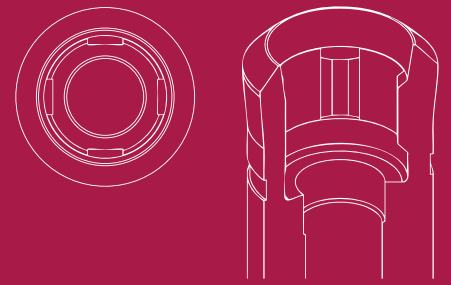

## STANDARD DYNAMIC TIBASE

GH (mm)	$\alpha_s$	$\alpha_c$	NON ENGAGING	ENGAGING
0,5	45°	30°	31.320.160.01-2	31.310.160.01-2



## DYNAMIC SCANBODY (LAB/CLIN)

H (mm)	SCANBODY	ADAPTOR	SCREWDRIVER ADAPTOR
10	52.410.131.01-2	50.310.160.01-2	43.621.415.01-2



LAB SCANBODY	SCANALOG
30.410.006.01-2	23.410.160.01-2



## DYNAMIC MILLING TOOL

SHANK	$\alpha_{di}$	DYNAMIC MILLING TOOL	DIGITAL ANALOG	ANALOG
3		33.315.804.01-2	34.610.160.01-2	22.610.160.01
4	25°	33.415.804.01-2		
6		33.615.804.01-2		



LIBRARY OPTIONS: GH = Gingival Height CH = Cement Height H = Height IG = Adaptor 3mm  $\alpha_s$  = Standard maximum angulation  $\alpha_c$  = Standard maximum angulation  $\alpha_{di}$  = Direct to implant maximum angulation

## SCREWS

DYNAMIC SCREW	LENGTH	SCREWDRIVER
	18	43.618.201.01-2
41.316.078.01-2	24	43.624.201.01-2
	32	43.632.201.01-2



STRAIGHT SCREW	TYPE	SCREWDRIVER
40.316.007.01-2	TORX T6	43.601.107.01-2



# COMPATIBLE WITH O161

## LIST OF COMPATIBILITIES AVAILABLE

ANTHOGYR



### STANDARD DYNAMIC TIBASE

GH (mm)	$\alpha_s$	$\alpha_c$	NON ENGAGING	ENGAGING
1,5	45°	25°	31.320.161.01-2	31.310.161.01-2



### DYNAMIC SCANBODY (LAB/CLIN)

H (mm)	SCANBODY	ADAPTOR	SCREWDRIVER ADAPTOR
10	52.410.132.01-2		
12	52.412.132.01-2	50.310.161.01-2	43.621.410.01-2



#### LAB SCANBODY

30.410.006.01-2



### DYNAMIC MILLING TOOL

SHANK	$\alpha_{di}$	DYNAMIC MILLING TOOL	DIGITAL ANALOG
3		33.320.704.01-2*	34.610.161.01-2
4	25°	33.420.704.01-2*	
6		33.620.704.01-2*	

\*Only for R



LIBRARY OPTIONS: GH = Gingival Height CH = Cement Height H = Height IG = Adaptor 3mm  $\alpha_s$  = Standard maximum angulation  $\alpha_c$  = Standard maximum angulation  $\alpha_{di}$  = Direct to implant maximum angulation

## SCREWS

DYNAMIC SCREW	LENGTH	SCREWDRIVER
	18	43.618.201.01-2
41.316.079.01-2	24	43.624.201.01-2
	32	43.632.201.01-2



### STRAIGHT SCREW

40.316.014.01-2



## MULTI-UNIT

### STRAIGHT MULTI-UNIT

GH (mm)	NON ENGAGING
1	42.302.161.01-2
2	42.302.161.02-2
3	42.302.161.03-2



### ANGULATED MULTI-UNIT 20°

GH (mm)	NON ENGAGING
3/4.4	48.312.161.05-2



# COMPATIBLE WITH O162

LIST OF COMPATIBILITIES **AVAILABLE**  
ANTHOGYR

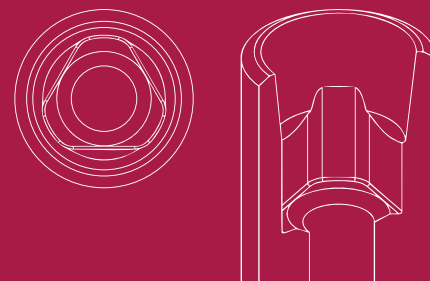

## STANDARD DYNAMIC TIBASE

GH (mm)	$\alpha_s$	$\alpha_c$	NON ENGAGING	ENGAGING
1,5	45°	24°	31.324.162.01-2	31.314.162.01-2



## DYNAMIC SCANBODY (LAB/CLIN)

H (mm)	SCANBODY	ADAPTOR	SCREWDRIVER ADAPTOR
10	52.410.132.01-2		
12	52.412.132.01-2	50.310.161.01-2	43.621.415.01-2



### LAB SCANBODY

30.414.003.01-2



## DYNAMIC MILLING TOOL

SHANK	$\alpha_{di}$	DYNAMIC MILLING TOOL
3		33.320.704.01-2*
4	25°	33.420.704.01-2*
6		33.620.704.01-2*

\*Only for R

## ANALOG

DIGITAL ANALOG
34.610.161.01-2



LIBRARY OPTIONS: GH = Gingival Height CH = Cement Height H = Height IG = Adaptor 3mm  $\alpha_s$  = Standard maximum angulation  $\alpha_c$  = Standard maximum angulation  $\alpha_{di}$  = Direct to implant maximum angulation

## SCREWS

DYNAMIC SCREW	LENGTH	SCREWDRIVER
	18	43.618.201.01-2
41.316.079.01-2	24	43.624.201.01-2
	32	43.632.201.01-2



## STRAIGHT SCREW

40.316.014.01-2



# COMPATIBLE WITH O163

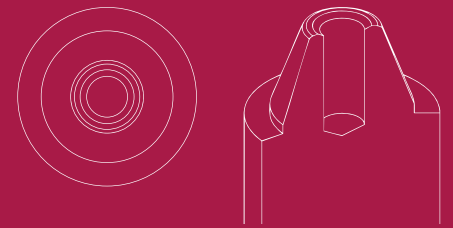

## LIST OF COMPATIBILITIES AVAILABLE

ANTHOGYR

### STANDARD DYNAMIC TIBASE

GH (mm)	$\alpha_s$	$\alpha_c$	NON ENGAGING	ENGAGING
0,5	45°	30°	31.323.163.01-2	-



### DYNAMIC SCANBODY (LAB/CLIN)

H (mm)	SCANBODY	ADAPTOR	SCREWDRIVER ADAPTOR
8	52.408.112.01-2	50.313.163.01-2	43.620.411.01-2



#### LAB SCANBODY

30.413.005.01-2



### DYNAMIC MILLING TOOL

SHANK	$\alpha_{di}$	DYNAMIC MILLING TOOL	DIGITAL ANALOG
3		33.390.716.01-2	34.613.163.01-2
4	30°	33.490.716.01-2	
6		33.690.716.01-2	

### ANALOG



LIBRARY OPTIONS: GH = Gingival Height CH = Cement Height H = Height IG = Adaptor 3mm  $\alpha_s$  = Standard maximum angulation  $\alpha_c$  = Standard maximum angulation  $\alpha_{di}$  = Direct to implant maximum angulation

**SCREWS**

DYNAMIC SCREW	LENGTH	SCREWDRIVER
	18	43.618.201.01-2
41.314.039.01-2	24	43.624.201.01-2
	32	43.632.201.01-2



**STRAIGHT SCREW**

40.314.014.01-2



# COMPATIBLE WITH O166

## LIST OF COMPATIBILITIES AVAILABLE

KUWOTECH - LASAK

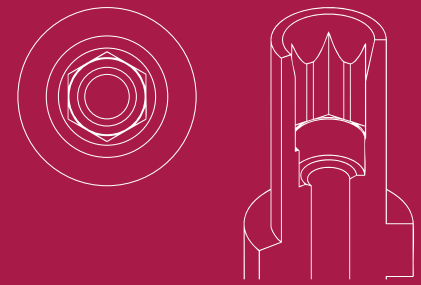

### STANDARD DYNAMIC TIBASE

GH (mm)	$\alpha_s$	$\alpha_c$	NON ENGAGING	ENGAGING
0,9	45°	30°	31.320.166.01-2	31.310.166.01-2



### DYNAMIC SCANBODY (LAB/CLIN)

H (mm)	SCANBODY	ADAPTOR	SCREWDRIVER ADAPTOR
10	52.410.128.01-2	50.310.166.03-2 (IG=3mm)	43.621.415.01-2



#### LAB SCANBODY

30.410.006.01-2



### DYNAMIC MILLING TOOL

SHANK	$\alpha_{di}$	DYNAMIC MILLING TOOL	DIGITAL ANALOG
3		33.335.754.01-2	34.610.166.01-2
4	25°	33.435.754.01-2	
6		33.635.754.01-2	



### ANALOG

LIBRARY OPTIONS: GH = Gingival Height CH = Cement Height H = Height IG = Adaptor 3mm  $\alpha_s$  = Standard maximum angulation  $\alpha_c$  = Standard maximum angulation  $\alpha_{di}$  = Direct to implant maximum angulation

**SCREWS**

DYNAMIC SCREW	LENGTH	SCREWDRIVER
	18	43.618.201.01-2
41.314.084.01-2	24	43.624.201.01-2
	32	43.632.201.01-2



# COMPATIBLE WITH O167

LIST OF COMPATIBILITIES **AVAILABLE**  
KUWOTECH - LASAK

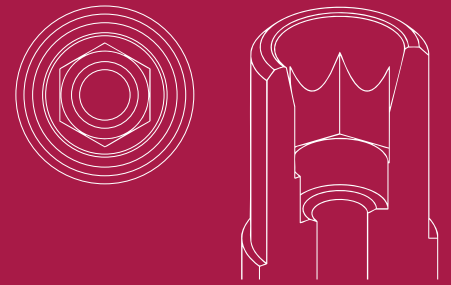

## STANDARD DYNAMIC TIBASE

GH (mm)	$\alpha_s$	$\alpha_c$	NON ENGAGING	ENGAGING
0,9	43°	30°	31.322.167.01-2	31.312.167.01-2



## DYNAMIC SCANBODY (LAB/CLIN)

H (mm)	SCANBODY	ADAPTOR	SCREWDRIVER ADAPTOR
10	52.410.117.01-2	50.313.167.03-2 (IG=3mm)	43.621.410.01-2
12	52.412.117.01-2		43.624.410.01-2



### LAB SCANBODY

30.412.001.01-2



## DYNAMIC MILLING TOOL

SHANK	$\alpha_{di}$	DYNAMIC MILLING TOOL	DIGITAL ANALOG
3		33.330.734.01-2	34.613.167.01-2
4	20°	33.430.734.01-2	
6		33.630.734.01-2	

## ANALOG



LIBRARY OPTIONS: GH = Gingival Height CH = Cement Height H = Height IG = Adaptor 3mm  $\alpha_s$  = Standard maximum angulation  $\alpha_c$  = Standard maximum angulation  $\alpha_{di}$  = Direct to implant maximum angulation

**SCREWS**

DYNAMIC SCREW	LENTH	SCREWDRIVER
	18	43.618.201.01-2
41.316.084.02-2	24	43.624.201.01-2
	32	43.632.201.01-2



STRAIGHT SCREW	TYPE	SCREWDRIVER
40.316.004.01-2	Hex. 1.25	43.601.104.01-2



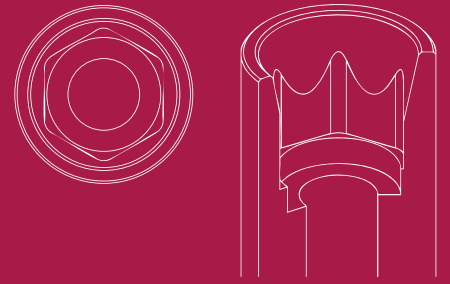

# COMPATIBLE WITH O169

## LIST OF COMPATIBILITIES AVAILABLE

ALPHABIO

### STANDARD DYNAMIC TIBASE

GH (mm)	$\alpha_S$	$\alpha_C$	NON ENGAGING	ENGAGING
0,6	45°	29°	31.322.169.01-2	31.312.169.01-2
1,5	25°	15°	31.322.169.02-2	31.312.169.02-2
3	20°	-	31.322.169.04-2	31.312.169.04-2



### DYNAMIC 3TIBASE

GH (mm)	$\alpha_S$ CH=5mm	$\alpha_S$ CH=7mm	$\alpha_S$ CH=9mm	NON ENGAGING	ENGAGING
1,5	30°	25°	15°	31.322.169.22-2	31.312.169.22-2
3	25°	20°	15°	31.322.169.24-2	31.312.169.24-2



### DYNAMIC SCANBODY (LAB/CLIN)

H (mm)	SCANBODY	ADAPTOR	SCREWDRIVER ADAPTOR
10	52.410.117.01-2	50.312.169.01-2	43.621.410.01-2
12	52.412.117.01-2	50.312.169.04-2 (IG=3mm)	43.624.410.01-2



#### LAB SCANBODY

30.412.001.01-2



LIBRARY OPTIONS: GH = Gingival Height CH = Cement Height H = Height IG = Adaptor 3mm  $\alpha_S$  = Standard maximum angulation  $\alpha_C$  = Standard maximum angulation  $\alpha_D$  = Direct to implant maximum angulation

## DYNAMIC MILLING TOOL

## ANALOG

SHANK	$\alpha_{di}$	DYNAMIC MILLING TOOL	DIGITAL ANALOG
3		33.330.734.01-2	34.612.169.01-2
4	25°	33.430.734.01-2	
6		33.630.734.01-2	



## SCANBODY OP

SCANBODY	PEEK PINS	HEIGHT	TYPE	SCREWDRIVER
54.315.169.21-2	49.414.000.01-2	6	A	43.601.104.01-2
	49.415.000.01-2	9	A	
	49.416.000.01-2	13	A	
	49.414.000.02-2	6	B	
	49.415.000.02-2	9	B	
	49.416.000.02-2	13	B	
	49.414.000.03-2	6	C	
	49.415.000.03-2	9	C	
	49.416.000.03-2	13	C	
	49.416.000.04-2	13	D	
49.416.000.05-2	13	E		



## SCREWS

DYNAMIC SCREW	LENGTH	SCREWDRIVER
41.317.070.01-2	18	43.618.201.01-2
	24	43.624.201.01-2
	32	43.632.201.01-2



## MULTI-UNIT

### STRAIGHT MULTI-UNIT

GH (mm)	NON ENGAGING
1	42.302.169.01-2
2	42.302.169.02-2
3	42.302.169.03-2
4	42.302.169.04-2



### ANGULATED MULTI-UNIT 20°

GH (mm)	ENGAGING
1,5/2,9	48.312.169.01-2
2,5/3,9	48.312.169.02-2
3,5/4,9	48.312.169.03-2



### INTERNAL MULTI-UNIT

GH (mm)	ENGAGING
3	62.302.169.03-2
4	62.302.169.04-2



# COMPATIBLE WITH O170

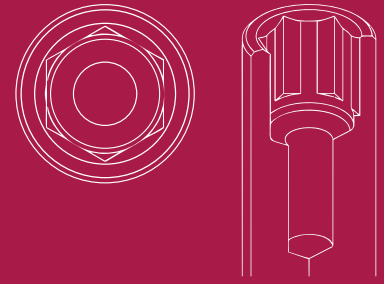

## LIST OF COMPATIBILITIES AVAILABLE

SIC INVENT

### STANDARD DYNAMIC TIBASE

GH (mm)	$\alpha_s$	$\alpha_c$	NON ENGAGING	ENGAGING
0,3	38°	-	31.322.170.01-2	31.312.170.01-2



### DYNAMIC 3TIBASE

GH (mm)	$\alpha_s$ CH=5mm	$\alpha_s$ CH=7mm	$\alpha_s$ CH=9mm	NON ENGAGING	ENGAGING
0,3	30°	20°	15°	31.322.170.21-2	31.312.170.21-2



### DYNAMIC SCANBODY (LAB/CLIN)

H (mm)	SCANBODY
10	52.410.104.01-2
12	52.412.104.01-2



LAB SCANBODY
30.410.006.01-2



LIBRARY OPTIONS: GH = Gingival Height CH = Cement Height H = Height IG = Adaptor 3mm  $\alpha_s$  = Standard maximum angulation  $\alpha_c$  = Standard maximum angulation  $\alpha_d$  = Direct to implant maximum angulation

## DYNAMIC MILLING TOOL

SHANK	$\alpha_{di}$	DYNAMIC MILLING TOOL
3		33.390.716.01-2
4	25°	33.490.716.01-2
6		33.690.716.01-2



## SCANBODY OP

SCANBODY	PEEK PINS	HEIGHT	TYPE	SCREWDRIVER
54.315.170.21-2	49.414.000.01-2	6	A	43.601.103.02-2
	49.415.000.01-2	9	A	
	49.416.000.01-2	13	A	
	49.414.000.02-2	6	B	
	49.415.000.02-2	9	B	
	49.416.000.02-2	13	B	
	49.414.000.03-2	6	C	
	49.415.000.03-2	9	C	
	49.416.000.03-2	13	C	
	49.416.000.04-2	13	D	
49.416.000.05-2	13	E		



## SCREWS

DYNAMIC SCREW	LENGTH	SCREWDRIVER
41.316.079.02-2	18	43.618.201.01-2
	24	43.624.201.01-2
	32	43.632.201.01-2



# COMPATIBLE WITH O171

LIST OF COMPATIBILITIES **AVAILABLE**  
SIC INVENT

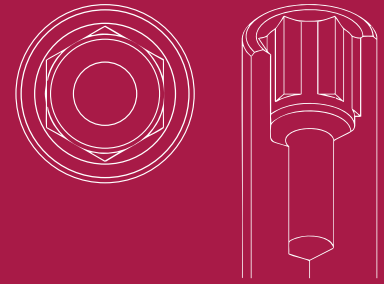

## STANDARD DYNAMIC TIBASE

GH (mm)	$\alpha_s$	$\alpha_c$	NON ENGAGING	ENGAGING
0,3	35°	-	31.323.171.01-2	31.313.171.01-2



## DYNAMIC SCANBODY (LAB/CLIN)

H (mm)	SCANBODY
10	52.410.117.01-2
12	52.412.117.01-2



LAB SCANBODY
30.412.001.01-2



## DYNAMIC MILLING TOOL

SHANK	$\alpha_{di}$	DYNAMIC MILLING TOOL
3		33.390.716.01-2
4	25°	33.490.716.01-2
6		33.690.716.01-2



LIBRARY OPTIONS: GH = Gingival Height CH = Cement Height H = Height IG = Adaptor 3mm  $\alpha_s$  = Standard maximum angulation  $\alpha_c$  = Standard maximum angulation  $\alpha_{di}$  = Direct to implant maximum angulation

## SCANBODY OP

SCANBODY	PEEK PINS	HEIGHT	TYPE	SCREWDRIVER
54.315.170.21-2	49.414.000.01-2	6	A	43.601.103.02-2
	49.415.000.01-2	9	A	
	49.416.000.01-2	13	A	
	49.414.000.02-2	6	B	
	49.415.000.02-2	9	B	
	49.416.000.02-2	13	B	
	49.414.000.03-2	6	C	
	49.415.000.03-2	9	C	
	49.416.000.03-2	13	C	
	49.416.000.04-2	13	D	
49.416.000.05-2	13	E		



## SCREWS

DYNAMIC SCREW	LENGTH	SCREWDRIVER
41.316.079.02-2	18	43.618.201.01-2
	24	43.624.201.01-2
	32	43.632.201.01-2



# COMPATIBLE WITH O173

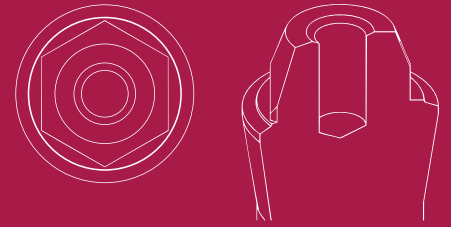

## LIST OF COMPATIBILITIES AVAILABLE

KLOCKNER

### STANDARD DYNAMIC TIBASE

GH (mm)	$\alpha_s$	$\alpha_c$	NON ENGAGING	ENGAGING
0,5	45°	30°	31.323.173.01-2	-
<b>LAB SCANBODY</b>				
30.413.005.01-2				



### SCREWS

DYNAMIC SCREW	LENGTH	SCREWDRIVER
	18	43.618.201.01-2
41.314.040.02-2	24	43.624.201.01-2
	32	43.632.201.01-2



### STRAIGHT SCREW

40.314.012.01-2



LIBRARY OPTIONS: GH = Gingival Height CH = Cement Height H = Height IG = Adaptor 3mm  $\alpha_s$  = Standard maximum angulation  $\alpha_c$  = Standard maximum angulation  $\alpha_d$  = Direct to implant maximum angulation

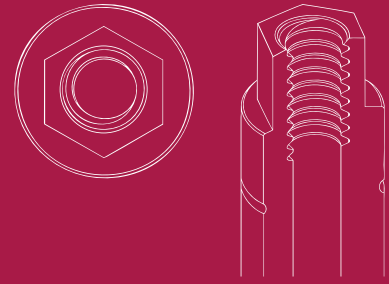

# COMPATIBLE WITH O176

## LIST OF COMPATIBILITIES AVAILABLE

EASY IMPLANT

### STANDARD DYNAMIC TIBASE

GH (mm)	$\alpha_s$	$\alpha_c$	NON ENGAGING	ENGAGING
0,5	35°	-	-	31.310.176.01-2



### DYNAMIC SCANBODY (LAB/CLIN)

H (mm)	SCANBODY	ADAPTOR	SCREWDRIVER ADAPTOR
8	52.408.138.01-2	50.310.176.01-2	43.621.415.01-2



#### LAB SCANBODY

30.410.006.01-2



### DYNAMIC MILLING TOOL

### ANALOG

SHANK	$\alpha_{di}$	DYNAMIC MILLING TOOL	DIGITAL ANALOG
3		33.360.756.01-2	34.610.176.01-2
4	35°	33.460.756.01-2	
6		33.660.756.01-2	



### SCREWS

DYNAMIC SCREW	LENGTH	SCREWDRIVER
	18	43.618.201.01-2
41.314.044.01-2	24	43.624.201.01-2
	32	43.632.201.01-2



LIBRARY OPTIONS: GH = Gingival Height CH = Cement Height H = Height IG = Adaptor 3mm  $\alpha_s$  = Standard maximum angulation  $\alpha_c$  = Standard maximum angulation  $\alpha_{di}$  = Direct to implant maximum angulation

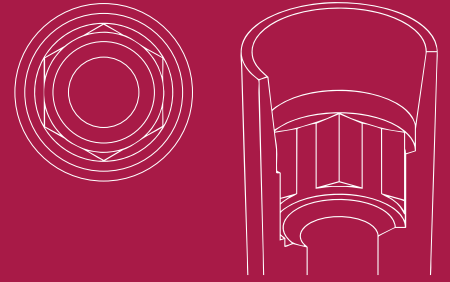

# COMPATIBLE WITH O178

## LIST OF COMPATIBILITIES AVAILABLE

P-I BRANEMARK - ZIACOM - ZIMMER

### STANDARD DYNAMIC TIBASE

GH (mm)	$\alpha_s$	$\alpha_c$	NON ENGAGING	ENGAGING
1,5	45°	-	31.320.178.01-2	31.310.178.01-2
<b>LAB SCANBODY</b>				
30.410.006.01-2				



### ANALOG

DIGITAL ANALOG
34.610.178.01-2



### SCREWS

DYNAMIC SCREW	LENGTH	SCREWDRIVER
	18	43.618.201.01-2
41.316.080.01-2	24	43.624.201.01-2
	32	43.632.201.01-2



### MULTI-UNIT

#### INTERNAL MULTI-UNIT

GH (mm)	NON ENGAGING
4	62.300.178.04-2



LIBRARY OPTIONS: GH = Gingival Height CH = Cement Height H = Height IG = Adaptor 3mm  $\alpha_s$  = Standard maximum angulation  $\alpha_c$  = Standard maximum angulation  $\alpha_d$  = Direct to implant maximum angulation

# COMPATIBLE WITH O181

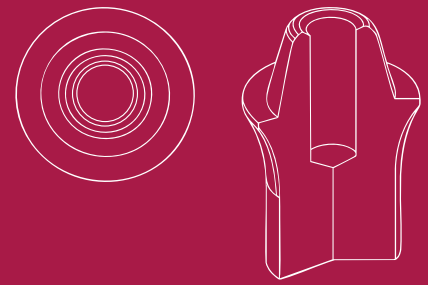

## LIST OF COMPATIBILITIES AVAILABLE

PALTOP - SURCAM DENTAL

### STANDARD DYNAMIC TIBASE

GH (mm)	$\alpha_s$	$\alpha_c$	NON ENGAGING	ENGAGING
0,4	45°	-	31.322.181.01-2	-



### DYNAMIC 3TIBASE

GH (mm)	$\alpha_s$ CH=5mm	$\alpha_s$ CH=7mm	$\alpha_s$ CH=9mm	NON ENGAGING	ENGAGING
0,4	30°	30°	20°	31.322.181.21-2	-



### DYNAMIC SCANBODY (LAB/CLIN)

H (mm)	SCANBODY	ADAPTOR	SCREWDRIVER ADAPTOR
8	52.408.112.01-2	50.312.181.01-2	43.620.411.01-2



LAB SCANBODY	SCANALOG
30.413.005.01-2	23.412.181.01-2



### DYNAMIC MILLING TOOL

SHANK	$\alpha_{di}$	DYNAMIC MILLING TOOL	DIGITAL ANALOG
3		33.360.756.01-2	34.612.181.01-2
4	30°	33.460.756.01-2	
6		33.660.756.01-2	



LIBRARY OPTIONS: GH = Gingival Height CH = Cement Height H = Height IG = Adaptor 3mm  $\alpha_s$  = Standard maximum angulation  $\alpha_c$  = Standard maximum angulation  $\alpha_{di}$  = Direct to implant maximum angulation

### SCANBODY REFERENCE

SCANBODY	PEEK PINS	HEIGHT	TYPE	SCREWDRIVER
54.322.181.31-2	49.414.000.01-2	6	A	43.601.103.02-2
	49.415.000.01-2	9	A	
	49.416.000.01-2	13	A	
	49.414.000.02-2	6	B	
	49.415.000.02-2	9	B	
	49.416.000.02-2	13	B	
	49.414.000.03-2	6	C	
	49.415.000.03-2	9	C	
	49.416.000.03-2	13	C	
	49.416.000.04-2	13	D	
	49.416.000.05-2	13	E	
	CAPS	HEIGHT	TYPE	
	49.418.000.01-2	3,8	Regular	
	49.418.000.02-2	3,8	Wide	
	49.419.000.01-2	6	Regular	
49.419.000.02-2	6	Wide		
49.420.000.01-2	8	Regular		
49.420.000.02-2	8	Wide		



### SCREWS

DYNAMIC SCREW	LENGTH	SCREWDRIVER
41.318.043.01-2	18	43.618.201.01-2
	24	43.624.201.01-2
	32	43.632.201.01-2



LIBRARY OPTIONS: GH = Gingival Height CH = Cement Height H = Height IG = Adaptor 3mm αs = Standard maximum angulation αc = Standard maximum angulation αd = Direct to implant maximum angulation

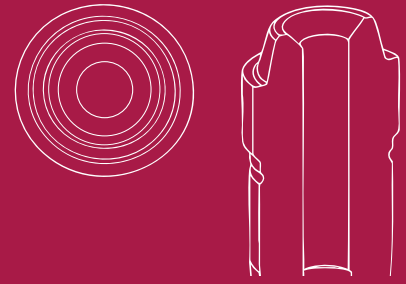

# COMPATIBLE WITH O183

LIST OF COMPATIBILITIES **AVAILABLE**  
ANKLYOS

## STANDARD DYNAMIC TIBASE

GH (mm)	$\alpha_s$	$\alpha_c$	NON ENGAGING	ENGAGING
0,5	45°	-	31.322.183.01-2	-



## DYNAMIC SCANBODY (LAB/CLIN)

H (mm)	SCANBODY	ADAPTOR	SCREWDRIVER ADAPTOR
8	52.408.136.01-2	50.312.183.01-2	43.620.411.01-2



## DYNAMIC MILLING TOOL

SHANK	$\alpha_{di}$	DYNAMIC MILLING TOOL
3		33.330.734.01-2
4	30°	33.430.734.01-2
6		33.630.734.01-2

## ANALOG

DIGITAL ANALOG
34.612.183.01-2



LIBRARY OPTIONS: GH = Gingival Height CH = Cement Height H = Height IG = Adaptor 3mm  $\alpha_s$  = Standard maximum angulation  $\alpha_c$  = Standard maximum angulation  $\alpha_{di}$  = Direct to implant maximum angulation

## SCANBODY REFERENCE

SCANBODY	PEEK PINS	HEIGHT	TYPE
54.322.183.31-2	49.414.000.01-2	6	A
	49.415.000.01-2	9	A
	49.416.000.01-2	13	A
	49.414.000.02-2	6	B
	49.415.000.02-2	9	B
	49.416.000.02-2	13	B
	49.414.000.03-2	6	C
	49.415.000.03-2	9	C
	49.416.000.03-2	13	C
	49.416.000.04-2	13	D
	49.416.000.05-2	13	E
	CAPS	HEIGHT	TYPE
	49.418.000.01-2	3,8	Regular
	49.418.000.02-2	3,8	Wide
	49.419.000.01-2	6	Regular
49.419.000.02-2	6	Wide	
49.420.000.01-2	8	Regular	
49.420.000.02-2	8	Wide	



## SCREWS

DYNAMIC SCREW	LENGTH	SCREWDRIVER
41.316.048.02-2	18	43.618.201.01-2
	24	43.624.201.01-2
	32	43.632.201.01-2



# COMPATIBLE WITH O186

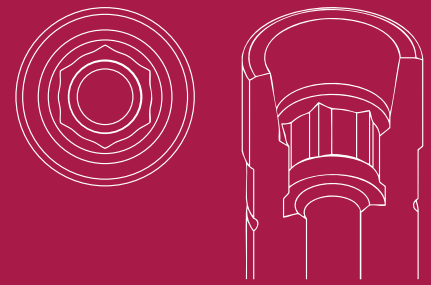

## LIST OF COMPATIBILITIES AVAILABLE

NEODENT

### STANDARD DYNAMIC TIBASE

GH (mm)	$\alpha_s$	$\alpha_c$	NON ENGAGING	ENGAGING
1,2	40°	30°	31.323.186.01-2	31.313.186.01-2
2,5	20°	18°	31.323.186.02-2	31.313.186.02-2
3,5	15°	-	31.323.186.03-2	31.313.186.03-2



### DYNAMIC 3TIBASE

GH (mm)	$\alpha_s$ CH=5mm	$\alpha_s$ CH=7mm	$\alpha_s$ CH=9mm	NON ENGAGING	ENGAGING
1,2	30°	25°	15°	31.323.186.21-2	31.313.186.21-2
2,5	30°	25°	15°	31.323.186.22-2	31.313.186.22-2



### DYNAMIC SCANBODY (LAB/CLIN)

H (mm)	SCANBODY	ADAPTOR	SCREWDRIVER ADAPTOR
8	52.408.110.01-2		
10	52.410.110.01-2	50.313.186.04-2 (IG=3mm)	43.621.410.01-2 43.624.410.01-2
12	52.412.110.01-2		



#### LAB SCANBODY

30.413.002.01-2



LIBRARY OPTIONS: GH = Gingival Height CH = Cement Height H = Height IG = Adaptor 3mm  $\alpha_s$  = Standard maximum angulation  $\alpha_c$  = Standard maximum angulation  $\alpha_d$  = Direct to implant maximum angulation

## DYNAMIC MILLING TOOL

## ANALOG

SHANK	$\alpha_{di}$	DYNAMIC MILLING TOOL	DIGITAL ANALOG
3		33.330.734.01-2	34.613.186.01-2
4	25°	33.430.734.01-2	
6		33.630.734.01-2	



## SCANBODY OP

SCANBODY	PEEK PINS	HEIGHT	TYPE
54.315.186.21-2	49.414.000.01-2	6	A
	49.415.000.01-2	9	A
	49.416.000.01-2	13	A
	49.414.000.02-2	6	B
	49.415.000.02-2	9	B
	49.416.000.02-2	13	B
	49.414.000.03-2	6	C
	49.415.000.03-2	9	C
	49.416.000.03-2	13	C
	49.416.000.04-2	13	D
	49.416.000.05-2	13	E



## SCREWS

DYNAMIC SCREW	LENGTH	SCREWDRIVER
41.316.084.02-2	18	43.618.201.01-2
	24	43.624.201.01-2
	32	43.632.201.01-2



## STRAIGHT SCREW

40.316.008.04-2



## MULTI-UNIT

### STRAIGHT MULTI-UNIT

GH (mm)	NON ENGAGING
1	42.303.186.01-2
2	42.303.186.02-2
3	42.303.186.03-2
4	42.303.186.04-2
5	42.303.186.05-2



### ANGULATED MULTI-UNIT 20°

GH (mm)	ENGAGING
2,5/3,9	48.312.186.02-2
3,5/4,9	48.312.186.03-2



# COMPATIBLE WITH O187

LIST OF COMPATIBILITIES **AVAILABLE**  
BEGO

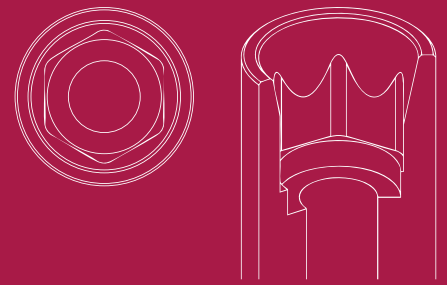

## STANDARD DYNAMIC TIBASE

GH (mm)	$\alpha_s$	$\alpha_c$	NON ENGAGING	ENGAGING
0,3	45°	25°	31.322.009.01-2	31.312.009.01-2
0,5	25°	25°	31.322.009.02-2	31.312.009.02-2
1	25°	-	31.322.009.03-2	31.312.009.03-2



## DYNAMIC SCANBODY (LAB/CLIN)

H (mm)	SCANBODY	ADAPTOR	SCREWDRIVER ADAPTOR
10	52.410.114.01-2	50.312.187.01-2	43.621.410.01-2
12	52.412.114.01-2		43.624.410.01-2



### LAB SCANBODY

30.412.001.01-2



## DYNAMIC MILLING TOOL

SHANK	$\alpha_{di}$	DYNAMIC MILLING TOOL	DIGITAL ANALOG
3		33.390.716.01-2	34.612.187.01-2
4	25°	33.490.716.01-2	
6		33.690.716.01-2	



LIBRARY OPTIONS: GH = Gingival Height CH = Cement Height H = Height IG = Adaptor 3mm  $\alpha_s$  = Standard maximum angulation  $\alpha_c$  = Standard maximum angulation  $\alpha_{di}$  = Direct to implant maximum angulation

**SCREWS**

DYNAMIC SCREW	LENGTH	SCREWDRIVER
	18	43.618.201.01-2
41.316.059.01-2	24	43.624.201.01-2
	32	43.632.201.01-2



# COMPATIBLE WITH O188

## LIST OF COMPATIBILITIES AVAILABLE

ADIN

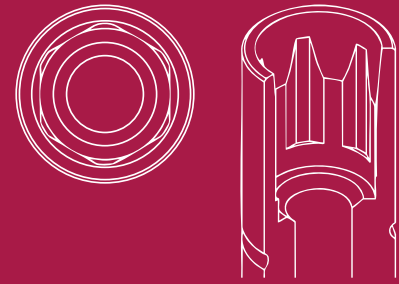

### STANDARD DYNAMIC TIBASE

GH (mm)	$\alpha_s$	$\alpha_c$	NON ENGAGING	ENGAGING
1,5	45°	-	31.320.188.01-2	31.310.188.01-2



### DYNAMIC SCANBODY (LAB/CLIN)

H (mm)	SCANBODY
10	52.410.128.01-2



LAB SCANBODY
30.410.006.01-2



### SCREWS

DYNAMIC SCREW	LENGTH	SCREWDRIVER
	18	43.618.201.01-2
41.315.078.01-2	24	43.624.201.01-2
	32	43.632.201.01-2



LIBRARY OPTIONS: GH = Gingival Height CH = Cement Height H = Height IG = Adaptor 3mm  $\alpha_s$  = Standard maximum angulation  $\alpha_c$  = Standard maximum angulation  $\alpha_d$  = Direct to implant maximum angulation

# COMPATIBLE WITH O190



LIST OF COMPATIBILITIES **AVAILABLE**  
DENTIUM

## STANDARD DYNAMIC TIBASE

GH (mm)	$\alpha_s$	$\alpha_c$	NON ENGAGING	ENGAGING
1,8	45°	-	31.320.190.01-2	31.310.190.01-2



### LAB SCANBODY

30.410.006.01-2



## SCREWS

DYNAMIC SCREW	LENGTH	SCREWDRIVER
	18	43.618.201.01-2
41.316.084.02-2	24	43.624.201.01-2
	32	43.632.201.01-2



LIBRARY OPTIONS: GH = Gingival Height CH = Cement Height H = Height IG = Adaptor 3mm  $\alpha_s$  = Standard maximum angulation  $\alpha_c$  = Standard maximum angulation  $\alpha_d$  = Direct to implant maximum angulation

# COMPATIBLE WITH O191

LIST OF COMPATIBILITIES **AVAILABLE**  
DENTIUM

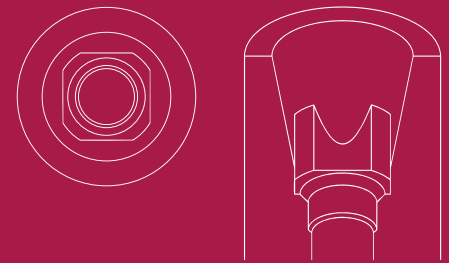

## STANDARD DYNAMIC TIBASE

GH (mm)	$\alpha_s$	$\alpha_c$	NON ENGAGING	ENGAGING
0,8	45°	-	31.322.191.01-2	31.312.191.01-2
<b>LAB SCANBODY</b>				
30.412.001.01-2				



## SCREWS

DYNAMIC SCREW	LENGTH	SCREWDRIVER
41.316.084.02-2	18	43.618.201.01-2
	24	43.624.201.01-2
	32	43.632.201.01-2
STRAIGHT SCREW	TYPE	SCREWDRIVER
40.316.003.01-2	Hex. 1.20	43.601.103.02-2



LIBRARY OPTIONS: GH = Gingival Height CH = Cement Height H = Height IG = Adaptor 3mm  $\alpha_s$  = Standard maximum angulation  $\alpha_c$  = Standard maximum angulation  $\alpha_d$  = Direct to implant maximum angulation

# COMPATIBLE WITH O192

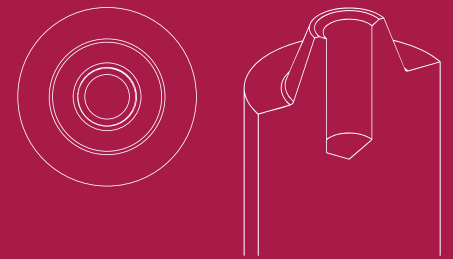

LIST OF COMPATIBILITIES **AVAILABLE**  
DENTIUM

## STANDARD DYNAMIC TIBASE

GH (mm)	$\alpha_s$	$\alpha_c$	NON ENGAGING	ENGAGING
0,3	45°	-	31.323.192.01-2	-



LAB  
SCANBODY

30.413.005.01-2



## SCREWS

DYNAMIC SCREW	LENGTH	SCREWDRIVER
	18	43.618.201.01-2
41.316.048.01-2	24	43.624.201.01-2
	32	43.632.201.01-2



LIBRARY OPTIONS: GH = Gingival Height CH = Cement Height H = Height IG = Adaptor 3mm  $\alpha_s$  = Standard maximum angulation  $\alpha_c$  = Standard maximum angulation  $\alpha_d$  = Direct to implant maximum angulation

# COMPATIBLE WITH O193

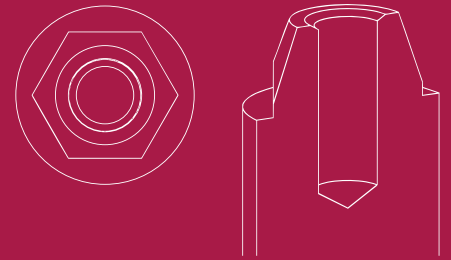

## LIST OF COMPATIBILITIES AVAILABLE

COLLELMEDI - DENTIUM

### STANDARD DYNAMIC TIBASE

GH (mm)	$\alpha_s$	$\alpha_c$	NON ENGAGING	ENGAGING
0,3	45°	-	31.323.193.01-2	-
<b>LAB SCANBODY</b>				
30.413.005.01-2				



### DYNAMIC MILLING TOOL

SHANK	$\alpha_{di}$	DYNAMIC MILLING TOOL
3		33.345.856.01-2
4	0°	33.445.856.01-2
6		33.645.856.01-2

### ANALOG

DIGITAL ANALOG
34.613.193.01-2



LIBRARY OPTIONS: GH = Gingival Height CH = Cement Height H = Height IG = Adaptor 3mm  $\alpha_s$  = Standard maximum angulation  $\alpha_c$  = Standard maximum angulation  $\alpha_{di}$  = Direct to implant maximum angulation

## SCANBODY REFERENCE

SCANBODY	PEEK PINS	HEIGHT	TYPE	SCREWDRIVER
54.322.193.31-2	49.414.000.01-2	6	A	43.625.105.01-2
	49.415.000.01-2	9	A	
	49.416.000.01-2	13	A	
	49.414.000.02-2	6	B	
	49.415.000.02-2	9	B	
	49.416.000.02-2	13	B	
	49.414.000.03-2	6	C	
	49.415.000.03-2	9	C	
	49.416.000.03-2	13	C	
	49.416.000.04-2	13	D	
49.416.000.05-2	13	E		
	CAPS	HEIGHT	TYPE	
	49.418.000.01-2	3,8	Regular	
	49.418.000.02-2	3,8	Wide	
	49.419.000.01-2	6	Regular	
	49.419.000.02-2	6	Wide	
	49.420.000.01-2	8	Regular	
	49.420.000.02-2	8	Wide	



## SCREWS

DYNAMIC SCREW	LENGTH	SCREWDRIVER
41.318.051.02-2	18	43.618.201.01-2
	24	43.624.201.01-2
	32	43.632.201.01-2
STRAIGHT SCREW	TYPE	SCREWDRIVER
40.318.005.01-2	-	43.601.105.01-2



LIBRARY OPTIONS: GH = Gingival Height CH = Cement Height H = Height IG = Adaptor 3mm Gs = Standard maximum angulation Gc = Standard maximum angulation Gd = Direct to implant maximum angulation

# COMPATIBLE WITH O195

## LIST OF COMPATIBILITIES AVAILABLE

ALPHABIO

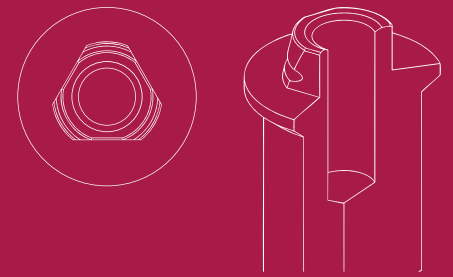

### STANDARD DYNAMIC TIBASE

GH (mm)	$\alpha_S$	$\alpha_C$	NON ENGAGING	ENGAGING
0,5	45°	-	31.323.195.01-2	-



### DYNAMIC 3TIBASE

GH (mm)	$\alpha_S$ CH=5mm	$\alpha_S$ CH=7mm	$\alpha_S$ CH=9mm	NON ENGAGING	ENGAGING
0,5	30°	25°	25°	31.323.195.21-2	-



### LAB SCANBODY

30.413.005.01-2



### DYNAMIC MILLING TOOL

SHANK	$\alpha_{di}$	DYNAMIC MILLING TOOL
3		33.390.716.01-2
4	25°	33.490.716.01-2
6		33.690.716.01-2



LIBRARY OPTIONS: GH = Gingival Height CH = Cement Height H = Height IG = Adaptor 3mm  $\alpha_S$  = Standard maximum angulation  $\alpha_C$  = Standard maximum angulation  $\alpha_{di}$  = Direct to implant maximum angulation

## SCANBODY REFERENCE

SCANBODY	PEEK PINS	HEIGHT	TYPE	SCREWDRIVER
	49.414.000.01-2	6	A	
	49.415.000.01-2	9	A	
	49.416.000.01-2	13	A	
	49.414.000.02-2	6	B	
	49.415.000.02-2	9	B	
	49.416.000.02-2	13	B	
	49.414.000.03-2	6	C	
	49.415.000.03-2	9	C	
	49.416.000.03-2	13	C	
54.322.195.31-2	49.416.000.04-2	13	D	43.601.104.01-2
	49.416.000.05-2	13	E	
	<b>CAPS</b>	<b>HEIGHT</b>	<b>TYPE</b>	
	49.418.000.01-2	3,8	Regular	
	49.418.000.02-2	3,8	Wide	
	49.419.000.01-2	6	Regular	
	49.419.000.02-2	6	Wide	
	49.420.000.01-2	8	Regular	
	49.420.000.02-2	8	Wide	



## SCREWS

DYNAMIC SCREW	HIGH	LENGTH	SCREWDRIVER
		18	43.618.201.01-2
41.317.041.01-2	41.317.052.36-2	24	43.624.201.01-2
		32	43.632.201.01-2



LIBRARY OPTIONS: GH - Gingival Height CH - Cement Height H - Height IG - Adaptor 3mm Gs - Standard maximum angulation Gc - Standard maximum angulation Gd - Direct to implant maximum angulation

# COMPATIBLE WITH O196

## LIST OF COMPATIBILITIES AVAILABLE

GC TECH

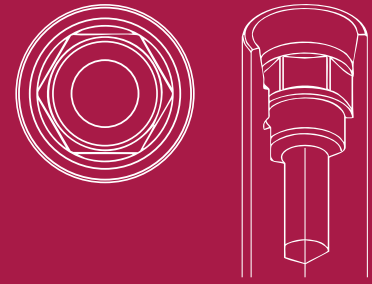

### STANDARD DYNAMIC TIBASE

GH (mm)	$\alpha_s$	$\alpha_c$	NON ENGAGING	ENGAGING
1,2	40°	-	31.320.196.01-2	31.310.196.01-2
2	25°	-	31.320.196.02-2	31.310.196.02-2
3	25°	-	31.320.196.03-2	31.310.196.03-2



#### LAB SCANBODY

30.410.006.01-2



### SCREWS

DYNAMIC SCREW	LENGTH	SCREWDRIVER
	18	43.618.201.01-2
41.316.086.01-2	24	43.624.201.01-2
	32	43.632.201.01-2



LIBRARY OPTIONS: GH = Gingival Height CH = Cement Height H = Height IG = Adaptor 3mm  $\alpha_s$  = Standard maximum angulation  $\alpha_c$  = Standard maximum angulation  $\alpha_d$  = Direct to implant maximum angulation

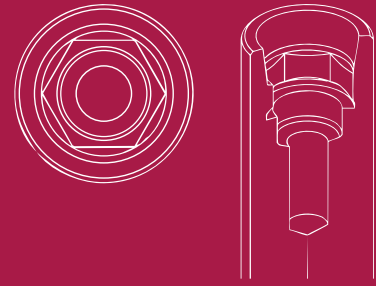

# COMPATIBLE WITH O197

## LIST OF COMPATIBILITIES AVAILABLE

GC TECH

### STANDARD DYNAMIC TIBASE

GH (mm)	$\alpha_s$	$\alpha_c$	NON ENGAGING	ENGAGING
1,2	35°	25°	31.322.197.01-2	31.312.197.01-2
2	20°	25°	31.322.197.02-2	31.312.197.02-2
3	20°	-	31.322.197.03-2	31.312.197.03-2



#### LAB SCANBODY

30.412.001.01-2



### SCREWS

DYNAMIC SCREW	LENGTH	SCREWDRIVER
	18	43.618.201.01-2
41.316.086.01-2	24	43.624.201.01-2
	32	43.632.201.01-2



LIBRARY OPTIONS: GH = Gingival Height CH = Cement Height H = Height IG = Adaptor 3mm  $\alpha_s$  = Standard maximum angulation  $\alpha_c$  = Standard maximum angulation  $\alpha_d$  = Direct to implant maximum angulation

# COMPATIBLE WITH O198

## LIST OF COMPATIBILITIES AVAILABLE

GC TECH

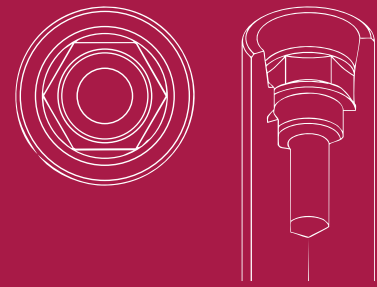

### STANDARD DYNAMIC TIBASE

GH (mm)	$\alpha_S$	$\alpha_C$	NON ENGAGING	ENGAGING
1,2	40°	-	31.324.198.01-2	31.314.198.01-2
<b>LAB SCANBODY</b>				
30.414.003.01-2				



### SCREWS

DYNAMIC SCREW	LENGTH	SCREWDRIVER
41.316.086.01-2	18	43.618.201.01-2
	24	43.624.201.01-2
	32	43.632.201.01-2



LIBRARY OPTIONS: GH = Gingival Height CH = Cement Height H = Height IG = Adaptor 3mm  $\alpha_S$  = Standard maximum angulation  $\alpha_C$  = Standard maximum angulation  $\alpha_D$  = Direct to implant maximum angulation

# COMPATIBLE WITH O205

LIST OF COMPATIBILITIES **AVAILABLE**  
ZIACOM - ZIMMER

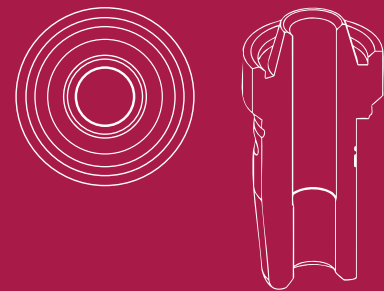

## STANDARD DYNAMIC TIBASE

GH (mm)	$\alpha_s$	$\alpha_c$	NON ENGAGING	ENGAGING
0,3	45°	-	31.322.205.01-2	-



## DYNAMIC SCANBODY (LAB/CLIN)

H (mm)	SCANBODY	ADAPTOR	SCREWDRIVER ADAPTOR
8	52.408.112.01-2	50.312.205.01-2	43.620.411.01-2



### LAB SCANBODY

30.412.001.01-2



## DYNAMIC MILLING TOOL

SHANK	$\alpha_{di}$	DYNAMIC MILLING TOOL	DIGITAL ANALOG
3		33.390.716.01-2	34.612.205.01-2
4	30°	33.490.716.01-2	
6		33.690.716.01-2	

## ANALOG



LIBRARY OPTIONS: GH = Gingival Height CH = Cement Height H = Height IG = Adaptor 3mm  $\alpha_s$  = Standard maximum angulation  $\alpha_c$  = Standard maximum angulation  $\alpha_{di}$  = Direct to implant maximum angulation

**SCANBODY REFERENCE**

SCANBODY	PEEK PINS	HEIGHT	TYPE	SCREWDRIVER
54.322.205.21-2	49.414.000.01-2	6	A	43.625.105.01-2
	49.415.000.01-2	9	A	
	49.416.000.01-2	13	A	
	49.414.000.02-2	6	B	
	49.415.000.02-2	9	B	
	49.416.000.02-2	13	B	
	49.414.000.03-2	6	C	
	49.415.000.03-2	9	C	
	49.416.000.03-2	13	C	
	49.416.000.04-2	13	D	
	49.416.000.05-2	13	E	
		CAPS	HEIGHT	
	49.418.000.01-2	3,8	Regular	
	49.418.000.02-2	3,8	Wide	
	49.419.000.01-2	6	Regular	
	49.419.000.02-2	6	Wide	
	49.420.000.01-2	8	Regular	
	49.420.000.02-2	8	Wide	



**SCREWS**

DYNAMIC SCREW	LENGTH	SCREWDRIVER
41.317.040.01-2	18	43.618.201.01-2
	24	43.624.201.01-2
	32	43.632.201.01-2



LIBRARY OPTIONS: GH = Gingival Height CH = Cement Height H = Height IG = Adaptor 3mm Gs = Standard maximum angulation Gc = Standard maximum angulation Gd = Direct to implant maximum angulation

# COMPATIBLE WITH O207

LIST OF COMPATIBILITIES **AVAILABLE**  
STRAUMANN

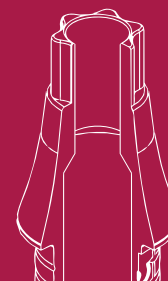
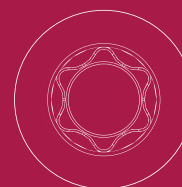

## STANDARD DYNAMIC TIBASE

GH (mm)	$\alpha_s$	$\alpha_c$	NON ENGAGING	ENGAGING
1,5	35°	15°	31.320.207.01-2	31.310.207.01-2
3	20°	-	31.320.207.03-2	31.310.207.03-2
4	15°	-	31.320.207.04-2	31.310.207.04-2



## DYNAMIC 3TIBASE

GH (mm)	$\alpha_s$ CH=5mm	$\alpha_s$ CH=7mm	$\alpha_s$ CH=9mm	NON ENGAGING	ENGAGING
1,5	25°	20°	15°	31.320.207.21-2	31.310.207.21-2
3	20°	15°	10°	31.320.207.23-2	31.310.207.23-2



## DYNAMIC SCANBODY (LAB/CLIN)

H (mm)	SCANBODY	ADAPTOR	SCREWDRIVER ADAPTOR
10	52.410.103.01-2	50.310.207.03-2 (IG=3mm)	43.621.410.01-2
12	52.412.103.01-2		43.624.410.01-2



### LAB SCANBODY

30.410.006.01-2



LIBRARY OPTIONS: GH = Gingival Height CH = Cement Height H = Height IG = Adaptor 3mm  $\alpha_s$  = Standard maximum angulation  $\alpha_c$  = Standard maximum angulation  $\alpha_d$  = Direct to implant maximum angulation

**DYNAMIC MILLING TOOL**

**ANALOG**

SHANK	$\alpha_{di}$	DYNAMIC MILLING TOOL	DIGITAL ANALOG
3		33.345.856.01-2*	34.610.207.01-2
4	30°	33.445.856.01-2*	
6		33.645.856.01-2*	



\*Only for R

**SCANBODY OP**

SCANBODY	PEEK PINS	HEIGHT	TYPE	SCREWDRIVER
54.315.207.21-2	49.414.000.01-2	6	A	43.601.107.01-2
	49.415.000.01-2	9	A	
	49.416.000.01-2	13	A	
	49.414.000.02-2	6	B	
	49.415.000.02-2	9	B	
	49.416.000.02-2	13	B	
	49.414.000.03-2	6	C	
	49.415.000.03-2	9	C	
	49.416.000.03-2	13	C	
	49.416.000.04-2	13	D	
49.416.000.05-2	13	E		



**SCREWS**

DYNAMIC SCREW	LENGTH	SCREWDRIVER
41.316.066.01-2	18	43.618.201.01-2
	24	43.624.201.01-2
	32	43.632.201.01-2



LIBRARY OPTIONS: GH = Gingival Height CH = Cement Height H = Height IG = Adaptor 3mm  $\alpha_s$  = Standard maximum angulation  $\alpha_d$  = Standard maximum angulation  $\alpha_i$  = Direct to implant maximum angulation

STRAIGHT SCREW	TYPE	SCREWDRIVER
40.316.007.03-2	TORX T6	43.601.107.01-2



## MULTI-UNIT

### STRAIGHT MULTI-UNIT

GH (mm)	NON ENGAGING
1	42.302.207.01-2
2	42.302.207.02-2
3	42.302.207.03-2
4	42.302.207.04-2



### ANGULATED MULTI-UNIT 20°

GH (mm)	ENGAGING
2,5/3,9	48.312.207.02-2
3,5/4,9	48.312.207.03-2
4,5/5,9	48.312.207.04-2



# COMPATIBLE WITH O2O8

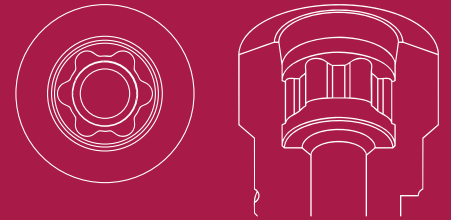

## LIST OF COMPATIBILITIES AVAILABLE

STRAUMANN

### STANDARD DYNAMIC TIBASE

GH (mm)	$\alpha_s$	$\alpha_c$	NON ENGAGING	ENGAGING
1,5	45°	20°	31.324.208.01-2	31.314.208.01-2



### DYNAMIC SCANBODY (LAB/CLIN)

H (mm)	SCANBODY	ADAPTOR	SCREWDRIVER ADAPTOR
10	52.410.103.01-2	50.310.207.03-2 (IG=3mm)	43.621.410.01-2
12	52.412.103.01-2		43.624.410.01-2



#### LAB SCANBODY

30.414.003.01-2



### DYNAMIC MILLING TOOL

SHANK	$\alpha_{di}$	DYNAMIC MILLING TOOL	DIGITAL ANALOG
3		33.345.856.01-2*	34.614.208.01-2
4	30°	33.445.856.01-2*	
6		33.645.856.01-2*	

\*Only for R



LIBRARY OPTIONS: GH = Gingival Height CH = Cement Height H = Height IG = Adaptor 3mm  $\alpha_s$  = Standard maximum angulation  $\alpha_c$  = Standard maximum angulation  $\alpha_{di}$  = Direct to implant maximum angulation

## SCANBODY OP

SCANBODY	PEEK PINS	HEIGHT	TYPE	SCREWDRIVER
54.315.207.21-2	49.414.000.01-2	6	A	43.601.107.01-2
	49.415.000.01-2	9	A	
	49.416.000.01-2	13	A	
	49.414.000.02-2	6	B	
	49.415.000.02-2	9	B	
	49.416.000.02-2	13	B	
	49.414.000.03-2	6	C	
	49.415.000.03-2	9	C	
	49.416.000.03-2	13	C	
	49.416.000.04-2	13	D	
49.416.000.05-2	13	E		



## SCREWS

DYNAMIC SCREW	LENGTH	SCREWDRIVER
41.316.066.01-2	18	43.618.201.01-2
	24	43.624.201.01-2
	32	43.632.201.01-2

STRAIGHT SCREW	TYPE	SCREWDRIVER
40.316.007.03-2	TORX T6	43.601.107.01-2



LIBRARY OPTIONS: GH = Gingival Height CH = Cement Height H = Height IG = Adaptor 3mm αs = Standard maximum angulation αc = Standard maximum angulation αd = Direct to implant maximum angulation

## MULTI-UNIT

### STRAIGHT MULTI-UNIT

GH (mm)	NON ENGAGING
1	42.302.207.01-2
2	42.302.207.02-2
3	42.302.207.03-2
4	42.302.207.04-2



### ANGULATED MULTI-UNIT 20°

GH (mm)	ENGAGING
2,5/3,9	48.312.207.02-2
3,5/4,9	48.312.207.03-2
4,5/5,9	48.312.207.04-2



# COMPATIBLE WITH O222

## LIST OF COMPATIBILITIES AVAILABLE

MEGAGEN

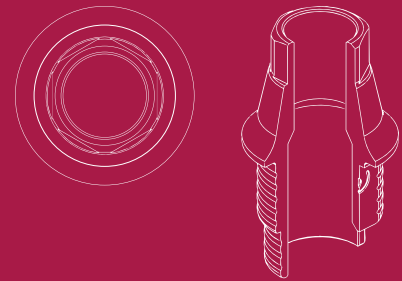

### STANDARD DYNAMIC TIBASE

GH (mm)	$\alpha_s$	$\alpha_c$	NON ENGAGING	ENGAGING
1	30°	-	31.320.222.01-2	31.310.222.01-2
2	25°	-	31.320.222.02-2	31.310.222.02-2
3	20°	-	31.320.222.03-2	31.310.222.03-2



#### LAB SCANBODY

30.410.006.01-2



### DYNAMIC MILLING TOOL

SHANK	$\alpha_{di}$	DYNAMIC MILLING TOOL
3		33.315.604.01-2
4	25°	33.415.604.01-2
6		33.615.604.01-2

### ANALOG

DIGITAL ANALOG
34.610.222.01-2



LIBRARY OPTIONS: GH = Gingival Height CH = Cement Height H = Height IG = Adaptor 3mm  $\alpha_s$  = Standard maximum angulation  $\alpha_c$  = Standard maximum angulation  $\alpha_{di}$  = Direct to implant maximum angulation

## SCANBODY OP

SCANBODY	PEEK PINS	HEIGHT	TYPE	SCREWDRIVER
54.315.222.21-2	49.414.000.01-2	6	A	43.601.103.02-2
	49.415.000.01-2	9	A	
	49.416.000.01-2	13	A	
	49.414.000.02-2	6	B	
	49.415.000.02-2	9	B	
	49.416.000.02-2	13	B	
	49.414.000.03-2	6	C	
	49.415.000.03-2	9	C	
	49.416.000.03-2	13	C	
	49.416.000.04-2	13	D	
49.416.000.05-2	13	E		



## SCREWS

DYNAMIC SCREW	LENGTH	SCREWDRIVER
41.316.078.02-2	18	43.618.201.01-2
	24	43.624.201.01-2
	32	43.632.201.01-2



# COMPATIBLE WITH O223

## LIST OF COMPATIBILITIES AVAILABLE

MEGAGEN

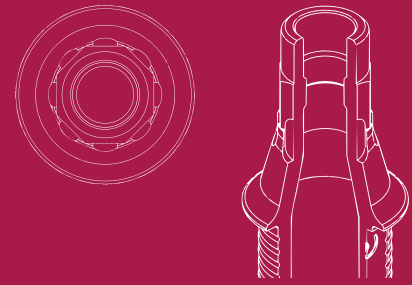

### STANDARD DYNAMIC TIBASE

GH (mm)	$\alpha_s$	$\alpha_c$	NON ENGAGING	ENGAGING
1	30°	-	31.323.223.01-2	31.313.223.01-2
2	25°	15°	31.323.223.02-2	31.313.223.02-2
3	20°	10°	31.323.223.03-2	31.313.223.03-2



#### LAB SCANBODY

30.413.002.01-2



### DYNAMIC MILLING TOOL

SHANK	$\alpha_{di}$	DYNAMIC MILLING TOOL
3		33.315.604.01-2
4	25°	33.415.604.01-2
6		33.615.604.01-2

### ANALOG

#### DIGITAL ANALOG

34.613.223.01-2



LIBRARY OPTIONS: GH = Gingival Height CH = Cement Height H = Height IG = Adaptor 3mm  $\alpha_s$  = Standard maximum angulation  $\alpha_c$  = Standard maximum angulation  $\alpha_{di}$  = Direct to implant maximum angulation

## SCANBODY OP

SCANBODY	PEEK PINS	HEIGHT	TYPE	SCREWDRIVER
54.315.223.21-2	49.414.000.01-2	6	A	43.601.103.02-2
	49.415.000.01-2	9	A	
	49.416.000.01-2	13	A	
	49.414.000.02-2	6	B	
	49.415.000.02-2	9	B	
	49.416.000.02-2	13	B	
	49.414.000.03-2	6	C	
	49.415.000.03-2	9	C	
	49.416.000.03-2	13	C	
	49.416.000.04-2	13	D	
49.416.000.05-2	13	E		



## SCREWS

DYNAMIC SCREW	LENGTH	SCREWDRIVER
41.316.078.02-2	18	43.618.201.01-2
	24	43.624.201.01-2
	32	43.632.201.01-2



# COMPATIBLE WITH O229

## LIST OF COMPATIBILITIES AVAILABLE

PALTOP

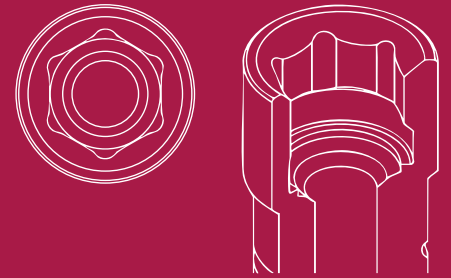

### STANDARD DYNAMIC TIBASE

GH (mm)	$\alpha_s$	$\alpha_c$	NON ENGAGING	ENGAGING
0,5	40°	-	31.320.229.01-2	31.310.229.01-2
<b>LAB SCANBODY</b>				
30.410.006.01-2				



### SCREWS

DYNAMIC SCREW	LENGTH	SCREWDRIVER
41.316.064.01-2	18	43.618.201.01-2
	24	43.624.201.01-2
	32	43.632.201.01-2



LIBRARY OPTIONS: GH = Gingival Height CH = Cement Height H = Height IG = Adaptor 3mm  $\alpha_s$  = Standard maximum angulation  $\alpha_c$  = Standard maximum angulation  $\alpha_d$  = Direct to implant maximum angulation

# COMPATIBLE WITH O236

LIST OF COMPATIBILITIES **AVAILABLE**  
ROOT

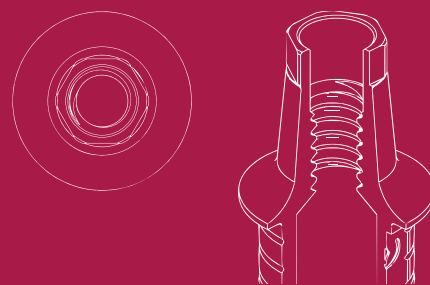

## STANDARD DYNAMIC TIBASE

GH (mm)	$\alpha_S$	$\alpha_C$	NON ENGAGING	ENGAGING
1,5	20°	25°	31.322.236.01-2	31.312.236.01-2



### LAB SCANBODY

30.412.001.01-2

## SCANBODY OP

SCANBODY	PEEK PINS	HEIGHT	TYPE	SCREWDRIVER
54.315.236.21-2	49.414.000.01-2	6	A	43.601.103.02-2
	49.415.000.01-2	9	A	
	49.416.000.01-2	13	A	
	49.414.000.02-2	6	B	
	49.415.000.02-2	9	B	
	49.416.000.02-2	13	B	
	49.414.000.03-2	6	C	
	49.415.000.03-2	9	C	
	49.416.000.03-2	13	C	
	49.416.000.04-2	13	D	
49.416.000.05-2	13	E		



LIBRARY OPTIONS: GH = Gingival Height CH = Cement Height H = Height IG = Adaptor 3mm  $\alpha_S$  = Standard maximum angulation  $\alpha_C$  = Standard maximum angulation  $\alpha_D$  = Direct to implant maximum angulation

**SCREWS**

DYNAMIC SCREW	LENGTH	SCREWDRIVER
	18	43.618.201.01-2
41.316.075.01-2	24	43.624.201.01-2
	32	43.632.201.01-2



# COMPATIBLE WITH O242

## LIST OF COMPATIBILITIES AVAILABLE

OXY

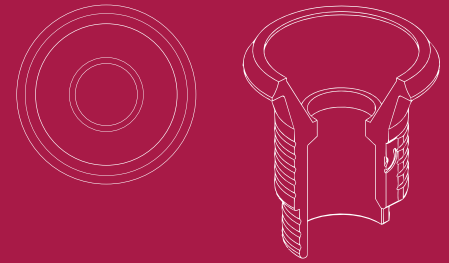

### STANDARD DYNAMIC TIBASE

GH (mm)	$\alpha_s$	$\alpha_c$	NON ENGAGING	ENGAGING
0,5	40°	-	31.323.242.01-2	-
<b>LAB SCANBODY</b>				
30.413.005.01-2				



### DYNAMIC MILLING TOOL

SHANK	$\alpha_{di}$	DYNAMIC MILLING TOOL
3		33.370.716.01-2
4	25°	33.470.716.01-2
6		33.670.716.01-2

### ANALOG

DIGITAL ANALOG
34.613.242.01-2



LIBRARY OPTIONS: GH = Gingival Height CH = Cement Height H = Height IG = Adaptor 3mm  $\alpha_s$  = Standard maximum angulation  $\alpha_c$  = Standard maximum angulation  $\alpha_{di}$  = Direct to implant maximum angulation

## SCANBODY REFERENCE

SCANBODY	PEEK PINS	HEIGHT	TYPE	SCREWDRIVER
	49.414.000.01-2	6	A	
	49.415.000.01-2	9	A	
	49.416.000.01-2	13	A	
	49.414.000.02-2	6	B	
	49.415.000.02-2	9	B	
	49.416.000.02-2	13	B	
	49.414.000.03-2	6	C	
	49.415.000.03-2	9	C	
	49.416.000.03-2	13	C	
54.322.242.31-2	49.416.000.04-2	13	D	43.601.104.01-2
	49.416.000.05-2	13	E	
	<b>CAPS</b>	<b>HEIGHT</b>	<b>TYPE</b>	
	49.418.000.01-2	3,8	Regular	
	49.418.000.02-2	3,8	Wide	
	49.419.000.01-2	6	Regular	
	49.419.000.02-2	6	Wide	
	49.420.000.01-2	8	Regular	
	49.420.000.02-2	8	Wide	



## SCREWS

DYNAMIC SCREW	DYNAMIC SCREW Ø2,6	LENGTH	SCREWDRIVER
		18	43.618.201.01-2
41.318.045.01-2	41.318.055.01-2 (Direct MU)	24	43.624.201.01-2
		32	43.632.201.01-2



# COMPATIBLE WITH O243

## LIST OF COMPATIBILITIES AVAILABLE

GMI (ILESIMPLANT)

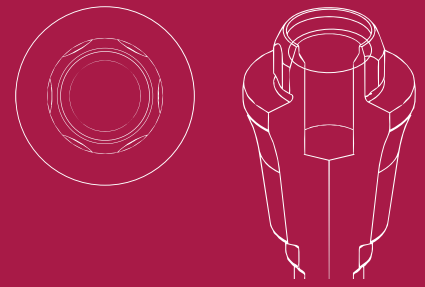

### SCREWS

DYNAMIC SCREW	LENTH	SCREWDRIVER
41.316.084.01-2	18	43.618.201.01-2
	24	43.624.201.01-2
	32	43.632.201.01-2

STRAIGHT SCREW	TYPE	SCREWDRIVER
40.316.003.01-2	Hex. 1.20	43.601.103.02-2



### MULTI-UNIT

#### STRAIGHT MULTI-UNIT

GH (mm)	NON ENGAGING
2	42.303.243.02-2
3	42.303.243.03-2



LIBRARY OPTIONS: GH = Gingival Height CH = Cement Height H = Height IG = Adaptor 3mm Gs = Standard maximum angulation Gc = Standard maximum angulation Gd = Direct to implant maximum angulation

# COMPATIBLE WITH O245

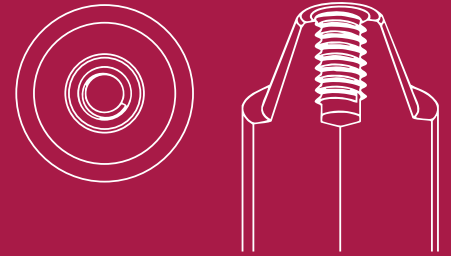

LIST OF COMPATIBILITIES **AVAILABLE**  
C-TECH

## STANDARD DYNAMIC TIBASE

GH (mm)	$\alpha_s$	$\alpha_c$	NON ENGAGING	ENGAGING
0,6	40°	-	31.323.245.01-2	-
<b>LAB SCANBODY</b>				
30.413.005.01-2				



## SCREWS

DYNAMIC SCREW	LENGTH	SCREWDRIVER
	18	43.618.201.01-2
41.314.039.01-2	24	43.624.201.01-2
	32	43.632.201.01-2



LIBRARY OPTIONS: GH = Gingival Height CH = Cement Height H = Height IG = Adaptor 3mm  $\alpha_s$  = Standard maximum angulation  $\alpha_c$  = Standard maximum angulation  $\alpha_d$  = Direct to implant maximum angulation

# COMPATIBLE WITH O246

LIST OF COMPATIBILITIES **AVAILABLE**  
C-TECH

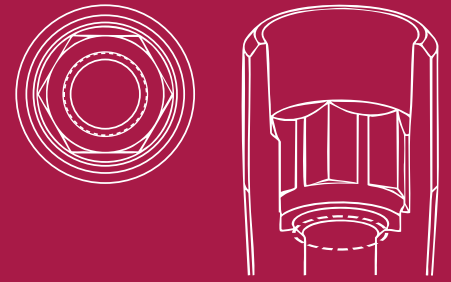

## STANDARD DYNAMIC TIBASE

GH (mm)	$\alpha_s$	$\alpha_c$	NON ENGAGING	ENGAGING
1	25°	-	31.322.246.01-2	31.312.246.01-2
2	25°	-	31.322.246.02-2	31.312.246.02-2
<b>LAB SCANBODY</b>				
30.412.001.01-2				



## SCREWS

DYNAMIC SCREW	LENGTH	SCREWDRIVER
41.318.080.01-2	18	43.618.201.01-2
	24	43.624.201.01-2
	32	43.632.201.01-2



LIBRARY OPTIONS: GH = Gingival Height CH = Cement Height H = Height IG = Adaptor 3mm  $\alpha_s$  = Standard maximum angulation  $\alpha_c$  = Standard maximum angulation  $\alpha_d$  = Direct to implant maximum angulation

# COMPATIBLE WITH O247

LIST OF COMPATIBILITIES **AVAILABLE**  
DIO IMPLANTS

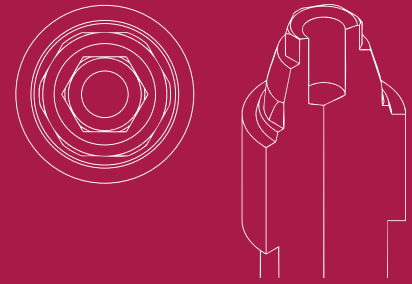

## STANDARD DYNAMIC TIBASE

GH (mm)	$\alpha_s$	$\alpha_c$	NON ENGAGING	ENGAGING
0,3	40°	-	31.323.247.01-2	-
<b>LAB SCANBODY</b>				
30.413.005.01-2				



## SCREWS

DYNAMIC SCREW	LENGTH	SCREWDRIVER
	18	43.618.201.01-2
41.316.040.01-2	24	43.624.201.01-2
	32	43.632.201.01-2



LIBRARY OPTIONS: GH = Gingival Height CH = Cement Height H = Height IG = Adaptor 3mm  $\alpha_s$  = Standard maximum angulation  $\alpha_c$  = Standard maximum angulation  $\alpha_d$  = Direct to implant maximum angulation

# COMPATIBLE WITH O249

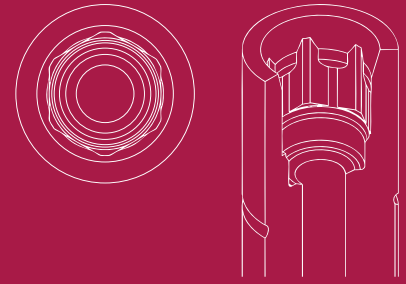

## LIST OF COMPATIBILITIES AVAILABLE

MEDENTIS

### STANDARD DYNAMIC TIBASE

GH (mm)	$\alpha_s$	$\alpha_c$	NON ENGAGING	ENGAGING
1	40°	-	31.320.249.01-2	31.310.249.01-2



### DYNAMIC SCANBODY (LAB/CLIN)

H (mm)	SCANBODY	ADAPTOR	SCREWDRIVER ADAPTOR
10	52.410.128.01-2	50.310.249.03-2 (IG=3mm)	43.621.415.01-2



#### LAB SCANBODY

30.410.006.01-2



### DYNAMIC MILLING TOOL

SHANK	$\alpha_{di}$	DYNAMIC MILLING TOOL	DIGITAL ANALOG
3		33.315.804.01-2	34.610.249.01-2
4	25°	33.415.804.01-2	
6		33.615.804.01-2	

### ANALOG



LIBRARY OPTIONS: GH = Gingival Height CH = Cement Height H = Height IG = Adaptor 3mm  $\alpha_s$  = Standard maximum angulation  $\alpha_c$  = Standard maximum angulation  $\alpha_{di}$  = Direct to implant maximum angulation

## SCREWS

DYNAMIC SCREW	LENGTH	SCREWDRIVER
	18	43.618.201.01-2
41.314.080.01-2	24	43.624.201.01-2
	32	43.632.201.01-2



STRAIGHT SCREW	TYPE	SCREWDRIVER
40.314.003.08-2	Hex 1,20	43.601.103.02-2



# COMPATIBLE WITH O251



## LIST OF COMPATIBILITIES AVAILABLE

BREXENT MEDICAL

### STANDARD DYNAMIC TIBASE

GH (mm)	$\alpha_s$	$\alpha_c$	NON ENGAGING	ENGAGING
1	40°	25°	31.322.251.01-2	31.312.251.01-2
1,5	40°	20°	31.322.251.02-2	31.312.251.02-2
3	25°	10°	31.322.251.04-2	31.312.251.04-2



#### LAB SCANBODY

30.412.001.01-2



### ANALOG

#### DIGITAL ANALOG

34.612.251.01-2



LIBRARY OPTIONS: GH = Gingival Height CH = Cement Height H = Height IG = Adaptor 3mm  $\alpha_s$  = Standard maximum angulation  $\alpha_c$  = Standard maximum angulation  $\alpha_d$  = Direct to implant maximum angulation

## SCANBODY OP

SCANBODY	PEEK PINS	HEIGHT	TYPE	SCREWDRIVER
54.315.251.21-2	49.414.000.01-2	6	A	43.601.107.01-2
	49.415.000.01-2	9	A	
	49.416.000.01-2	13	A	
	49.414.000.02-2	6	B	
	49.415.000.02-2	9	B	
	49.416.000.02-2	13	B	
	49.414.000.03-2	6	C	
	49.415.000.03-2	9	C	
	49.416.000.03-2	13	C	
	49.416.000.04-2	13	D	
49.416.000.05-2	13	E		



## SCREWS

DYNAMIC SCREW	LENGTH	SCREWDRIVER
41.316.064.02-2	18	43.618.201.01-2
	24	43.624.201.01-2
	32	43.632.201.01-2



STRAIGHT SCREW	TYPE	SCREWDRIVER
40.316.007.01-2	Hex 1,20	43.601.107.01-2



## MULTI-UNIT

### STRAIGHT MULTI-UNIT

GH (mm)	NON ENGAGING
1	42.302.251.01-2
2	42.302.251.02-2
3	42.302.251.03-2
4	42.302.251.04-2



# COMPATIBLE WITH O257

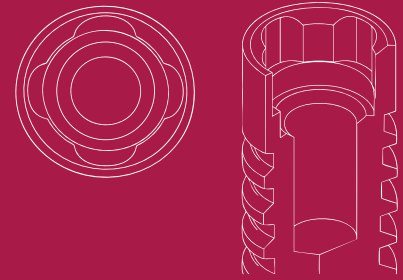

## LIST OF COMPATIBILITIES AVAILABLE

BTI

### SCREWS

DYNAMIC SCREW	LENGTH	SCREWDRIVER
41.318.065.01-2	18	43.618.201.01-2
	24	43.624.201.01-2
	32	43.632.201.01-2

STRAIGHT SCREW	TYPE	SCREWDRIVER
40.318.003.01-2	Hex. 1.20	43.601.103.02-2



### MULTI-UNIT

#### STRAIGHT MULTI-UNIT

GH (mm)	NON ENGAGING
1	42.302.257.01-2
2	42.302.257.02-2
3	42.302.257.03-2
4	42.302.257.04-2



LIBRARY OPTIONS: GH = Gingival Height CH = Cement Height H = Height IG = Adaptor 3mm Gs = Standard maximum angulation Gc = Standard maximum angulation Gd = Direct to implant maximum angulation

# COMPATIBLE WITH O258

## LIST OF COMPATIBILITIES AVAILABLE

ASTRA

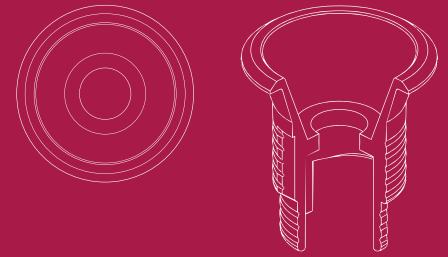

### STANDARD DYNAMIC TIBASE

GH (mm)	$\alpha_s$	$\alpha_c$	NON ENGAGING	ENGAGING
0,3	45°	30°	31.323.025.01-2	-



### DYNAMIC 3TIBASE

GH (mm)	$\alpha_s$ CH=5mm	$\alpha_s$ CH=7mm	$\alpha_s$ CH=9mm	NON ENGAGING	ENGAGING
0,3	30°	25°	10°	31.323.025.21-2	-



### DYNAMIC SCANBODY (LAB/CLIN)

H (mm)	SCANBODY	ADAPTOR	SCREWDRIVER ADAPTOR
8	52.408.112.01-2	50.313.025.02-2	43.621.410.01-2
10	52.410.111.01-2	50.313.025.01-2	43.624.410.01-2 43.620.411.01-2



LAB SCANBODY	MINI SCANBODY	SCANALOG
30.413.005.01-2	53.413.025.01-2	23.413.025.01-2



LIBRARY OPTIONS: GH = Gingival Height CH = Cement Height H = Height IG = Adaptor 3mm  $\alpha_s$  = Standard maximum angulation  $\alpha_c$  = Standard maximum angulation  $\alpha_d$  = Direct to implant maximum angulation

## DYNAMIC MILLING TOOL

## ANALOG

SHANK	$\alpha_{di}$	DYNAMIC MILLING TOOL	DIGITAL ANALOG	ANALOG
3		33.390.716.01-2	34.613.025.01-2	22.613.025.01-2
4	30°	33.490.716.01-2		
6		33.690.716.01-2		



## SCANBODY REFERENCE

SCANBODY	PEEK PINS	HEIGHT	TYPE	SCREWDRIVER
54.322.025.31-2	49.414.000.01-2	6	A	43.625.108.01-2
	49.415.000.01-2	9	A	
	49.416.000.01-2	13	A	
	49.414.000.02-2	6	B	
	49.415.000.02-2	9	B	
	49.416.000.02-2	13	B	
	49.414.000.03-2	6	C	
	49.415.000.03-2	9	C	
	49.416.000.03-2	13	C	
	49.416.000.04-2	13	D	
	49.416.000.05-2	13	E	
		CAPS	HEIGHT	
	49.418.000.01-2	3,8	Regular	
	49.418.000.02-2	3,8	Wide	
	49.419.000.01-2	6	Regular	
	49.419.000.02-2	6	Wide	
	49.420.000.01-2	8	Regular	
	49.420.000.02-2	8	Wide	



**SCREWS**

DYNAMIC SCREW	LENGTH	SCREWDRIVER
	18	43.618.201.01-2
41.314.039.01-2	24	43.624.201.01-2
	32	43.632.201.01-2



STRAIGHT SCREW	TYPE	SCREWDRIVER
40.314.005.04-2	Hex 1,27	43.625.105.01-2



# COMPATIBLE WITH O260

## LIST OF COMPATIBILITIES AVAILABLE

STRAUMANN

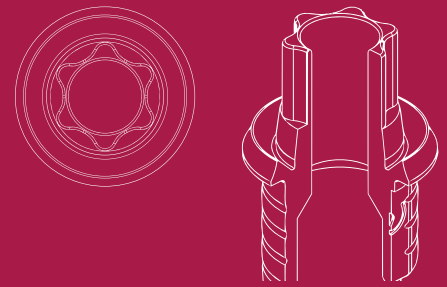

### STANDARD DYNAMIC TIBASE

GH (mm)	$\alpha_s$	$\alpha_c$	NON ENGAGING	ENGAGING
0,5	40°	-	31.320.260.01-2	31.310.260.01-2



### DYNAMIC SCANBODY (LAB/CLIN)

H (mm)	SCANBODY	ADAPTOR	SCREWDRIVER ADAPTOR
10	52.410.103.01-2	50.310.207.03-2 (IG=3mm)	43.621.410.01-2
12	52.412.103.01-2		43.624.410.01-2



LAB SCANBODY	SCANALOG
30.410.006.01-2	23.410.260.01-2



### DYNAMIC MILLING TOOL

SHANK	$\alpha_{di}$	DYNAMIC MILLING TOOL	DIGITAL ANALOG
3		33.345.856.01-2	34.610.260.01-2
4	30°	33.445.856.01-2	
6		33.645.856.01-2	

### ANALOG



LIBRARY OPTIONS: GH = Gingival Height CH = Cement Height H = Height IG = Adaptor 3mm  $\alpha_s$  = Standard maximum angulation  $\alpha_c$  = Standard maximum angulation  $\alpha_{di}$  = Direct to implant maximum angulation

## SCANBODY OP

SCANBODY	PEEK PINS	HEIGHT	TYPE	SCREWDRIVER
54.315.207.21-2	49.414.000.01-2	6	A	43.601.107.01-2
	49.415.000.01-2	9	A	
	49.416.000.01-2	13	A	
	49.414.000.02-2	6	B	
	49.415.000.02-2	9	B	
	49.416.000.02-2	13	B	
	49.414.000.03-2	6	C	
	49.415.000.03-2	9	C	
	49.416.000.03-2	13	C	
	49.416.000.04-2	13	D	
49.416.000.05-2	13	E		



## SCREWS

DYNAMIC SCREW	LENGTH	SCREWDRIVER
41.316.066.01-2	18	43.618.201.01-2
	24	43.624.201.01-2
	32	43.632.201.01-2



STRAIGHT SCREW	TYPE	SCREWDRIVER
40.316.007.03-2	TORX T6	43.601.107.01-2



## MULTI-UNIT

### STRAIGHT MULTI-UNIT

GH (mm)	NON ENGAGING
1	42.302.207.01-2
2	42.302.207.02-2
3	42.302.207.03-2
4	42.302.207.04-2



LIBRARY OPTIONS: GH = Gingival Height CH = Cement Height H = Height IG = Adaptor 3mm Gs = Standard maximum angulation Gc = Standard maximum angulation Gd = Direct to implant maximum angulation

# COMPATIBLE WITH O261

## LIST OF COMPATIBILITIES AVAILABLE

STRAUMANN

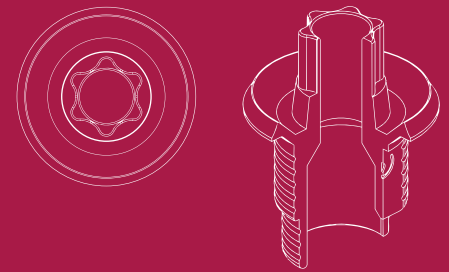

### STANDARD DYNAMIC TIBASE

GH (mm)	$\alpha_s$	$\alpha_c$	NON ENGAGING	ENGAGING
0,5	40°	-	31.323.261.01-2	31.313.261.01-2



### DYNAMIC SCANBODY (LAB/CLIN)

H (mm)	SCANBODY	ADAPTOR	SCREWDRIVER ADAPTOR
10	52.410.103.01-2	50.310.207.03-2 (IG=3mm)	43.621.410.01-2
12	52.412.103.01-2		43.624.410.01-2



LAB SCANBODY	SCANALOG
30.413.004.01-2	23.413.261.01-2



### DYNAMIC MILLING TOOL

SHANK	$\alpha_{di}$	DYNAMIC MILLING TOOL	DIGITAL ANALOG
3		33.345.856.01-2	34.613.261.01-2
4	30°	33.445.856.01-2	
6		33.645.856.01-2	



LIBRARY OPTIONS: GH = Gingival Height CH = Cement Height H = Height IG = Adaptor 3mm  $\alpha_s$  = Standard maximum angulation  $\alpha_c$  = Standard maximum angulation  $\alpha_{di}$  = Direct to implant maximum angulation

## SCANBODY OP

SCANBODY	PEEK PINS	HEIGHT	TYPE	SCREWDRIVER
54.315.207.21-2	49.414.000.01-2	6	A	43.601.107.01-2
	49.415.000.01-2	9	A	
	49.416.000.01-2	13	A	
	49.414.000.02-2	6	B	
	49.415.000.02-2	9	B	
	49.416.000.02-2	13	B	
	49.414.000.03-2	6	C	
	49.415.000.03-2	9	C	
	49.416.000.03-2	13	C	
	49.416.000.04-2	13	D	
49.416.000.05-2	13	E		



## SCREWS

DYNAMIC SCREW	LENGTH	SCREWDRIVER
41.316.066.01-2	18	43.618.201.01-2
	24	43.624.201.01-2
	32	43.632.201.01-2



STRAIGHT SCREW	TYPE	SCREWDRIVER
40.316.007.03-2	TORX T6	43.601.107.01-2



## MULTI-UNIT

### STRAIGHT MULTI-UNIT

GH (mm)	NON ENGAGING
1	42.302.207.01-2
2	42.302.207.02-2
3	42.302.207.03-2
4	42.302.207.04-2



LIBRARY OPTIONS: GH = Gingival Height CH = Cement Height H = Height IG = Adaptor 3mm Gs = Standard maximum angulation Gc = Standard maximum angulation Gd = Direct to implant maximum angulation

# COMPATIBLE WITH O262

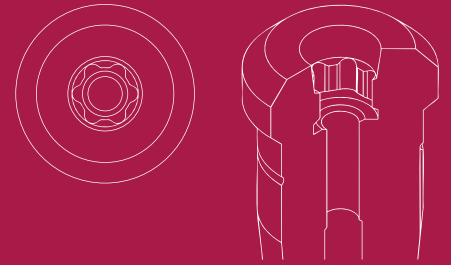

## LIST OF COMPATIBILITIES AVAILABLE

STRAUMANN

### STANDARD DYNAMIC TIBASE

GH (mm)	$\alpha_s$	$\alpha_c$	NON ENGAGING	ENGAGING
0,5	40°	-	31.324.262.01-2	31.314.262.01-2



### DYNAMIC SCANBODY (LAB/CLIN)

H (mm)	SCANBODY	ADAPTOR	SCREWDRIVER ADAPTOR
10	52.410.103.01-2	50.310.207.03-2 (IG=3mm)	43.621.410.01-2
12	52.412.103.01-2		43.624.410.01-2



#### LAB SCANBODY

30.414.008.01-2



### DYNAMIC MILLING TOOL

SHANK	$\alpha_{di}$	DYNAMIC MILLING TOOL	DIGITAL ANALOG
3		33.345.856.01-2	34.614.262.01-2
4	30°	33.445.856.01-2	
6		33.645.856.01-2	

### ANALOG



LIBRARY OPTIONS: GH = Gingival Height CH = Cement Height H = Height IG = Adaptor 3mm  $\alpha_s$  = Standard maximum angulation  $\alpha_c$  = Standard maximum angulation  $\alpha_{di}$  = Direct to implant maximum angulation

## SCANBODY OP

SCANBODY	PEEK PINS	HEIGHT	TYPE	SCREWDRIVER
54.315.207.21-2	49.414.000.01-2	6	A	43.601.107.01-2
	49.415.000.01-2	9	A	
	49.416.000.01-2	13	A	
	49.414.000.02-2	6	B	
	49.415.000.02-2	9	B	
	49.416.000.02-2	13	B	
	49.414.000.03-2	6	C	
	49.415.000.03-2	9	C	
	49.416.000.03-2	13	C	
	49.416.000.04-2	13	D	
49.416.000.05-2	13	E		



## SCREWS

DYNAMIC SCREW	LENGTH	SCREWDRIVER
41.316.066.01-2	18	43.618.201.01-2
	24	43.624.201.01-2
	32	43.632.201.01-2



STRAIGHT SCREW	TYPE	SCREWDRIVER
40.316.007.03-2	TORX T6	43.601.107.01-2



## MULTI-UNIT

### STRAIGHT MULTI-UNIT

GH (mm)	NON ENGAGING
1	42.302.207.01-2
2	42.302.207.02-2
3	42.302.207.03-2
4	42.302.207.04-2



LIBRARY OPTIONS: GH = Gingival Height CH = Cement Height H = Height IG = Adaptor 3mm Gs = Standard maximum angulation Gc = Standard maximum angulation Gd = Direct to implant maximum angulation

# COMPATIBLE WITH O264

## LIST OF COMPATIBILITIES AVAILABLE

MEGAGEN

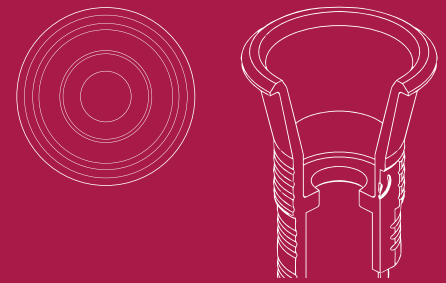

### DYNAMIC 3TIBASE

GH (mm)	$\alpha_s$	$\alpha_s$	$\alpha_s$	NON ENGAGING	ENGAGING
	CH=5mm	CH=7mm	CH=9mm		
0.3	-	25°	25°	31.323.264.21-2	-



#### MINI SCANBODY

53.413.264.01-2



### SCREWS

DYNAMIC SCREW	LENGTH	SCREWDRIVER
	18	43.618.201.01-2
41.314.044.02-2	24	43.624.201.01-2
	32	43.632.201.01-2



LIBRARY OPTIONS: GH = Gingival Height CH = Cement Height H = Height IG = Adaptor 3mm  $\alpha_s$  = Standard maximum angulation  $\alpha_c$  = Standard maximum angulation  $\alpha_d$  = Direct to implant maximum angulation

# COMPATIBLE WITH O265

LIST OF COMPATIBILITIES **AVAILABLE**

ALPHA-DENT - ANCLADEN - PROTEG IMPLANTS

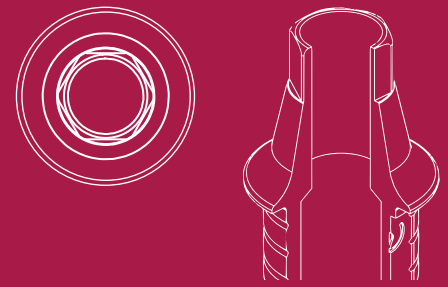

## STANDARD DYNAMIC TIBASE

GH (mm)	$\alpha_s$	$\alpha_c$	NON ENGAGING	ENGAGING
1,5	35°	-	31.322.265.03-2	31.312.265.03-2
2	25°	-	31.322.265.04-2	31.312.265.04-2
<b>LAB SCANBODY</b>				
30.412.001.01-2				



## SCREWS

DYNAMIC SCREW	LENGTH	SCREWDRIVER
	18	43.618.201.01-2
41.318.079.01-2	24	43.624.201.01-2
	32	43.632.201.01-2



LIBRARY OPTIONS: GH = Gingival Height CH = Cement Height H = Height IG = Adaptor 3mm  $\alpha_s$  = Standard maximum angulation  $\alpha_c$  = Standard maximum angulation  $\alpha_d$  = Direct to implant maximum angulation

# COMPATIBLE WITH O266



## LIST OF COMPATIBILITIES AVAILABLE

TBR

### STANDARD DYNAMIC TIBASE

GH (mm)	$\alpha_s$	$\alpha_c$	NON ENGAGING	ENGAGING
0,5	35°	-	31.320.266.01-2	31.310.266.01-2
2	25°	-	31.320.266.04-2	31.310.266.04-2



#### LAB SCANBODY

30.410.006.01-2



### SCREWS

DYNAMIC SCREW	LENGTH	SCREWDRIVER
41.320.068.01-2	18	43.618.201.01-2
	24	43.624.201.01-2
	32	43.632.201.01-2



LIBRARY OPTIONS: GH = Gingival Height CH = Cement Height H = Height IG = Adaptor 3mm  $\alpha_s$  = Standard maximum angulation  $\alpha_c$  = Standard maximum angulation  $\alpha_d$  = Direct to implant maximum angulation

# COMPATIBLE WITH O267

## LIST OF COMPATIBILITIES AVAILABLE

TBR

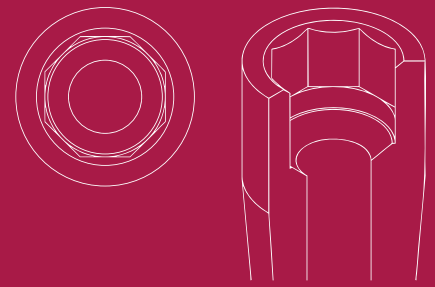

### STANDARD DYNAMIC TIBASE

GH (mm)	$\alpha_s$	$\alpha_c$	NON ENGAGING	ENGAGING
0,5	40°	-	31.322.267.01-2	31.312.267.01-2
<b>LAB SCANBODY</b>				
30.412.001.01-2				



### SCREWS

DYNAMIC SCREW	LENGTH	SCREWDRIVER
41.320.068.01-2	18	43.618.201.01-2
	24	43.624.201.01-2
	32	43.632.201.01-2



LIBRARY OPTIONS: GH = Gingival Height CH = Cement Height H = Height IG = Adaptor 3mm  $\alpha_s$  = Standard maximum angulation  $\alpha_c$  = Standard maximum angulation  $\alpha_d$  = Direct to implant maximum angulation

# COMPATIBLE WITH O268

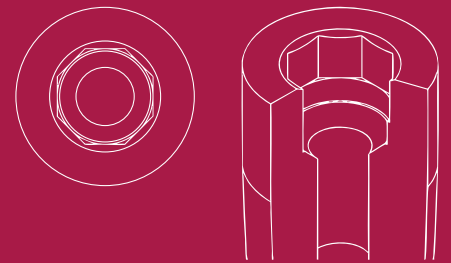

## LIST OF COMPATIBILITIES AVAILABLE

TBR

### STANDARD DYNAMIC TIBASE

GH (mm)	$\alpha_s$	$\alpha_c$	NON ENGAGING	ENGAGING
0,5	45°	-	31.323.268.01-2	31.313.268.01-2



#### LAB SCANBODY

30.413.002.01-2



### SCREWS

DYNAMIC SCREW	LENGTH	SCREWDRIVER
41.320.068.01-2	18	43.618.201.01-2
	24	43.624.201.01-2
	32	43.632.201.01-2



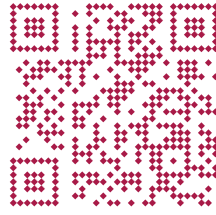

This printed version is probably outdated and may not include all products or compatibilities.

**Scan and download the latest version of this catalogue**

[www.dynamicabutment.com](http://www.dynamicabutment.com)

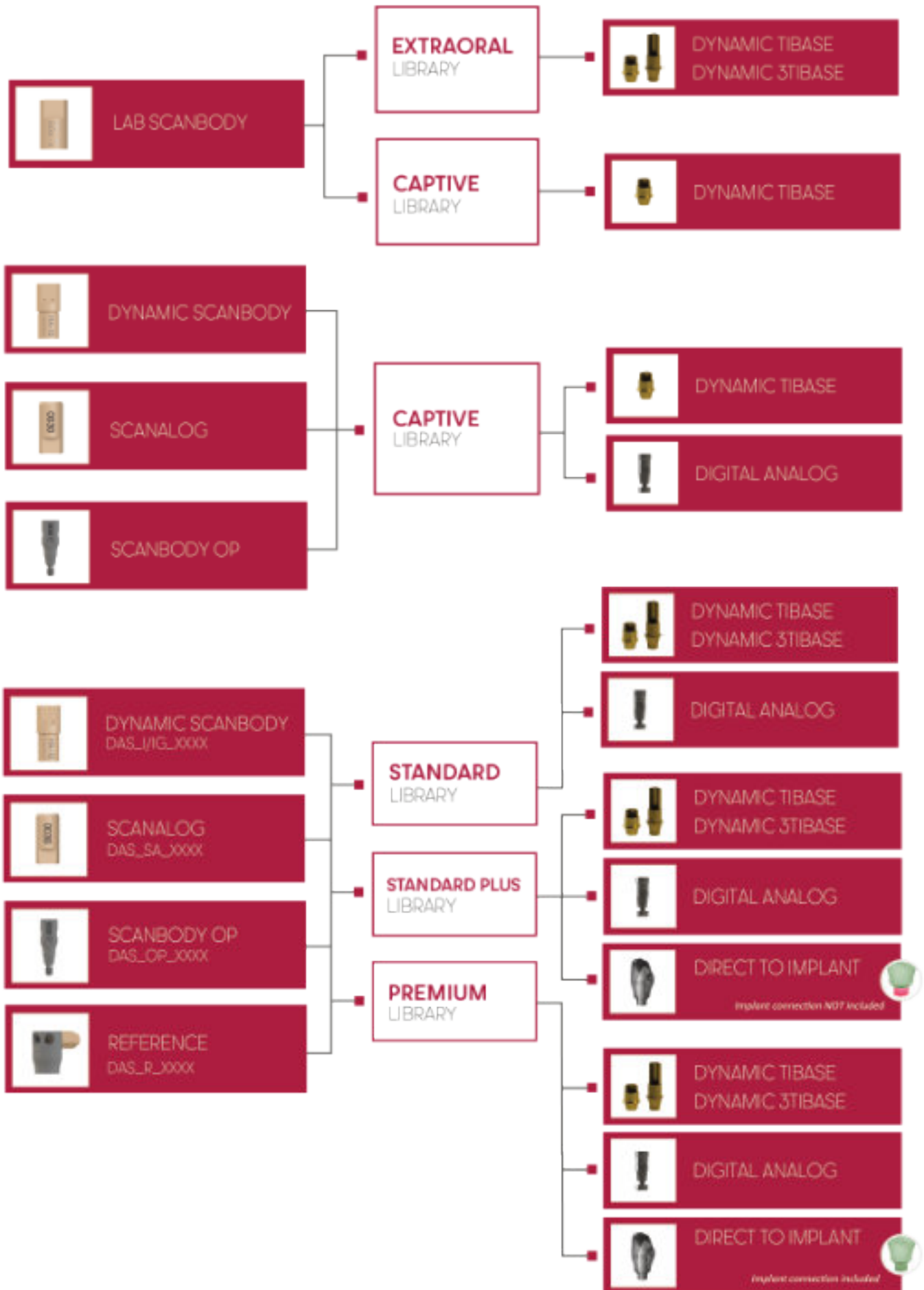

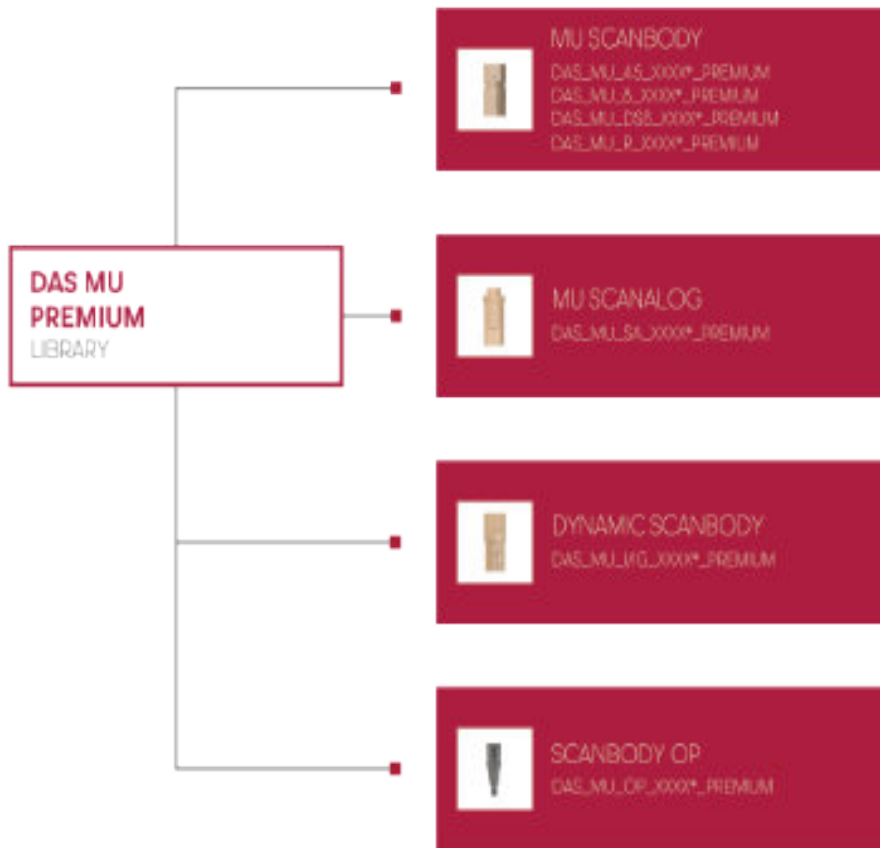

**DYNAMIC SCREWS** TECHNICAL SPECIFICATIONS  
**STRAIGHT SCREWS** TECHNICAL SPECIFICATIONS

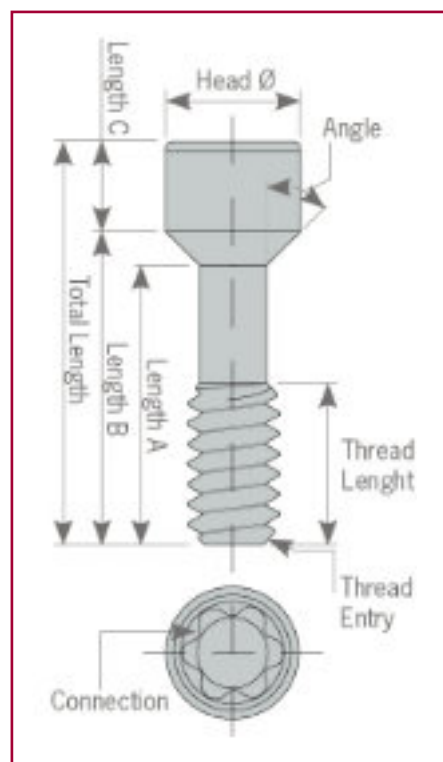
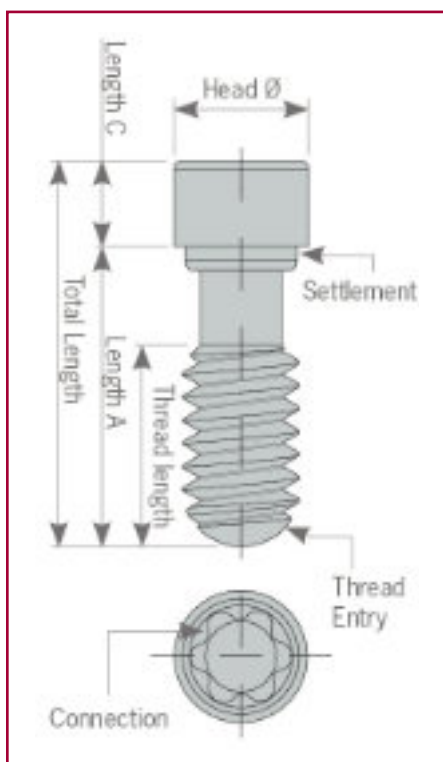

# DYNAMIC SCREWS TECHNICAL SPECIFICATIONS



REFERENCE	METRIC	TORQUE	TOTAL LENGTH	THREAD LENGTH	A LENGTH	B LENGTH	C LENGTH	HEAD DIAMETER	SEAT	ANGLE	THREAD ENTRY	CONNECTION
41.314.039.01-2	1.4	15 Ncm	3.9	1.8	2.1	-	1.8	2.4	straight	-	45° Chamfer	Hexalobular 1.70
41.314.040.02-2	1.4	15 Ncm	4	1.7	2.25	2.7	1.3	2.3	conical	45°	45° Chamfer	Hexalobular 1.70
41.314.043.01-2	1.4	15 Ncm	4.3	1.8	2.03	2.9	1.4	2.3	conical	35°	45° Chamfer	Hexalobular 1.70
41.314.044.01-2	1.4	15 Ncm	4.4	2.15	2.73	3	1.4	2.3	conical	60°	45° Chamfer	Hexalobular 1.70
41.314.046.01-2	1.4	15 Ncm	4.6	2.5	2.5	3.17	1.43	2.3	conical	35°	45° Chamfer	Hexalobular 1.70
41.314.064.01-2	1.4	15 Ncm	6.4	2.2	4.21	5.15	1.25	2.3	conical	25°	45° Chamfer	Hexalobular 1.70
41.314.067.02-2	1.4	15 Ncm	6.7	2.5	4.71	5.5	1.2	2.3	conical	35°	45° Chamfer	Hexalobular 1.70
41.314.070.01-2	1.4	15 Ncm	7	2.3	5.39	5.65	1.35	2.3	conical	60°	45° Chamfer	Hexalobular 1.70
41.314.074.01-2	1.4	15 Ncm	7.4	3.55	5	5.99	1.41	2.3	conical	25°	45° Chamfer	Hexalobular 1.70
41.314.076.01-2	1.4	15 Ncm	7.6	2.4	5.88	6.35	1.25	2.3	conical	45°	45° Chamfer	Hexalobular 1.70
41.314.080.01-2	1.4	15 Ncm	8	2.1	4.96	6.8	1.2	2.3	conical	15°	45° Chamfer	Hexalobular 1.70
41.314.084.01-2	1.4	15 Ncm	8.4	2.5	5.92	6.85	1.55	2.3	conical	35°	45° Chamfer	Hexalobular 1.70
41.314.105.01-2	1.4	15 Ncm	10.5	2.31	5	5.45	5.05	2.3	conical	45°	45° Chamfer	Hexalobular 1.70
41.315.078.01-2	No-80	15 Ncm	7.8	2.45	5.77	6	1.8	2.3	conical	65°	45° Chamfer	Hexalobular 1.70
41.316.040.01-2	1.6	20 Ncm	4	2.07	2.3	2.47	1.53	2.3	conical	60°	45° Chamfer	Hexalobular 1.70
41.316.048.01-2	1.6	20 Ncm	4.8	2.6	2.93	3.5	1.3	2.3	conical	45°	45° Chamfer	Hexalobular 1.70
41.316.048.02-2	1.6	20 Ncm	4.8	2.85	3	3.58	1.22	2.3	conical	31°	45° Chamfer	Hexalobular 1.70
41.316.064.01-2	1.6	20 Ncm	6.4	3.15	4.7	5	1.4	2.3	conical	60°	45° Chamfer	Hexalobular 1.70
41.316.064.02-2	1.6	20 Ncm	6.4	1.6	4.08	5.48	0.92	2.3	conical	15°	45° Chamfer	Hexalobular 1.70
41.316.066.01-2	1.6	20 Ncm	6.6	1.95	4.78	5.2	1.4	2.3	conical	45°	45° Chamfer	Hexalobular 1.70
41.316.071.01-2	1.6	20 Ncm	7.1	2.8	5.2	5.54	1.56	2.3	conical	60°	45° Chamfer	Hexalobular 1.70
41.316.072.01-2	1.6	20 Ncm	7.2	3.5	5.2	5.82	1.38	2.3	conical	30°	45° Chamfer	Hexalobular 1.70
41.316.073.01-2	1.6	20 Ncm	7.3	2.2	4.71	5.56	1.74	2.3	conical	35°	45° Chamfer	Hexalobular 1.70
41.316.076.01-2	1.6	20 Ncm	7.6	3.5	6.1	-	1.5	2.3	straight	-	Semi-sphere	Hexalobular 1.70
41.316.078.01-2	1.6	20 Ncm	7.84	2.2	5.51	7.04	0.8	2.3	conical	15°	45° Chamfer	Hexalobular 1.70
41.316.079.01-2	1.6	20 Ncm	7.9	2.30	5.42	6.60	1.3	2.3	conical	20°	45° Chamfer	Hexalobular 1.70
41.316.080.01-2	1.6	20 Ncm	8	3	6.3	6.51	1.49	2.3	conical	60°	45° Chamfer	Hexalobular 1.70
41.316.081.01-2	1.6	20 Ncm	8.1	3	6.35	6.73	1.37	2.3	conical	45°	45° Chamfer	Hexalobular 1.70
41.316.084.01-2	1.6	20 Ncm	8.4	3.5	6.8	-	1.6	2.3	straight	-	Semi-sphere	Hexalobular 1.70
41.316.084.02-2	1.6	20 Ncm	8.4	2.7	5.85	6.85	1.55	2.3	conical	30°	45° Chamfer	Hexalobular 1.70
41.316.086.01-2	1.6	20 Ncm	8.6	3	7.2	-	1.4	2.3	straight	-	45° Chamfer	Hexalobular 1.70
41.316.094.01-2	1.6	20 Ncm	9.4	2.9	7.62	8	1.4	2.3	conical	45°	45° Chamfer	Hexalobular 1.70
41.316.108.01-2	1.6	20 Ncm	10.8	2.2	4.72	5.56	5.24	2.3	conical	35°	45° Chamfer	Hexalobular 1.70
41.316.115.01-2	1.6	20 Ncm	11.5	3.5	5.2	5.82	5.68	2.3	conical	30°	45° Chamfer	Hexalobular 1.70
41.316.118.01-2	1.6	20 Ncm	11.8	3.5	6.1	-	5.7	2.3	straight	-	Semi-sphere	Hexalobular 1.70
41.316.124.01-2	1.6	20 Ncm	12.4	2.2	5.55	7.05	5.35	2.3	conical	15°	45° Chamfer	Hexalobular 1.70
41.316.132.01-2	1.6	20 Ncm	13.2	2.9	7.63	8	5.2	2.3	conical	45°	45° Chamfer	Hexalobular 1.70
41.317.040.01-2	N1-72	25 Ncm	4	2.1	2.5	-	1.5	2.3	straight	-	45° Chamfer	Hexalobular 1.70
41.317.041.01-2	N1-72	25Ncm	4.1	1.9	2.3	2.47	1.63	2.3	conical	55°	45° Chamfer	Hexalobular 1.70
41.317.065.01-2	N1-72	25 Ncm	6.5	2.4	4.7	5.18	1.33	2.3	conical	45°	45° Chamfer	Hexalobular 1.70
41.317.073.01-2	N1-72	25 Ncm	7.3	2.5	5.5	5.77	1.53	2.3	conical	60°	45° Chamfer	Hexalobular 1.70
41.317.106.01-2	N1-72	25 Ncm	10.6	2.8	5.54	5.65	4.95	2.3	conical	70°	Semi-sphere	Hexalobular 1.70
41.318.043.01-2	1.8	25 Ncm	4.3	2	2.52	2.7	1.6	2.3	conical	55°	45° Chamfer	Hexalobular 1.70
41.318.044.01-2	1.8	25 Ncm	4.4	2.75	3	-	1.4	2.3	straight	-	Semi-sphere	Hexalobular 1.70
41.318.045.01-2	1.8	25 Ncm	4.5	2.3	2.81	2.9	1.6	2.3	conical	70°	45° Chamfer	Hexalobular 1.70
41.318.051.01-2	1.8	25 Ncm	5.1	2.7	3.55	3.7	1.4	2.3	conical	60°	45° Chamfer	Hexalobular 1.70
41.318.064.01-2	1.8	25 Ncm	6.4	3.45	4.7	5.1	1.3	2.3	conical	35°	45° Chamfer	Hexalobular 1.70
41.318.065.01-2	1.8	25 Ncm	6.5	2.83	5	-	1.5	2.3	straight	-	Semi-sphere	Hexalobular 1.70
41.318.067.01-2	1.8	25 Ncm	6.7	2.35	4.93	5.4	1.3	2.3	conical	45°	45° Chamfer	Hexalobular 1.70
41.318.068.01-2	1.8	25 Ncm	6.8	4	5.25	5.4	1.4	2.3	conical	60°	45° Chamfer	Hexalobular 1.70
41.318.071.01-2	1.8	25 Ncm	7.1	2.6	5.54	5.65	1.45	2.3	conical	70°	45° Chamfer	Hexalobular 1.70
41.318.074.01-2	1.8	25 Ncm	7.4	3.8	5.8	6.04	1.36	2.3	conical	50°	45° Chamfer	Hexalobular 1.70
41.318.075.01-2	1.8	25 Ncm	7.5	3.3	6.1	-	1.4	2.3	straight	-	Semi-sphere	Hexalobular 1.70
41.318.076.01-2	1.8	25 Ncm	7.6	2.52	5.73	6.2	1.4	2.3	conical	45°	45° Chamfer	Hexalobular 1.70
41.318.077.01-2	1.8	25 Ncm	7.7	2.5	5.59	6.5	1.2	2.3	conical	30°	45° Chamfer	Hexalobular 1.70
41.318.077.02-2	1.8	25 Ncm	7.7	2.2	6.08	6.35	1.35	2.3	conical	60°	45° Chamfer	Hexalobular 1.70
41.318.080.01-2	1.8	25 Ncm	8	4	6.5	-	1.5	2.3	straight	-	45° Chamfer	Hexalobular 1.70
41.318.083.01-2	1.8	25 Ncm	8.3	4.25	6.79	6.95	1.35	2.3	conical	60°	45° Chamfer	Hexalobular 1.70
41.320.048.01-2	2	25 Ncm	4.8	2.7	3.3	3.4	1.4	2.3	conical	60°	45° Chamfer	Hexalobular 1.70
41.320.051.01-2	2	25 Ncm	5.1	3.1	3.6	-	1.5	2.3	straight	-	Semi-sphere	Hexalobular 1.70
41.320.060.01-2	2	25 Ncm	6	2.7	4.5	-	1.5	2.3	straight	-	Semi-sphere	Hexalobular 1.70
41.320.065.01-2	2	25 Ncm	6.5	2.7	5	-	1.5	2.3	straight	-	45° Chamfer	Hexalobular 1.70
41.320.068.01-2	2	25 Ncm	6.8	4.4	5.3	5.4	1.4	2.3	conical	60°	45° Chamfer	Hexalobular 1.70
41.320.090.01-2	2	25 Ncm	9	4	7.5	-	1.5	2.3	straight	-	Semi-sphere	Hexalobular 1.70
41.320.094.01-2	2	25 Ncm	9.4	3	7.84	8	1.4	2.3	conical	45°	45° Chamfer	Hexalobular 1.70

# DYNAMIC SCREWS TECHNICAL SPECIFICATIONS



REFERENCE	METRIC	TORQUE	TOTAL LENGTH	THREAD LENGTH	A LENGTH	B LENGTH	C LENGTH	HEAD DIAMETER	SEAT	ANGLE	THREAD ENTRY	CONNECTION
41.320.117.01-2	2	25 N·cm	11.7	2.75	5.91	6.18	5.52	2.3	conical	35°	Semi-sphere	Hexalobular 1.70
41.320.125.01-2	2	25 N·cm	12.5	3.3	6.33	6.5	6	2.3	conical	45°	45° Chamfer	Hexalobular 1.70
41.320.129.01-2	2	25 N·cm	12.9	4.7	6.7	-	6.2	2.4	straight	-	Semi-sphere	Hexalobular 1.70
41.320.137.01-2	2	25 N·cm	13.7	4	7.5	-	6.2	2.3	straight	-	Semi-sphere	Hexalobular 1.70
41.325.067.01-2	2.5	25 N·cm	6.7	4.6	5.1	-	1.6	2.85	straight	-	Semi-sphere	Hexalobular 1.70
41.318.051.01-2	1.8	25 N·cm	5.1	2.7	3.55	3.7	1.4	2.3	conical	60°	45° Chamfer	Hexalobular 1.70
41.318.051.02-2	1.8	25 N·cm	5.1	2.7	3.38	3.65	1.45	2.3	conical	45°	45° Chamfer	Hexalobular 1.70
41.318.064.01-2	1.8	25 N·cm	6.4	3.45	4.7	5.1	1.3	2.3	conical	35°	45° Chamfer	Hexalobular 1.70
41.318.067.01-2	1.8	25 N·cm	6.7	2.35	4.93	5.4	1.3	2.3	conical	45°	45° Chamfer	Hexalobular 1.70
41.318.069.01-2	1.8	25 N·cm	6.9	3.5	5.4	-	1.5	2.3	straight	-	45° Chamfer	Hexalobular 1.70
41.318.070.01-2	1.8	25 N·cm	7	3.4	5.303	5.7	1.3	2.3	conical	-	45° Chamfer	Hexalobular 1.70
41.318.071.01-2	1.8	25 N·cm	7.1	2.6	5.54	5.65	1.45	2.3	conical	70°	45° Chamfer	Hexalobular 1.70
41.318.074.01-2	1.8	25 N·cm	7.4	3.8	5.8	6.04	1.36	2.3	conical	50°	45° Chamfer	Hexalobular 1.70
41.318.076.01-2	1.8	25 N·cm	7.6	2.52	5.73	6.2	1.4	2.3	conical	45°	45° Chamfer	Hexalobular 1.70
41.318.077.01-2	1.8	25 N·cm	7.7	2.5	5.59	6.5	1.2	2.3	conical	30°	45° Chamfer	Hexalobular 1.70
41.318.079.01-2	1.8	25 N·cm	7.9	4	6.34	6.5	1.4	2.3	conical	60°	45° Chamfer	Hexalobular 1.70
41.318.080.01-2	1.8	25 N·cm	8	4	6.5	-	1.5	2.3	straight	-	45° Chamfer	Hexalobular 1.70
41.318.083.01-2	1.8	25 N·cm	8.3	4.25	6.79	6.95	1.35	2.3	conical	60°	45° Chamfer	Hexalobular 1.70
41.318.111.01-2	1.8	25 N·cm	11.1	2.2	6.06	6.35	4.75	2.3	conical	60°	45° Chamfer	Hexalobular 1.70
41.318.122.01-2	1.8	25 N·cm	12.2	3.8	5.8	6	6.2	2.3	conical	50°	45° Chamfer	Hexalobular 1.70
41.320.038.01-2	2	25 N·cm	3.81	2.35	2.35	2.42	1.39	2.35	conical	70°	45° Chamfer	Hexalobular 1.70
41.320.039.01-2	2	25 N·cm	3.9	1.9	2.41	2.5	1.4	2.3	conical	60°	45° Chamfer	Hexalobular 1.70
41.320.042.01-2	2	25 N·cm	4.2	2.2	3.1	-	1.1	2.315	straight	-	30° Chamfer	Hexalobular 1.70
41.320.043.01-2	2	25 N·cm	4.3	2	2.5	-	1.8	2.3	straight	-	45° Chamfer	Hexalobular 1.70
41.320.044.01-2	2	25 N·cm	4.4	2.45	2.95	3.1	1.3	2.3	conical	45°	45° Chamfer	Hexalobular 1.70
41.320.047.01-2	2	25 N·cm	4.7	3	3.3	-	1.4	2.3	straight	-	Semi-sphere	Hexalobular 1.70
41.320.048.01-2	2	25 N·cm	4.8	2.7	3.3	3.4	1.4	2.3	conical	60°	45° Chamfer	Hexalobular 1.70
41.320.050.01-2	2	25 N·cm	5	2.8	3.35	3.6	1.4	2.3	conical	31°	Semi-sphere	Hexalobular 1.70
41.320.050.02-2	2	25 N·cm	5	3	3.5	-	1.5	1.5	straight	-	45° Chamfer	Hexalobular 1.70
41.320.051.01-2	2	25 N·cm	5.1	3.1	3.6	-	1.5	2.3	straight	-	Semi-sphere	Hexalobular 1.70
41.320.052.01-2	2	25 N·cm	5.2	3	3.7	-	1.5	2.6	straight	-	30° Chamfer	Hexalobular 1.70
41.320.060.01-2	2	25 N·cm	6	2.7	4.5	-	1.5	2.3	straight	-	Semi-sphere	Hexalobular 1.70
41.320.065.01-2	2	25 N·cm	6.5	2.7	5	-	1.5	2.3	straight	-	45° Chamfer	Hexalobular 1.70
41.320.067.01-2	2	25 N·cm	6.7	2.3	3.59	5.7	1	2.58	conical	15°	45° Chamfer	Hexalobular 1.70
41.320.068.01-2	2	25 N·cm	6.8	4.4	5.3	5.4	1.4	2.3	conical	60°	45° Chamfer	Hexalobular 1.70
41.320.070.01-2	2	25 N·cm	7	3	5.6	-	1.4	2.3	straight	-	Semi-sphere	Hexalobular 1.70
41.320.071.01-2	2	25 N·cm	7.1	4	5.11	5.55	1.55	2.3	conical	20°	45° Chamfer	Hexalobular 1.70
41.320.074.01-2	2	25 N·cm	7.4	3.3	6	-	1.4	2.3	straight	-	Semi-sphere	Hexalobular 1.70
41.320.075.01-2	2	25 N·cm	7.5	2.75	5.9	6.19	1.31	2.3	conical	35°	Semi-sphere	Hexalobular 1.70
41.320.079.01-2	2	25 N·cm	7.9	3.3	6.32	6.5	1.4	2.3	conical	45°	45° Chamfer	Hexalobular 1.70
41.320.081.01-2	2	25 N·cm	8.1	4.6	5.53	5.8	2.3	2.3	conical	65°	45° Chamfer	Hexalobular 1.70
41.320.082.01-2	2	25 N·cm	8.2	4.7	6.7	-	1.5	2.4	straight	-	Semi-sphere	Hexalobular 1.70
41.320.090.01-2	2	25 N·cm	9	4	7.5	-	1.5	2.3	straight	-	Semi-sphere	Hexalobular 1.70
41.320.094.01-2	2	25 N·cm	9.4	3	7.84	8	1.4	2.3	conical	45°	45° Chamfer	Hexalobular 1.70
41.320.094.02-2	2	25 N·cm	9.4	3	7.9	-	1.5	2.3	straight	-	Semi-sphere	Hexalobular 1.70
41.320.117.01-2	2	25 N·cm	11.7	2.75	5.91	6.18	5.52	2.3	conical	35°	Semi-sphere	Hexalobular 1.70
41.320.125.01-2	2	25 N·cm	12.5	3.3	6.33	6.5	6	2.3	conical	45°	45° Chamfer	Hexalobular 1.70
41.320.129.01-2	2	25 N·cm	12.9	4.7	6.7	-	6.2	2.4	straight	-	Semi-sphere	Hexalobular 1.70
41.320.137.01-2	2	25 N·cm	13.7	4	7.5	-	6.2	2.3	straight	-	Semi-sphere	Hexalobular 1.70
41.325.054.01-2	2.5	25 N·cm	5.4	4.6	4.1	-	1.3	2.865	straight	-	Semi-sphere	Hexalobular 1.70
41.325.067.01-2	2.5	25 N·cm	6.7	4.6	5.1	-	1.6	2.85	straight	-	Semi-sphere	Hexalobular 1.70

# STRARICHT SCREWS TECHNICAL SPECIFICATIONS



REFERENCE	METRIC	TORQUE	TOTAL LENGTH	THREAD LENGTH	A LENGTH	B LENGTH	C LENGTH	HEAD DIAMETER	SEAT	ANGLE	THREAD ENTRY	CONNECTION
40.312.003.01-2	1.2	0.25	15 Ncm	7.85	2.7	6.2	6.55	1.3	1.9	conical	45° Chamfer	Hex. 1.20
40.314.003.01-2	1.4	0.3	15 Ncm	3.9	1.91	2.1	-	1.8	2.4	straight	45° Chamfer	Hex. 1.20
40.314.003.02-2	1.4	0.3	15 Ncm	4	2	2.2	-	1.8	2.3	straight	45° Chamfer	Hex. 1.20
40.314.003.03-2	1.4	0.3	15 Ncm	7.6	2.4	6.05	6.3	1.3	1.9	conical	45° Chamfer	Hex. 1.20
40.314.003.04-2	1.4	0.3	15 Ncm	7.5	2.5	5.45	5.7	1.8	1.85	conical	45° Chamfer	Hex. 1.20
40.314.003.05-2	1.4	0.3	15 Ncm	5.3	1.34	3.7	-	1.6	2.1	straight	30° Chamfer	Hex. 1.25
40.314.004.01-2	1.4	0.3	15 Ncm	6.3	2.2	4.6	5.1	1.2	2.1	conical	30° Chamfer	Hex. 1.25
40.314.005.01-2	1.4	0.3	15 Ncm	7.6	3.6	5.21	6	1.6	2.15	conical	45° Chamfer	Hex. 1.27
40.314.005.02-2	1.4	0.3	15 Ncm	7.5	2.4	5.5	5.7	1.8	2.1	conical	45° Chamfer	Hex. 1.27
40.314.005.04-2	1.4	0.3	15 Ncm	4	1.7	2.25	-	1.75	2.1	straight	45° Chamfer	Hex. 1.27
40.314.007.01-2	1.4	0.3	15 Ncm	4	1.8	2.01	2.8	1.2	2.2	conical	45° Chamfer	Torx T6
40.314.007.02-2	1.4	0.3	15 Ncm	7	2.1	6.2	2.25	0.8	2.1	conical	45° Chamfer	Torx T6
40.314.007.03-2	1.4	0.3	15 Ncm	5.1	1.1	3.35	3.9	1.2	2.1	conical	45° Chamfer	Torx T6
40.314.008.01-2	1.4	0.3	15 Ncm	3.6	1.8	2.1	-	1.5	2.1	straight	45° Chamfer	Unigrip
40.314.008.02-2	1.4	0.3	15 Ncm	6.7	2.5	4.87	5.3	1.4	1.8	conical	45° Chamfer	Unigrip
40.314.008.03-2	1.4	0.3	15 Ncm	6.65	1.6	3.65	5.75	0.9	2.95	conical	45° Chamfer	Unigrip
40.314.008.04-2	1.4	0.3	15 Ncm	4.8	1.1	3.05	3.6	1.2	2.1	conical	45° Chamfer	Unigrip
40.314.012.01-2	1.4	0.3	15 Ncm	4.5	1.7	2.01	2.4	2.1	2.15	conical	45° Chamfer	Star 1.50
40.314.014.01-2	1.4	0.3	15 Ncm	4.45	2.3	2.48	-	1.97	2.16	straight	45° Chamfer	Hex. 1.19
40.315.008.01-2	No-80	0.317	15 Ncm	8.3	2.45	5.79	5.95	2.35	2	conical	45° Chamfer	Unigrip
40.316.002.01-2	1.6	0.35	20 Ncm	7	2.79	4.86	5.44	1.56	2.3	conical	45° Chamfer	Cuad. 1.30
40.316.002.02-2	1.6	0.35	20 Ncm	9.3	3.3	7.3	-	2	2.3	straight	Semi-sphere	Cuad. 1.30
40.316.003.01-2	1.6	0.35	20 Ncm	8.4	2.5	6.6	-	1.8	2	straight	45° Chamfer	Hex. 1.20
40.316.003.02-2	1.6	0.35	20 Ncm	10.2	2	7.88	8.2	2	2.2	conical	45° Chamfer	Hex. 1.20
40.316.004.02-2	1.6	0.35	20 Ncm	8.8	3	6.73	7	1.8	2.1	conical	45° Chamfer	Hex. 1.25
40.316.004.03-2	1.6	0.35	20 Ncm	6.9	2.2	5.02	5.2	1.7	1.92	conical	45° Chamfer	Hex. 1.25
40.316.005.01-2	1.6	0.35	20 Ncm	7.5	3.6	5.44	5.9	1.6	2.13	conical	45° Chamfer	Hex. 1.27
40.316.005.02-2	1.6	0.35	20 Ncm	8.25	3	6.25	-	2	2.33	straight	45° Chamfer	Hex. 1.27
40.316.005.03-2	1.6	0.35	20 Ncm	8.25	3.03	6.25	-	2	2.45	straight	45° Chamfer	Hex. 1.27
40.316.005.04-2	1.6	0.35	20 Ncm	10.5	3.2	8.15	8.4	2.1	2.1	conical	45° Chamfer	Hex. 1.27
40.316.005.05-2	1.6	0.35	20 Ncm	7.6	2.7	5.21	5.5	2.1	2.1	conical	45° Chamfer	Hex. 1.27
40.316.005.06-2	1.6	0.35	20 Ncm	3.8	1.8	2.2	-	1.6	2.1	straight	45° Chamfer	Hex. 1.27
40.316.005.07-2	1.6	0.35	20 Ncm	8.8	2.85	6.73	6.9	1.9	2.15	conical	45° Chamfer	Hex. 1.27
40.316.005.08-2	1.6	0.35	20 Ncm	9	3.9	6.49	6.9	2.1	2.18	conical	45° Chamfer	Hex. 1.27
40.316.005.09-2	1.6	0.35	20 Ncm	8.5	1.6	6.46	7	1.5	2.2	conical	45° Chamfer	Hex. 1.27
40.316.007.01-2	1.6	0.35	20 Ncm	7.9	2	5.63	6.9	1	2.18	conical	45° Chamfer	Torx T6
40.316.007.02-2	1.6	0.35	20 Ncm	9	1.6	6.96	7.5	1.5	2.2	conical	45° Chamfer	Torx T6
40.316.008.02-2	1.6	0.35	20 Ncm	7.3	2.7	5.15	5.9	1.4	2.2	conical	45° Chamfer	Unigrip
40.316.008.03-2	1.6	0.35	20 Ncm	8.5	1.6	6.46	7	1.5	2.2	conical	45° Chamfer	Unigrip
40.316.012.01-2	1.6	0.35	20 Ncm	8	2.65	5.53	6	2	2.15	conical	45° Chamfer	Star 1.50
40.316.014.01-2	1.6	0.35	20 Ncm	7.9	2.3	5.42	6.46	1.44	2.2	conical	45° Chamfer	Hex. 1.19
40.317.002.01-2	N1-72	0.353	25 Ncm	8.17	3	5.31	5.87	2.3	2.4	conical	45° Chamfer	Cuad. 1.30
40.317.004.01-2	N1-72	0.353	25 Ncm	7.6	2.8	5.6	5.77	1.83	2.3	conical	45° Chamfer	Hex. 1.27
40.317.005.01-2	N1-72	0.353	25 Ncm	7.6	2.15	5.17	5.4	2.2	2.2	conical	45° Chamfer	Hex. 1.27
40.317.005.02-2	N1-72	0.353	25 Ncm	7.3	2.4	4.73	5.25	2.05	2.4	conical	45° Chamfer	Hex. 1.27
40.318.002.01-2	1.8	0.35	25 Ncm	7	3.2	5.2	-	1.8	2.5	straight	45° Chamfer	Cuad. 1.30
40.318.002.02-2	1.8	0.35	25 Ncm	8.3	2.6	6.6	-	1.7	2.45	straight	45° Chamfer	Cuad. 1.30
40.318.003.01-2	1.8	0.35	25 Ncm	6.8	3.3	5.2	-	1.6	2.3	straight	45° Chamfer	Hex. 1.20
40.318.003.02-2	1.8	0.35	25 Ncm	8	3.6	6	-	2	2.1	straight	45° Chamfer	Hex. 1.20
40.318.004.01-2	1.8	0.35	25 Ncm	7.2	4.8	5.36	5.9	1.3	2.4	conical	45° Chamfer	Hex. 1.25
40.318.004.02-2	1.8	0.35	25 Ncm	9.8	5.8	7.96	8.5	1.3	2.4	conical	45° Chamfer	Hex. 1.25
40.318.004.03-2	1.8	0.35	25 Ncm	7.65	3.3	5.17	5.75	1.9	2.4	conical	45° Chamfer	Hex. 1.25
40.318.005.01-2	1.8	0.35	25 Ncm	4.5	2.3	2.8	2.9	1.6	2.33	conical	45° Chamfer	Hex. 1.27
40.318.005.02-2	1.8	0.35	25 Ncm	7.6	3.6	5.76	6	1.6	2.33	conical	45° Chamfer	Hex. 1.27
40.318.005.03-2	1.8	0.35	25 Ncm	8.5	1.6	6.56	7	1.5	2.2	conical	45° Chamfer	Hex. 1.27
40.318.005.04-2	1.8	0.35	25 Ncm	5.2	1.6	3.41	3.8	1.4	2.2	conical	45° Chamfer	Hex. 1.27
40.318.006.01-2	1.8	0.35	25 Ncm	6	3	3.67	4	2	2.4	conical	45° Chamfer	Hex. 1.70
40.318.007.01-2	1.8	0.35	25 Ncm	9.1	4.25	7.32	7.45	1.65	2.18	conical	45° Chamfer	Torx T6
40.318.008.01-2	1.8	0.35	25 Ncm	8.3	2.5	6.5	-	1.8	2.45	straight	45° Chamfer	Unigrip
40.318.012.01-2	1.8	0.35	25 Ncm	7.25	2.4	4.93	5.25	2	2.15	conical	45° Chamfer	Star 1.50
40.318.012.02-2	1.8	0.35	25 Ncm	8	2.6	5.68	6	2	2.15	conical	45° Chamfer	Star 1.50

# STRARICHT SCREWS TECHNICAL SPECIFICATIONS



REFERENCE	METRIC	TORQUE	TOTAL LENGTH	THREAD LENGTH	A LENGTH	B LENGTH	C LENGTH	HEAD DIAMETER	SEAT	ANGLE	THREAD ENTRY	CONNECTION
40.318.013.01-2	1.8	0.35	25 Ncm	7.7	2.5	5.7	6.4	1.3	2.2	conical	45° Chamfer	Hex. 1.00
40.320.002.01-2	2	0.4	30 Ncm	4.9	3.26	3.26	3.5	1.4	2.49	conical	45° Chamfer	Cuad. 1.30
40.320.002.02-2	2	0.4	30 Ncm	7.45	3	5.7	5.9	1.5	2.4	conical	45° Chamfer	Cuad. 1.30
40.320.002.03-2	2	0.4	30 Ncm	10.2	3.15	8.4	-	1.8	2.45	straight	45° Chamfer	Cuad. 1.30
40.320.003.01-2	2	0.4	30 Ncm	4.7	3	3.33	-	1.37	2.35	straight	45° Chamfer	Hex. 1.20
40.320.003.02-2	2	0.4	30 Ncm	7	3.25	5	-	2	2.4	straight	45° Chamfer	Hex. 1.20
40.320.003.03-2	2	0.4	30 Ncm	7.9	3.7	5.55	6.05	1.85	2.4	conical	45° Chamfer	Hex. 1.20
40.320.003.04-2	2	0.4	30 Ncm	8.4	2.75	5.68	6.35	2.05	2.3	conical	45° Chamfer	Hex. 1.20
40.320.003.05-2	2	0.4	30 Ncm	4.8	3.3	3.65	3.9	0.9	2.45	conical	45° Chamfer	Hex. 1.20
40.320.003.06-2	2	0.25	25 Ncm	4	2	2.5	-	1.5	2.3	straight	30° Chamfer	Hex. 1.20
40.320.003.07-2	2	0.25	25 Ncm	8.5	1.6	6.63	7	1.5	2.2	conical	45° Chamfer	Hex. 1.20
40.320.005.01-2	2	0.4	30 Ncm	7.6	3.7	6	-	1.6	2.33	straight	45° Chamfer	Hex. 1.27
40.320.005.02-2	2	0.4	30 Ncm	10.3	4	8.3	-	2	2.45	straight	45° Chamfer	Hex. 1.27
40.320.005.03-2	2	0.4	30 Ncm	10.3	3.5	8.3	-	2	2.33	straight	45° Chamfer	Hex. 1.27
40.320.005.04-2	2	0.4	30 Ncm	10.5	3.2	8.15	8.4	2.1	2.5	conical	45° Chamfer	Hex. 1.27
40.320.007.01-2	2	0.4	30 Ncm	6.7	2.25	3.59	5.7	1	2.58	conical	45° Chamfer	Torx T6
40.320.007.02-2	2	0.4	30 Ncm	7.4	3.3	6	-	1.4	2.3	straight	Semi-sphere	Torx T6
40.320.007.03-2	2	0.4	30 Ncm	7.4	2.8	5.9	6.1	1.3	2.4	conical	Semi-sphere	Torx T6
40.320.007.04-2	2	0.4	30 Ncm	4.6	2.96	3.21	3.5	1.1	2.45	conical	45° Chamfer	Torx T6
40.320.007.05-2	2	0.25	25 Ncm	5	3	3.5	-	1.5	2.6	straight	30° Chamfer	Torx T6
40.320.008.01-2	2	0.4	30 Ncm	7	3.25	5	-	2	2.4	straight	45° Chamfer	Unigrip
40.320.008.02-2	2	0.4	30 Ncm	7.3	3	5.8	6.2	1.1	2.5	conical	45° Chamfer	Unigrip
40.320.008.03-2	2	0.4	30 Ncm	10	3.1	8.5	-	1.5	2.45	straight	45° Chamfer	Unigrip
40.320.008.04-2	2	0.4	30 Ncm	8.5	1.6	6.63	7	1.5	2.2	conical	45° Chamfer	Unigrip
40.325.002.01-2	2.5	0.45	30 Ncm	7.41	3.5	4.75	5.29	2.12	2.87	conical	Semi-sphere	Cuad. 1.30
40.325.008.01-2	2.5	0.45	30 Ncm	7	2.8	5.6	-	1.4	3.4	straight	45° Chamfer	Unigrip
40.320.003.01-2	2	0.4	30 Ncm	4.7	3	3.33	-	1.37	2.35	straight	45° Chamfer	Hex. 1.20
40.320.003.02-2	2	0.4	30 Ncm	7	3.25	5	-	2	2.4	straight	45° Chamfer	Hex. 1.20
40.320.003.03-2	2	0.4	30 Ncm	7.9	3.7	5.55	6.05	1.85	2.4	conical	45° Chamfer	Hex. 1.20
40.320.003.04-2	2	0.4	30 Ncm	8.4	2.75	5.68	6.35	2.05	2.3	conical	45° Chamfer	Hex. 1.20
40.320.003.05-2	2	0.4	30 Ncm	4.8	3.3	3.65	3.9	0.9	2.45	conical	45° Chamfer	Hex. 1.20
40.320.003.06-2	2	0.25	25 Ncm	4	2	2.5	-	1.5	2.3	straight	30° Chamfer	Hex. 1.20
40.320.003.07-2	2	0.25	25 Ncm	8.5	1.6	6.63	7	1.5	2.2	conical	45° Chamfer	Hex. 1.20
40.320.003.08-2	2	0.4	25 Ncm	4.2	2.2	2.7	-	1.5	2.3	straight	30° Chamfer	Hex. 1.20
40.320.005.01-2	2	0.4	30 Ncm	7.6	3.7	6	-	1.6	2.33	straight	45° Chamfer	Hex. 1.27
40.320.005.02-2	2	0.4	30 Ncm	10.3	4	8.3	-	2	2.45	straight	45° Chamfer	Hex. 1.27
40.320.005.03-2	2	0.4	30 Ncm	10.3	3.5	8.3	-	2	2.33	straight	45° Chamfer	Hex. 1.27
40.320.005.04-2	2	0.4	30 Ncm	10.5	3.2	8.15	8.4	2.1	2.5	conical	45° Chamfer	Hex. 1.27
40.320.005.05-2	2	0.4	25 Ncm	9	2.15	6.93	7.3	1.7	2.2	conical	45° Chamfer	Hex. 1.27

## SCREWDRIVERS



## STRAIGHT SCREWS

Straight screws cover all the thread metrics available on the market. We have several lengths for each metric to make the adaptation to the milled structures easier.



# DYNAMIC MILLING TOOL SPECIFICATIONS



MAIN COMPATIBILITY	REFERENCE	CUTTING DIAMETER	SEAT	CUTTING LENGTH	USEFUL LENGTH (max. drilling depth)	STEM CUTTING DIAMETER	SUPPORT DIAMETER (SHANK)	TOTAL LENGTH
		Øc		Lc	Lu	Øv	Øs	Lt
BEGO RS/RSX 3° ASTRA EVOLUTION 3.0° *Only for titanium and soft materials	33.325.472.01-2	1.4	25	0.4	4.7	0.5	3	50
	33.425.472.01-2	1.4	25	0.4	4.7	0.5	4	50
	33.625.472.01-2	1.4	25	0.4	4.7	0.5	6	50
STRAUMANN BONE LEVEL NP STRAUMANN BONE LEVEL RP MEDENTIS ICX TEMPLANT 4.1 STRAUMANN SYNOCTA 3.5 MEDENTIS ICX NARROW	33.315.804.01-2	1.6	15	0.7	8	0.65	3	50
	33.415.804.01-2	1.6	15	0.7	8	0.65	4	50
	33.615.804.01-2	1.6	15	0.7	8	0.65	6	50
ANTHOGYR AXIOM RG/PX XNP ANTHOGYR AXIOM RG/PX RP ANTHOGYR AXIOM RG/PX WP	33.320.704.01-2	1.6	20	0.7	7	0.8	3	50
	33.420.704.01-2	1.6	20	0.7	7	0.8	4	50
	33.620.704.01-2	1.6	20	0.7	7	0.8	6	50
ASTRA EVOLUTION 3.6 ANKYLOS ALPHABIO CONICAL STANDARD CONNECTION LASAK BIONIQ QR NEODENT GM ANKYLOS BALANCE BASE	33.330.734.01-2	1.6	30	0.7	7.3	0.8	3	50
	33.430.734.01-2	1.6	30	0.7	7.3	0.8	4	50
	33.630.734.01-2	1.6	30	0.7	7.3	0.8	6	50
NOBEL BIOCARE ACTIVE NP NOBEL BIOCARE ACTIVE 3.0 LASAK BIONIQ QN	33.335.754.01-2	1.6	35	0.7	7.5	0.65	0.5	50
	33.435.754.01-2	1.6	35	0.7	7.5	0.65	4	50
	33.635.754.01-2	1.6	35	0.7	7.5	0.65	6	50
OSSTEM TS NP CAMLOG SCREW LINE 3.8 NP CAMLOG SCREW LINE 4.3 RP KLOCKNER VEGA NV XIVE S 3.4 BIOTECH DENTAL KONTACT XNP BIOTECH DENTAL KONTACT RP DIO UF NP CAMLOG SCREW-LINE 3.3	33.345.804.01-2	1.6	45	0.7	8	0.65	3	50
	33.445.804.01-2	1.6	45	0.7	8	0.65	4	50
	33.645.804.01-2	1.6	45	0.7	8	0.65	6	50
MIS C1 NP MIS M4 NP CONELOG 3.8 CONELOG 4.3 ASTRA YELLOW ALPHABIO CONICAL HEX CONNECTION	33.360.754.01-2	1.6	60	0.7	7.5	0.65	3	50
	33.460.754.01-2	1.6	60	0.7	7.5	0.65	4	50
	33.660.754.01-2	1.6	60	0.7	7.5	0.65	6	50
BIOMET 3i CERTAIN NP ASTRA AQUA	33.390.754.01-2	1.6	90	0.7	7.5	0.65	3	50
	33.490.754.01-2	1.6	90	0.7	7.5	0.65	4	50
	33.690.754.01-2	1.6	90	0.7	7.5	0.65	6	50
ASTRA EVOLUTION 4.2	33.350.775.01-2	1.7	50	0.7	7.7	0.8	3	50
	33.450.775.01-2	1.7	50	0.7	7.7	0.8	4	50
	33.650.775.01-2	1.7	50	0.7	7.7	0.8	6	50
BIOMET 3i CERTAIN RP NOBEL BIOCARE BRANEMARK NP NOBEL BIOCARE REPLACE NP MEGAGEN ANYRIDGE RP BIOMET 3i CERTAIN WP	33.390.805.01-2	1.7	90	0.7	8	0.65	3	50
	33.490.805.01-2	1.7	90	0.7	8	0.65	4	50
	33.690.805.01-2	1.7	90	0.7	8	0.65	6	50
*BEGO S/RI 3.25-3.75 BEGO S/RI 4.1 BEGO S/RI 4.5 BEGO S/RI 5.50 STRAUMANN SCREW-RETAINED NC/RC BEGO MULTI-PLUS*	33.335.676.01-2	1.8	35	1	6.7	0.9	3	50
	33.435.676.01-2	1.8	35	1	6.7	0.9	4	50
	33.635.676.01-2	1.8	35	1	6.7	0.9	6	50
*KLOCKNER ESSENTIAL CONE 4.5 DIRECTO IMPLANTE KLOCKNER ESSENTIAL CONE 4.5 OCTACONE 12° KLOCKNER ESSENTIAL CONE 4.5 OCTACONE 25° KLOCKNER VEGA RV XIVE S 3.8 XIVE S 4.5 BIOHORIZONS 3.0 STRAUMANN SYNOCTA 6.5 STRAUMANN BLX RB STRAUMANN BLX WB STRAUMANN TLX NT STRAUMANN TLX RT STRAUMANN TLX WT DENTIUM MU SUPERLINE*	33.345.856.01-2	1.8	45	1	8.5	0.9	3	50
	33.445.856.01-2	1.8	45	1	8.5	0.9	4	50
	33.645.856.01-2	1.8	45	1	8.5	0.9	6	50

# DYNAMIC MILLING TOOL SPECIFICATIONS

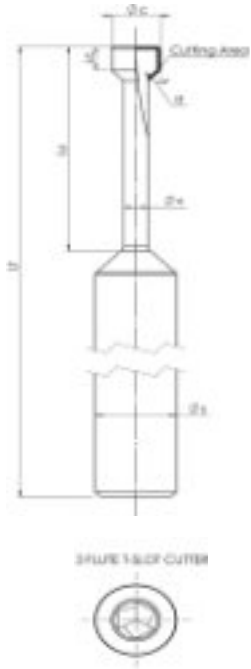

MAIN COMPATIBILITY	REFERENCE	CUTTING DIAMETER	SEAT	CUTTING LENGTH	USEFUL LENGTH (max. drilling depth)	STEM CUTTING DIAMETER	SUPPORT DIAMETER (SHANK)	TOTAL LENGTH
		Øc		Lc	Lu	Øv	Øs	Lt
"MIS C1 RP PALTOP UNIVERSAL MULTI UNIT MIS C1 WP S&M PREMIUM KHONO 3.3 S&M PREMIUM KHONO 3.8 S&M OUTLINK 3.3 S&M OUTLINK 4.1 S&M PREMIUM KHONO 4.25 BREDENT SKY NP BREDENT SKY RP ADIN TOUAREG/CLOSEFIT NP ADIN TOUAREG/CLOSEFIT UNP CAMLOG CONELOG 3.3 GLOBAL D (TEKKA) EASY IMPLANT MINI ROOT R"	33.360.756.01-2	1.8	60	1	7.5	0.9	3	50
	33.460.756.01-2	1.8	60	1	7.5	0.9	4	50
	33.660.756.01-2	1.8	60	1	7.5	0.9	6	50
"ZIMMER SCREW-VENT 3.5 ZIMMER SCREW-VENT 4.5 ASTRA EVOLUTION UNIT ABUTMENT ZIMMER TYPE 5.7 OXY FIXO	33.370.716.01-2	1.8	70	1	7.1	0.9	3	50
	33.470.716.01-2	1.8	70	1	7.1	0.9	4	50
	33.670.716.01-2	1.8	70	1	7.1	0.9	6	50
"NOBEL BIOCARE BRANEMARK RP NOBEL BIOCARE MULTI-UNIT RP BIOMET 3i OSSEOTITE NP BTI EXTERNAL CONNECTION NP BTI INTERNAL CONNECTION RP MIS MULTI-UNIT ST KEYSTONE PRIMA NP KEYSTONE PRIMA RP KEYSTONE PRIMA WP NEOSS PROACTIVE 3.4 NEOSS PROACTIVE 4.1 BIOMET 3i OSSEOTITE WP BTI EXTERNAL CONNECTION WP BTI MULTI-IM UNIVERSAL RP ANTHOGYRD MULTI-UNIT 4.8 BEGO MINI BTI INTERNAL WP LASAK MULTI-UNIT ON/OR SIC SICACE 3.3 SIC SICACE 4.2 IMPLANT DIRECT"	33.390.716.01-2	1.8	90	1	7.1	0.9	3	50
	33.490.716.01-2	1.8	90	1	7.1	0.9	4	50
	33.690.716.01-2	1.8	90	1	7.1	0.9	6	50
"STRAUMANN INTERNAL OCTAGON RP STRAUMANN INTERNAL OCTAGON 6.5"	33.315.708.01-2	1.8	15	1	7	1	3	50
	33.415.708.01-2	2	15	1	7	1	4	50
	33.615.708.01-2	2	15	1	7	1	6	50
STRAUMANN SYNOCTA RP	33.330.708.01-2	2	30	1	7	1	3	50
	33.430.708.01-2	2	30	1	7	1	4	50
	33.630.708.01-2	2	30	1	7	1	6	50
"NOBEL BIOCARE ACTIVE RP NOBEL BIOCARE ACTIVE WP"	33.335.758.01-2	2	35	1	7.5	1	3	50
	33.435.758.01-2	2	35	1	7.5	1	4	50
	33.635.758.01-2	2	35	1	7.5	1	6	50
"OSSTEM TS RP CAMLOG SCREW-LINE 5.0 CAMLOG SCREW-LINE 6.0"	33.345.808.01-2	2	45	1	8	1	3	50
	33.445.808.01-2	2	45	1	8	1	4	50
	33.645.808.01-2	2	45	1	8	1	6	50
"NOBEL BIOCARE REPLACE RP ASTRA LILAC NOBEL BIOCARE REPLACE WP ASTRA EVOLUTION 4.8 NOBEL BIOCARE BRANEMARK WP ASTRA EVOLUTION 5.4 NOBEL BIOCARE REPLACE 6.0"	33.390.958.01-2	2	90	1	9.5	1	3	50
	33.490.958.01-2	2	90	1	9.5	1	4	50
	33.690.958.01-2	2	90	1	9.5	1	6	50

## SCREWDRIVER ADAPTOR

### Screwdriver for the Dynamic Scanbody System

Ref. 43.621.410.01-2  
Screwdriver with manual handle  
Standard length: 21 mm



Ref. 43.621.415.01-2  
Tiny Screwdriver with manual handle  
Length: 21 mm



Ref. 43.624.410.01-2  
Contra-angle  
Length: 24 mm



Ref. 43.620.411.01-2  
Multi-Unit  
Contra-angle  
Length: 20 mm



## COMPLEMENTS

### Manual handle

Made of stainless steel.  
They are used to connect screwdriver bits with the contra-angle connection



### Large manual handle for laboratory

Ref. 49.601.000.03-2  
Ideal to manipulate models in the laboratory  
Length: 55.65 mm



### Manual handle for clinic

Ref. 49.601.000.01-2  
Clinic handle: used to position the prosthesis in the mouth prior to torque control in the clinic.  
Length: 15.65 mm



### Universal manual torque wrench prosthetic

Ref. 11.990.990.07-2  
Torque wrench  
4 mm square connection.  
Torque 10-35N.c



### Dynamic Screw Transfer

Ref. 49.413.000.01-2

### Manual torque wrench adapter prosthetic

Piece to connect the screwdriver with contra-angle connection to the torque wrench.



Universal Manual torque wrench adapter  
Ref. 49.604.000.05-2  
4 mm Square connection



Straumann Manual torque wrench adapter  
Ref. 49.604.000.07-2  
Straumann connection



Nobel Biocare Manual torque wrench adapter  
Ref. 49.604.000.08-2



MIS Manual torque wrench adapter  
Ref. 49.604.000.09-2

## DYNAMIC SCREWDRIVERS

Screwdriver with hexalobular head, exclusively to the 3.0 Dynamic Abutment System.  
Lengths: 18, 24, 32 mm

Hexalobular 1,70 mm. Length: 18 mm  
Ref. 43.618.201.01-2



Hexalobular 1,70 mm. Length: 24 mm  
Ref. 43.624.201.01-2



Hexalobular 1,70 mm Length: 32 mm  
Ref. 43.632.201.01-2



## DAS MU SYSTEM COMPONENTS



**Ratchet**  
49.409.000.01-2



49.409.000.02-2



**Screwdriver**  
43.321.315.01-2



43.322.315.01-2



43.321.320.01-2



**Mu ANG Insertion tool**  
49.422.000.01-2



**Healing Cap Regular**  
40.320.003.88-2



40.318.003.89-2



**Healing Cap Wide**  
40.320.003.89-2



**Impression coping**  
29.301.000.11-2 (Non-engaging\*)



**Titanium Abutment**  
35.312.209.21-2 (Non-engaging\*)  
35.322.209.21-2 (Engaging\*)



**Digital Analog**  
34.312.209.01-2



34.312.210.01-2



**Analog**  
22.612.209.01-2



**Digital Analog Positioner**  
49.309.000.01-2



**MU ScAnalog**  
23.412.209.01-2



**MU Scanbody 4.5 mm**  
53.412.209.01-2



**MU Scanbody 8 mm**  
53.422.209.02-2 (Non-engaging\*)



**MU Dynamic Scanbody**  
52.408.137.01-2



**Dynamic Scanbody Adaptor**  
50.312.209.01-2

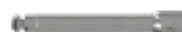

**Screwdriver Adaptor**  
43.621.410.01-2



43.624.410.01-2



**Reference Scanbody Engaging**  
54.312.210.31-2



54.312.209.31-2



**Non-engaging**  
54.322.209.31-2



**MU Dynamic TiBase**  
31.322.209.01-2 (Non-engaging\*)  
31.312.209.01-2 (Engaging\*)



**MU Dynamic 3TiBase**  
31.322.209.21-2 (Non-engaging\*)

COMPONENTS OPTIONS: \* Non-engaging - # Engaging - n#

## DAS MU SYSTEM COMPONENTS



### MU Dynamic TiBase

Type A Engaging  
31.312.210.01-2



Type B Engaging  
31.313.210.01-2



Non-engaging  
31.322.210.01-2



### Peek Pins

TYPE A  
49.414.000.01-2 (6 mm)  
49.415.000.01-2 (9 mm)  
49.416.000.01-2 (13 mm)



TYPE B  
49.414.000.02-2 (6 mm)  
49.415.000.02-2 (9 mm)  
49.416.000.02-2 (13 mm)



TYPE C  
49.414.000.03-2 (6 mm)  
49.415.000.03-2 (9 mm)  
49.416.000.03-2 (13 mm)



TYPE D  
49.416.000.04-2 (13 mm)



TYPE E  
49.416.000.05-2 (13 mm)



### CAPS

Regular  
49.418.000.01-2 (3,8 mm)  
49.419.000.01-2 (6 mm)  
49.420.000.01-2 (8 mm)



Wide  
49.418.000.02-2 (3,8 mm)  
49.419.000.02-2 (6 mm)  
49.420.000.02-2 (8 mm)



### Dynamic Screw

41.320.040.01-2



41.318.050.01-2



### Provisional (temporary) Dynamic Screw

41.320.050.02-2



41.318.057.01-2



### Straight Screw

40.320.003.06-2



### Dynamic Screwdriver

43.618.201.01-2 (18 mm)  
43.624.201.01-2 (24 mm)  
43.632.201.01-2 (32 mm)



### Screwdriver Hex.1,2

43.601.103.02-2



### MU DMTone

33.390.716.01-2 Shank Ø3  
33.490.716.01-2 Shank Ø4  
33.690.716.01-2 Shank Ø6

COMPONENTS OPTIONS: <sup>•</sup> Non-engaging - R <sup>•</sup> Engaging - NR

## TERMS AND CONDITIONS

These guarantee terms and conditions ("T&C") cover the entire range of Talladium products ("Products"), manufactured by TALLADIUM ESPAÑA S.L. and distributed by Geoda Medical S.L. or official dealers. The guarantee described in these T&C is exclusively in benefit of the clinician ("Clinician") and of the dental technician ("Technician") and not for the benefit of third parties or institutions, including patients.

## GUARANTEE PERIOD

TALLADIUM ESPAÑA S.L. offers a lifelong guarantee for its entire range of products starting from the date of issue of the invoice.

## GUARANTEE SCOPE

Subject to the limitations and exceptions described in these T&C, TALLADIUM ESPAÑA S.L. will offer the following benefits:

**QUALITY:** If there are defects in the materials or in the manufacturing of the Product, TALLADIUM ESPAÑA S.L. will replace the Product with no additional cost.

**SAFETY:** If, having complied with all the product indications, the prosthesis should have to be made again, due to a fault in the Dynamic Abutment or Dynamic Titanium Base system, TALLADIUM ESPAÑA S.L. will replace the abutments and screws necessary to remake the prosthesis, as well as the costs derived from its manufacturing.

In case of having used our products and having complied with all the product indications, the implants suffer any damage, TALLADIUM ESPAÑA S.L. will pay the cost of the implants. This coverage will only be valid during the first 6 months after the collocation of the prosthesis which includes our products.

## CLAIM REQUIREMENTS AND PROCEDURE

To receive the benefits indicated in these T&C, the treating Clinician must satisfy the following requirements:

- The claim must be notified to TALLADIUM ESPAÑA S.L. within (30) days since the date the claimed defect was detected.
- This requires that the Clinician or Technician must contact the customer service department by telephone or by e-mail to make the claim.
- A claim form will be completed, which, together with a document or report which justifies the faulty Product and the faulty Product itself, will be sent by the customer to TALLADIUM ESPAÑA S.L. offices, within the previously indicated period.
- Clinicians or Technicians presenting a claim in agreement with these T&C must be up to date in any payments owing to TALLADIUM ESPAÑA S.L. or to any of its subsidiaries, at the time when the claim form is presented.
- All the use procedures of our Products must be carried out in agreement with the instructions of TALLADIUM ESPAÑA S.L. as well as in accordance with commonly accepted dentistry practices.
- The expenses derived from this procedure will be assumed by the customer. The return shipping costs will be assumed by TALLADIUM ESPAÑA S.L. in all those cases covered by these T&C.

Regardless of the guarantee rights, claims should be notified as soon as possible in order to comply with regulatory requirements.

## GENERAL LIMITATIONS OF THIS GUARANTEE

With the exception of the guarantee described in these T&C, neither TALLADIUM ESPAÑA S.L. nor its representatives, nor third parties manufacturing or distributing the Products, represent or offer a guarantee, agreement or any other express or implicit, oral or written, commitment, with respect to the Products (without limitation), including guarantees involved in the marketing, durability or suitability for individual uses or purposes. In addition and within the maximum extent permitted by the relative law, TALLADIUM ESPAÑA S.L. rejects (on its own behalf, and on behalf of its representatives and third parties that manufacture or distribute Products) any responsibility with respect to any direct or indirect damage caused, which may result from or be a consequence of the design, composition of the dental prosthesis into which the Products are integrated.

## GUARANTEE EXCLUSIONS

TALLADIUM ESPAÑA S.L. limits this guarantee to:

- Transformed abutments that form part of the dental prosthesis. But not the screws used to anchor them.
- Those products that are not used with the accessories and parts marketed by Talladium España

## AMENDMENT OR SUSPENSION OF THE GUARANTEE

TALLADIUM ESPAÑA S.L. reserves the right to amend or withdraw these T&C at any time and without prior notification. Any modification or suspension shall not affect products already placed in patients.

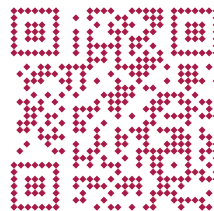

This printed version is probably outdated and may not include all products or compatibilities.

**Scan and download the latest version of this catalogue**

[www.dynamicabutment.com](http://www.dynamicabutment.com)

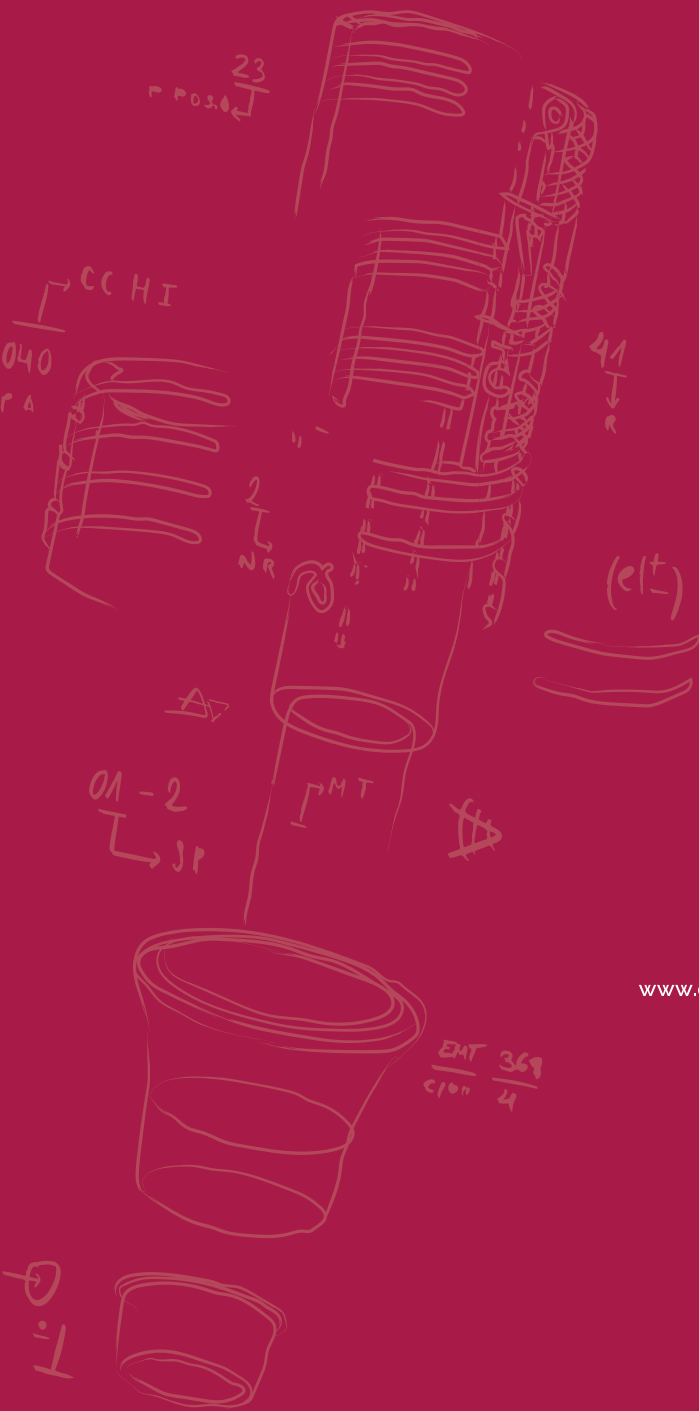

[www.dynamicabutment.com](http://www.dynamicabutment.com)

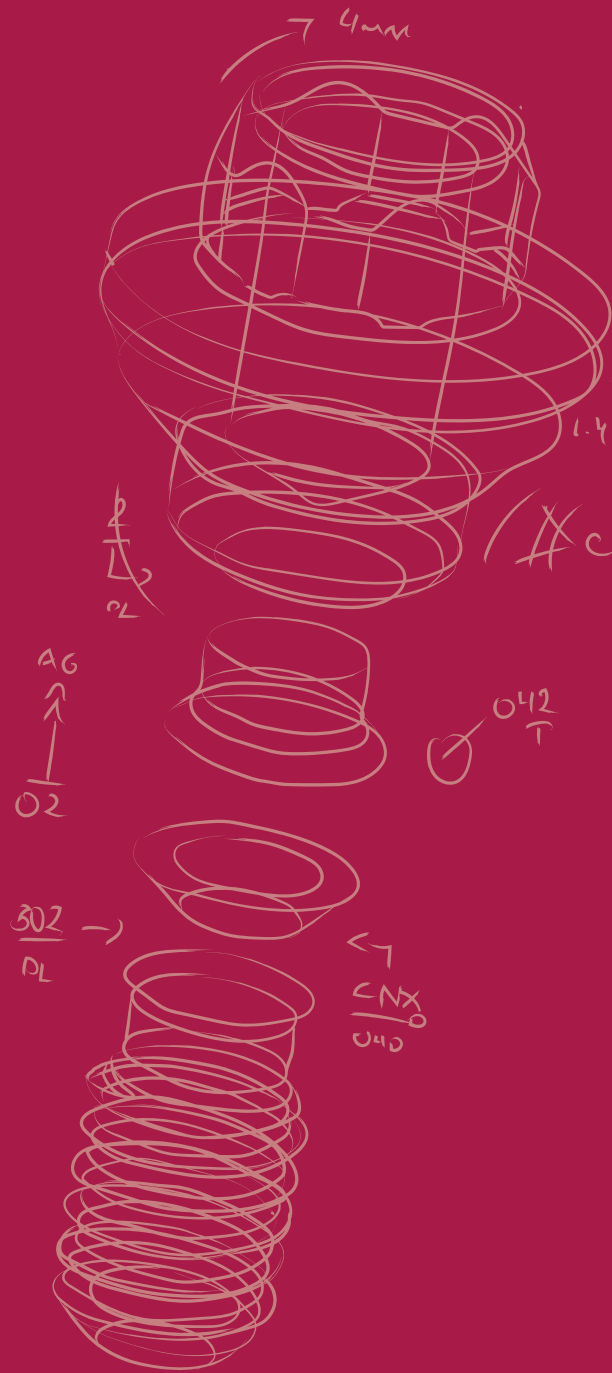

Virginia Woolf, 17  
25005 · Lleida (Spain)

INTERNATIONAL +34 873 450 709  
[das@dynamicabutment.com](mailto:das@dynamicabutment.com)

SPAIN +34 973 289 580  
[spain@dynamicabutment.com](mailto:spain@dynamicabutment.com)